

### General Description

SY6813 and SY6813A are ultra-low  $R_{DS(ON)}$  load switch with reverse current blocking function. The controlled ramp up speed avoids the inrush current during turn on. The device works under a wide input voltage range from 1.2V to 5.5V.

### Ordering Information

SY6813  (    )  
 Temperature Code  
 Package Code  
 Optional Spec Code

Ordering Number	Package type	Note
SY6813PEC	6 ball CSP	----
SY6813APEC	6 ball CSP	----

### Features

- 1.2V to 5.5V Input Voltage Range
- Low  $R_{DS(ON)}$  for Internal Pass Switch: 22m $\Omega$  at  $V_{IN}=5V$
- 3A Continuous Load Current Capability
- Reverse Blocking (No Body Diode)
- ON/OFF Control Input
- Controlled Turn On Slew Rate
- Auto Output Capacitor Discharge Function:
  - ✧ SY6813: Auto Output Capacitor Discharge Function
  - ✧ SY6813A: No Output Capacitor Discharge Function
- RoHS Compliant and Halogen Free
- Ultra Small CSP-6 Package 1.0mm $\times$ 1.5mm, 0.5mm pitch, 0.5mm height

### Applications

- Smart Phone
- MID
- E-Book
- Storage, DSLR, and Portable Device

### Typical Applications

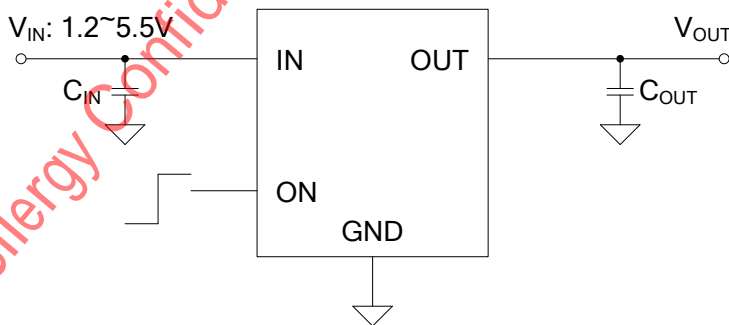

Figure 1. Schematic Diagram

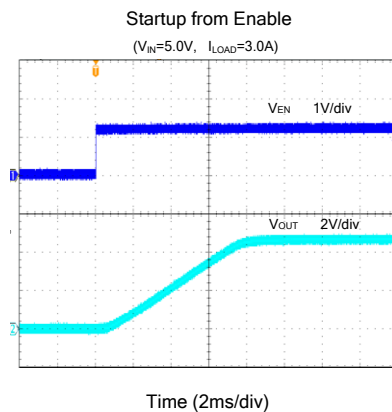
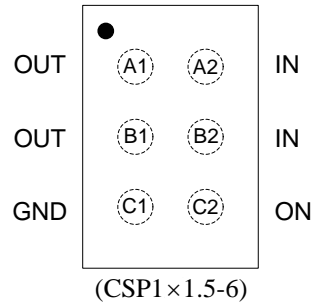

Figure 2. Startup Figure

## Pinout (Top view)



**Top Mark: THxyz for SY6813** (Device code: TH, *x=year code, y=week code, z=lot number code*)

**WVxyz for SY6813A** (Device code: WV, *x=year code, y=week code, z=lot number code*)

Pin Name	Pin Number	Pin Description
IN	A2,B2	Input pin.
OUT	A1,B1	Output pin.
GND	C1	Ground pin.
ON	C2	ON/OFF control. Active high. Do not leave it floating.

## Absolute Maximum Ratings (Note 1)

All Pins	6V
Power Dissipation, $P_D$ @ $T_A = 25^\circ\text{C}$	1.0W
Package Thermal Resistance (Note 2)	
$\theta_{JA}$	123°C/W
$\theta_{JC}$	17°C/W
Junction Temperature Range	150°C
Lead Temperature (Soldering, 10 sec.)	260°C
Storage Temperature Range	-65°C to 150°C
ESD Susceptibility	
HBM (Human Body Mode)	8kV
CDM (Charged Device Mode)	1.5kV

## Recommended Operating Conditions (Note 3)

IN, OUT	1.2V to 5.5V
EN	-0.3V to $V_{IN}+0.3V$
Junction Temperature Range	-40°C to 125°C
Ambient Temperature Range	-40°C to 85°C



## Electrical Characteristics

( $V_{IN} = 5.0V$ ,  $T_A = 25^\circ C$  unless otherwise specified)

Parameter	Symbol	Test Conditions	Min	Typ	Max	Unit
Input Voltage Range	$V_{IN}$		1.2		5.5	V
Shutdown Current	$I_{SHDN2}$	ON=Low, $V_{OUT}=GND$			1	$\mu A$
Quiescent Current	$I_Q$	$I_{OUT}=0$		4	8	$\mu A$
FET $R_{ON}$	$R_{DS(ON)}$			22	30	$m\Omega$
ON Input Logic High	$V_{IH}$		1			V
ON Input Logic Low	$V_{IL}$				0.4	V
Turn On Rise Time	$t_{RISE}$	$C_{OUT}=1\mu F$ , Open Load	3	6	9	ms
Output Discharge Resistor	$R_{DSC}$		35	50	70	$\Omega$

**Note 1:** Stresses beyond the “Absolute Maximum Ratings” may cause permanent damage to the device. These are stress ratings only. Functional operation of the device at these or any other conditions beyond those indicated in the operational sections of the specification is not implied. Exposure to absolute maximum rating conditions for extended periods may affect device reliability.

**Note 2:**  $\theta_{JA}$  is measured in the natural convection at  $T_A = 25^\circ C$  on a low effective single layer thermal conductivity test board of JEDEC 51-3 thermal measurement standard.

**Note 3:** The device is not guaranteed to function outside its operating conditions

Block Diagram

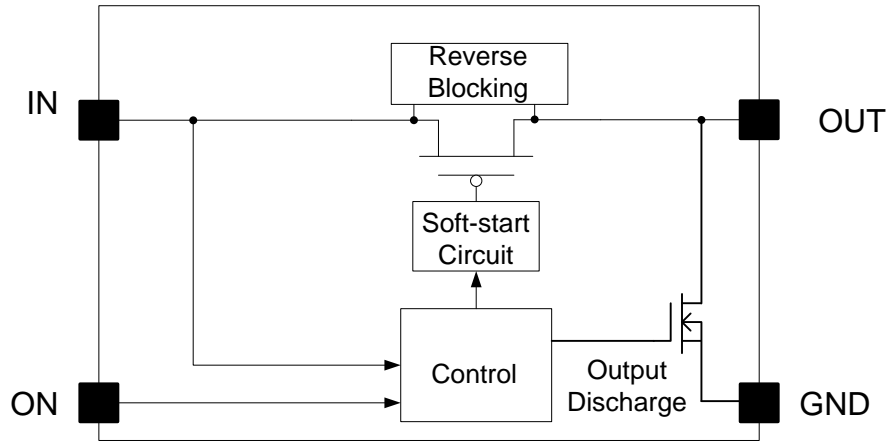

(SY6813)

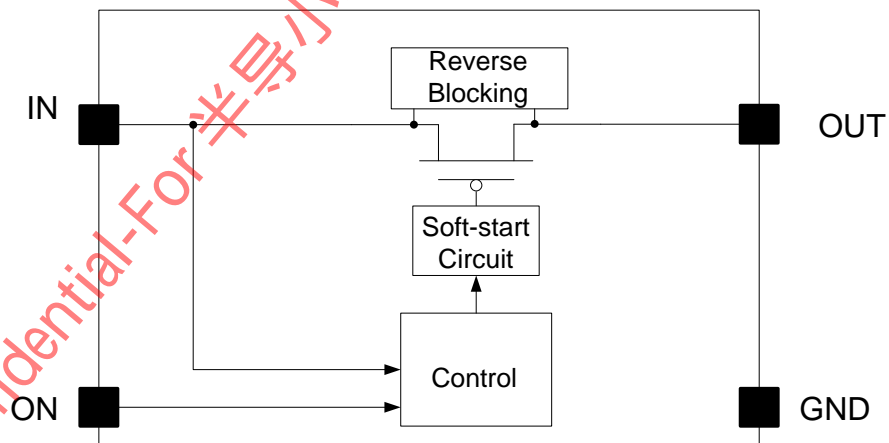

(SY6813A)

Silergy Confidential-For 半导体芯

**CSP1.0×1.5-6 Outline Drawing**

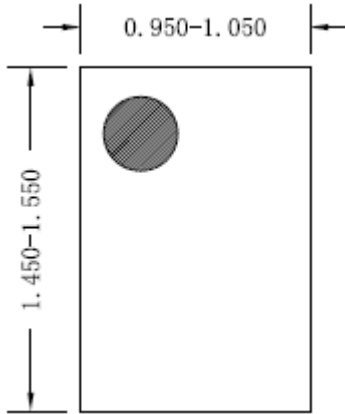

**Top View**

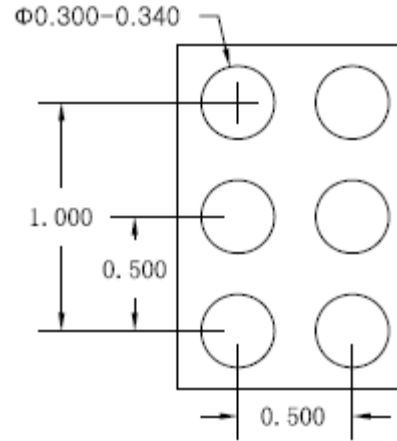

**Bottom View**

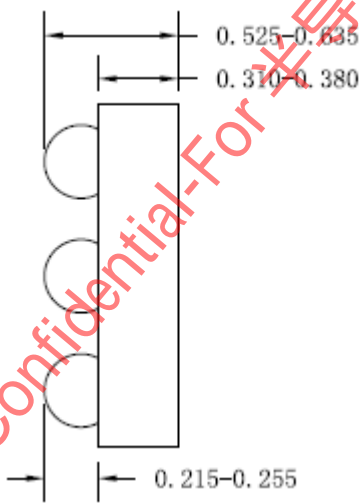

**Side View**

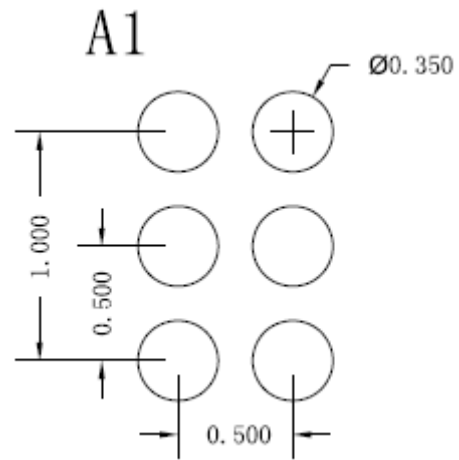

**Recommended PCB layout  
(Reference Only)**

**Notes: All dimension in millimeter and exclude mold flash & metal burr**

**Taping & Reel Specification**

**1. CSP1.0×1.5 taping orientation**

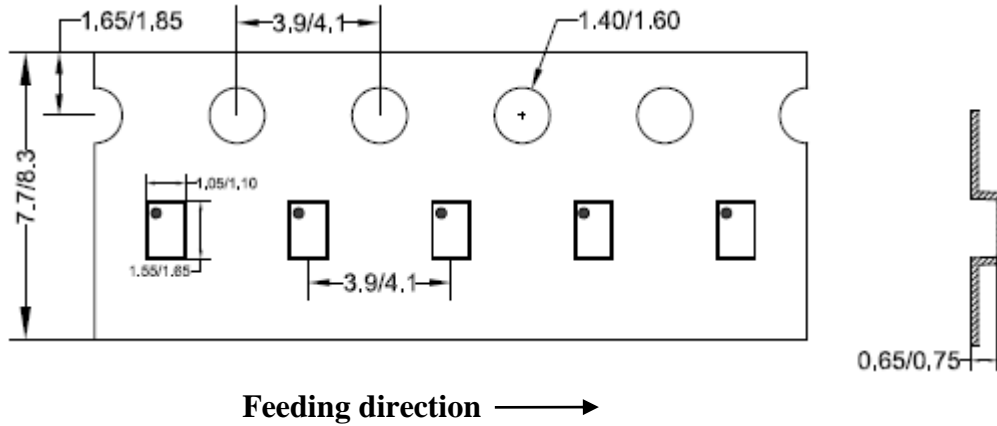

**2. Carrier Tape & Reel specification for packages**

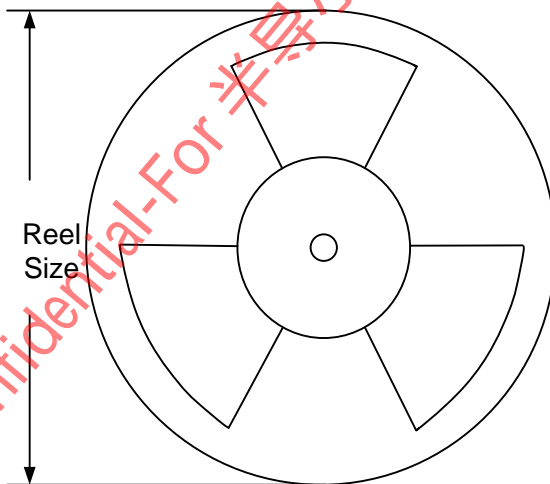

Package types	Tape width (mm)	Pocket pitch(mm)	Reel size (Inch)	Trailer length(mm)	Leader length (mm)	Qty per reel
CSP1.5×1.0	8	4	7"	400	400	3000

**3. Others: NA**