

General Description

The SY6881 is a programmable over voltage protection switch with high current capability to prevent damage to the downstream system with low voltage rating. It achieves wide input voltage range from DC 2.5V to DC 28V. Extremely low power path resistance R_{PWPT} helps to reduce power loss during the normal operation. An open drain indicator pin is opened to show the operation status of device. It integrates the over-temperature protection shutdown and auto-recovery with hysteresis to protect against over current events. This IC along with small CSP (1.32mm×1.86mm) footprint provides small PCB area application.

Ordering Information

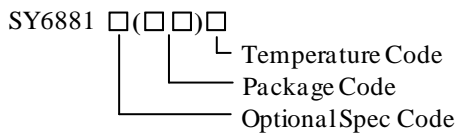

Ordering Number	Package Type	Note
SY6881PTC	CSP1.32×1.86-12	

Features

- Surge Protection IEC 61000-4-5 to +100V
- Extremely Low Power Path Resistance R_{PWPT}
 - $R_{PWPT}=32m\Omega$ typ.
- Programmable Over Voltage Threshold from +3.6V to +22V
- Default Over Voltage Threshold 6.8V
- Open Drain Indicator Pin for Operation Status
- Internal Soft-start to Prevent In-rush Current
- Thermal Shutdown Protection & Auto Recovery
- IEC61000-4-2 Air Discharge > 15KV
- IEC61000-4-2 Contact Discharge > 8KV
- RoHS Compliant and Halogen Free
- Compact Package: CSP 1.32mm×1.86mm

Applications

- Smart Phone
- Tablet PCs
- Mobile Device

Typical Application

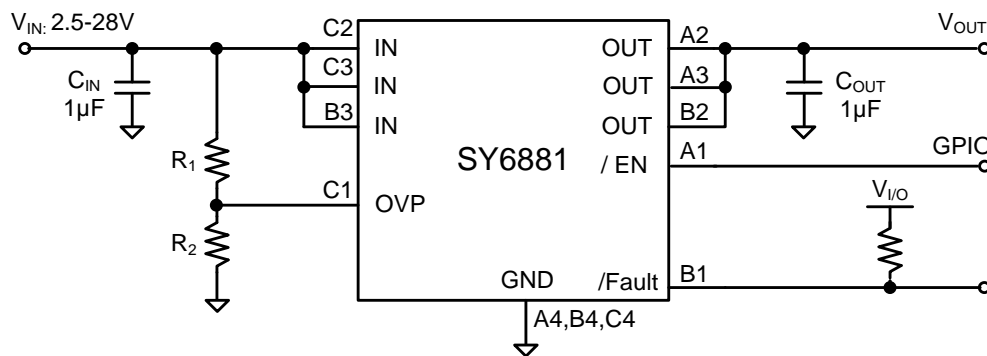
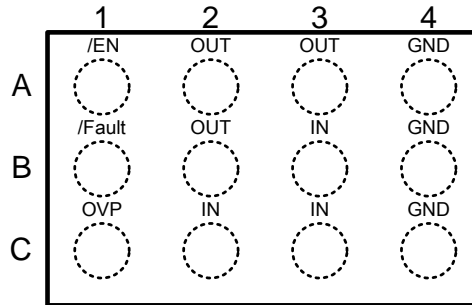

Figure1. Schematic Diagram

Pinout (top view)



(CSP1.32x1.86-12)

Top Mark: Ntxyz, (Device code: Nt; x=year code, y=week code, z= lot number code)

Pin Name	Pin Number	Pin Description
IN	B3, C2, C3	Power input pin. Connect the IN pin together. Decouple high frequency noise by connecting at least a 0.1 μ F MLCC to ground.
OUT	A2, A3, B2	Output voltage pin. Source side of the internal FET. Connect the OUT pins together for normal operation.
OVP	C1	External OVP program pin. Connect resistor divider to this pin to program the OVP threshold. Make sure V_{OVP} is higher than the External OVP select threshold; otherwise, the internal default OVP threshold is active. Pull down this pin to ground to disable external program function.
/Fault	B1	Open drain indicator pin. /Fault is pulled low when over voltage, thermal shutdown protection or other fault condition occurs. Otherwise, /Fault pin is high impedance.
GND	A4, B4, C4	Power ground pin.
/EN	A1	Pull low to enable SY6881. Do not leave it floating.

Block Diagram

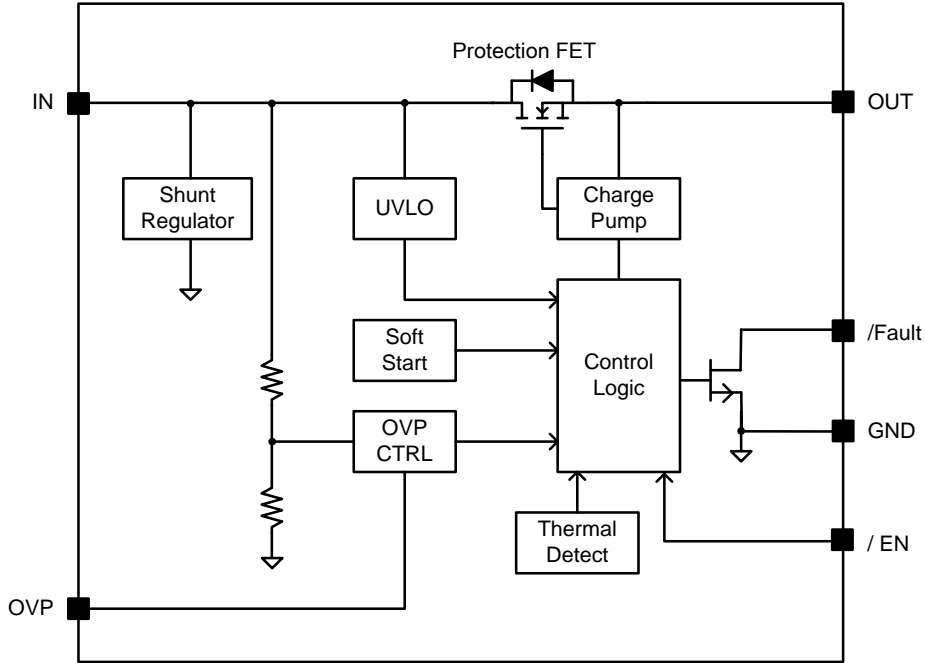

Figure2. Block Diagram

Absolute Maximum Ratings (Note 1)

IN, OVP	-----	29V
OUT	-----	IN + 0.3V
/Fault, /EN	-----	-29V
Continues IN, OUT Current	-----	5A
Peak IN, OUT Current (10ms),	-----	8A
Max Power Dissipation Under T _A =25°C	-----	2.4W
Package Thermal Resistance (Note 2)		
θ _{JA}	-----	51.15°C/W
θ _{IC}	-----	6.82°C/W
Junction Temperature Range	-----	150°C
Lead Temperature (Soldering, 10 sec.)	-----	260°C
Storage Temperature Range	-----	-65°C to 150°C

Recommended Operating Conditions (Note 3)

IN	-----	2.5V to 28V
Junction Temperature Range	-----	-40°C to 125°C
Ambient Temperature Range	-----	-40°C to 85°C

Electrical Characteristics

($V_{IN} = 2.5V$ to $28V$, $C_{IN}=1\mu F$, $C_{OUT}=1\mu F$, $T_A = 25^\circ C$, unless otherwise specified)

Parameter	Symbol	Test Conditions	Min	Typ	Max	Unit
Shutdown Input Current	I_{SD}	$V_{IN}=5V$, $/EN=5V$, $V_{OVP}=0V$		3		μA
Input Voltage Range	V_{IN}		2.5		28	V
Input UVLO Threshold	V_{UVLO}				2.4	V
UVLO Hysteresis	V_{HYS}			0.1		V
Input Clamp Voltage	V_{INCLP}	$I_{IN}=10mA$		33		V
Bias Current	I_{BIAS}	$V_{IN}=5V$			100	μA
OVP Current	I_{OVP}	$V_{OVP}=3V$, $V_{IN}=5V$, $V_{OUT}=0V$			100	μA
Internal Default OVP Threshold	V_{OVDP}	Rising	6.5	6.75	7.0	V
		Falling	6.4			V
OVP Program Threshold	V_{OVPPPT}		1.22	1.26	1.30	V
External OVP Select Threshold	V_{OVP_SELECT}			0.3	0.35	V
$/EN$ High Threshold	V_{ENH}		1.2			V
$/EN$ Low Threshold	V_{ENL}				0.4	V
Programmable OVP Range	V_{OVPPR}		3.6		22	V
Resistance of Power Path	R_{PWPT}	$V_{IN}=5V$, $I_{OUT}=200mA$, from IN to OUT		32	39	$m\Omega$
Output Load Capacitance	C_{OUT}	$V_{IN}=5V$			1000	μF
$/Fault$ Low Voltage	V_{FAL}	$V_{IN}=5V$, $I_{SINK}=1mA$			0.4	V
$/Fault$ Leakage Current	I_{FAL}	$V_{IN}=5V$, $V_{FAL}=3.3V$, $/Fault$ high impedance			1	μA
Deglintch Time	t_{DG}	$V_{IN}=5V$, time from $2.5V < V_{IN} < V_{OVP}$ to $V_{OUT}=10\%$ of V_{IN}		12		ms
Switch Turn On Time	t_{ON}	$V_{IN}=5V$, $R_L=100$, $C_{OUT}=100\mu F$; $V_{OUT}=10\%$ of V_{IN} to 90% V_{IN}		1.3		ms
Switch Turn Off Time (Note 4)	t_{OFF}	$V_{OVP}>1.2V$ to V_{OUT} stop rising		0.1		μs
Thermal Shutdown Temperature	T_{SD}			150		$^\circ C$
Thermal Shutdown Hysteresis	T_{HYS}			20		$^\circ C$

Note 1: Stresses beyond the “Absolute Maximum Ratings” may cause permanent damage to the device. These are stress ratings only. Functional operation of the device at these or any other conditions beyond those indicated in the operational sections of the specification is not implied. Exposure to absolute maximum rating conditions for extended periods may affect device reliability.

Note 2: θ_{JA} is measured in the natural convection at $T_A = 25^\circ C$ on Silergy test board.

Note 3: The device is not guaranteed to function outside its operating conditions.

Note 4: Guaranteed by design but not production tested.

CSP1.32×1.86-12 Package Outline Drawing

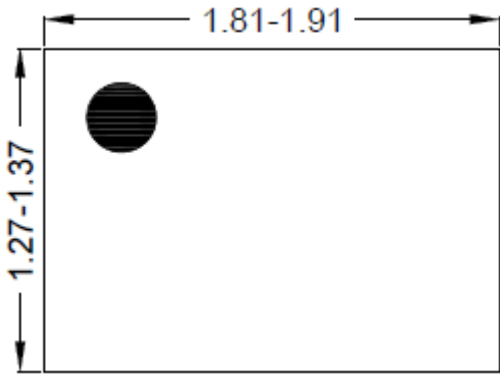

Top view

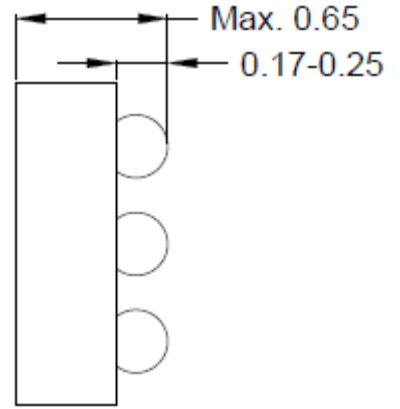

Side view

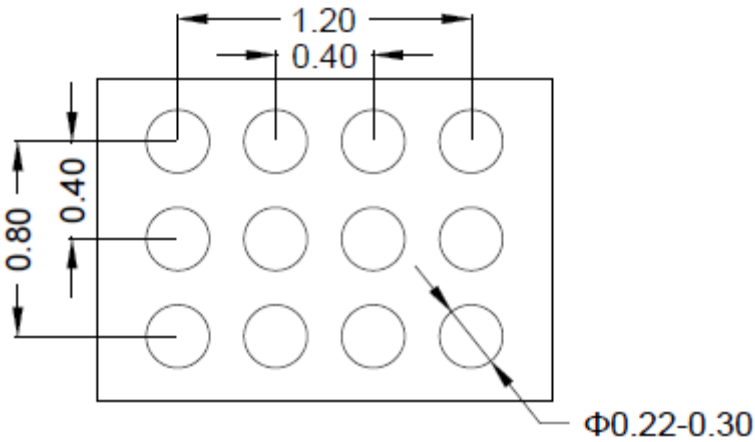

Bottom view

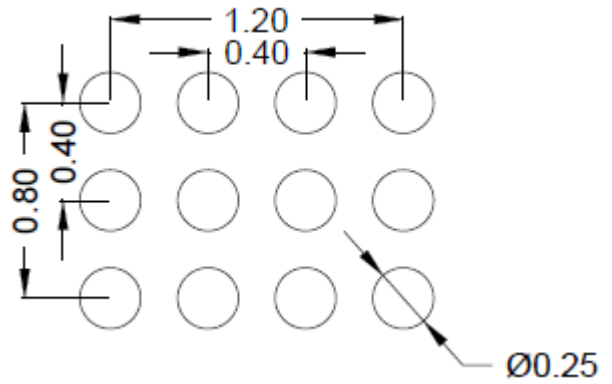

**Recommended PCB layout
(Reference only)**

Notes: All dimension in millimeter and exclude mold flash & metal burr.

Taping & Reel Specification

1. Taping orientation

CSP1.32×1.86

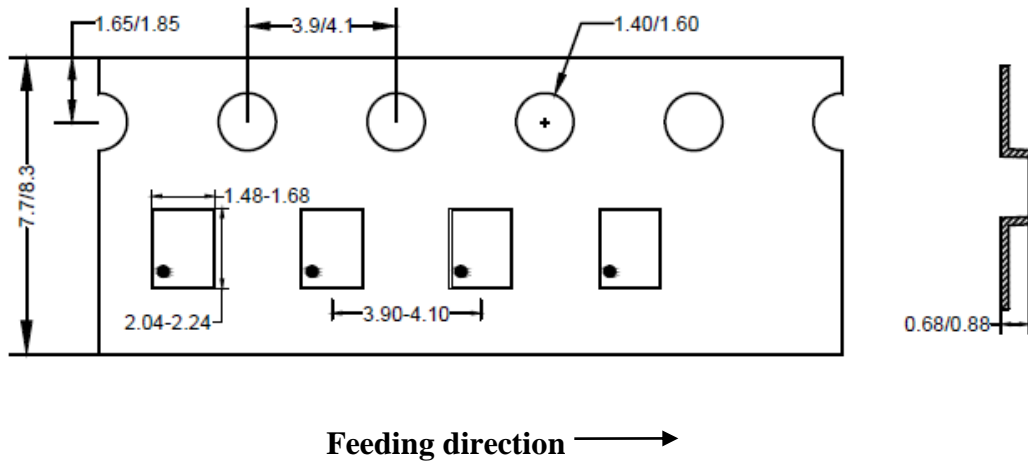

2. Carrier Tape & Reel specification for packages

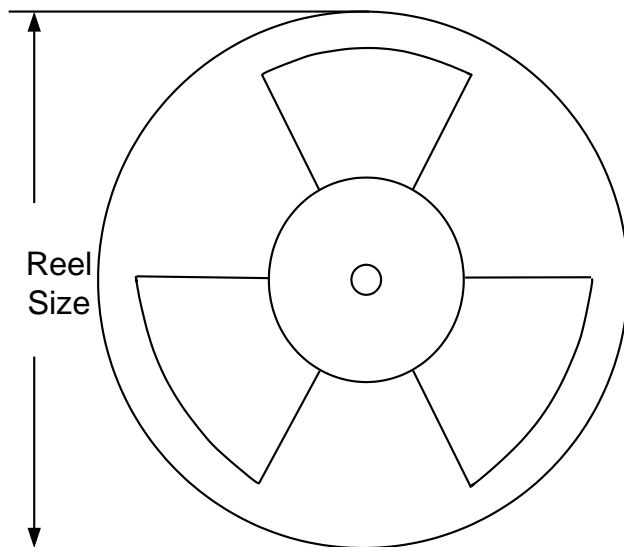

Package types	Tape width (mm)	Pocket pitch(mm)	Reel size (Inch)	Trailer length(mm)	Leader length (mm)	Qty per reel
CSP1.32×1.86	8	4	7"	400	160	3000

3. Others: NA