



Application Note: AN_SY8705

High Efficiency, 1MHz, 3A, 30V Step Down White LED Driver

General Description

SY8705 is a high efficiency step down regulator capable of driving 3A white LED from up to 30V input. It integrates the low R_{ON} MOSFET and internal compensation. The 1MHz switching frequency allows the use of very small inductor.

Ordering Information

SY8705 □(□□)□
 □ Temperature Code
 □ Package Code
 □ Optional Spec Code

Ordering Number	Package type	Note
SY8705FCC	SO8E	3A

Features

- Wide input range: 2.5-30 V
- 1 MHz switching frequency
- Very low R_{ON} : 100mΩ
- Enable and dimming control available
- 20kHz~1MHz wide dimming frequency range
- Compact package: SO8E
- RoHS Compliant and Halogen Free

Applications

- Flash light
- Display cabinet lamp
- LED sign

Typical Applications

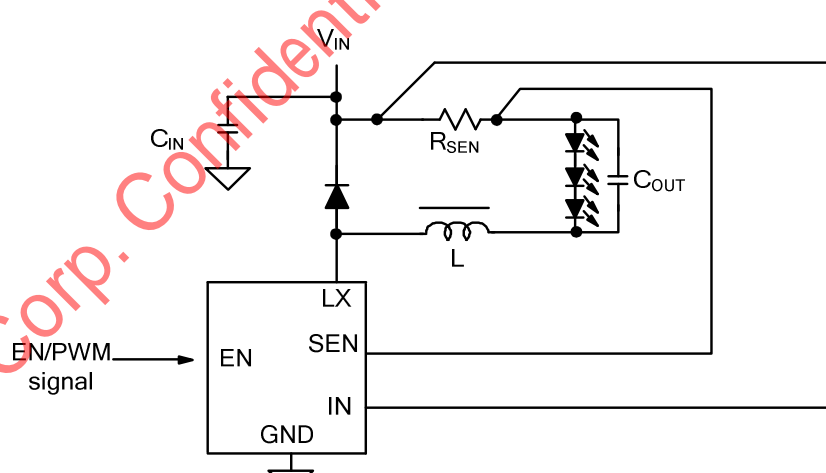
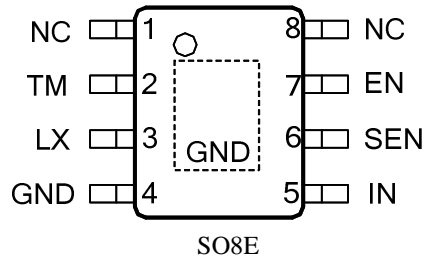

Figure 1. Schematic diagram

Pinout (top view)

Top Mark: AKUxyz for SY8705FCC (device code: AKU, x=year code, y=week code, z=lot number code)

Pin Name	SO8E	Pin Description
IN	5	Input pin. Decouple this pin to GND pin with 1uF ceramic cap. Also used as the positive current sense pin.
SEN	6	Negative Current Sense Pin.
GND	4	Ground pin
LX	3	Inductor node.
EN	7	Enable and dimming control. Pull high to turn on IC. The recommend dimming frequency range is 20kHz~1MHz.
TM	2	Test mode pin. Ground this pin in the real application.

Absolute Maximum Ratings (Note 1)

LX, IN	33V
SEN	$V_{IN} \pm 0.7V$
All other pins	4V
Power Dissipation, PD @ TA = 25°C SO8E	3.3W
Package Thermal Resistance (Note 2)	
θ_{JA}	30°C/W
θ_{JC}	10°C/W
Junction Temperature Range	125°C
Lead Temperature (Soldering, 10.sec.)	260°C
Storage Temperature Range	-65°C to 150°C

Recommended Operating Conditions (Note 3)

IN, LX, EN	2.5V to 30V
SEN	$V_{IN} \pm 0.5V$
All other pins	0-3.6V
Junction Temperature Range	-40°C to 125°C
Ambient Temperature Range	-40°C to 85°C

Electrical Characteristics

($V_{IN} = 5V$, $I_{OUT} = 100mA$, $T_A = 25^\circ C$ unless otherwise specified)

Parameter	Symbol	Test Conditions	Min	Typ	Max	Unit
Input Voltage Range	V_{IN}		2.5		30	V
Shutdown Current	I_{SHDN}	EN=0		5	10	μA
Low Side Main FET R_{ON}	$R_{DS(ON)l}$			100		m Ω
Main FET Current Limit	I_{LIM1}		4			A
Switching Frequency	F_{SW}		0.8	1	1.2	MHz
Current Sense Limit	V_{IN-SEN}		96	100	104	mV
EN Rising Threshold	V_{ENH}		1.5			V
EN Falling Threshold	V_{ENL}				0.4	V
IN UVLO Rising Threshold	$V_{IN,UVLO}$				2.5	V
UVLO Hysteresis	$V_{UVLO,HYS}$			0.1		V
Thermal Shutdown Temperature	T_{SD}			150		C
Max Duty Cycle				90		%
Min Duty Cycle				10		%

Note 1: Stresses listed beyond “Absolute Maximum Ratings” may cause permanent damage to the device. These are for stress ratings. Functional operation of the device at these or any other conditions beyond those indicated in the operational sections of the specifications is not implied. Exposure to absolute maximum rating conditions may remain possibility to affect device reliability.

Note 2: θ_{JA} is measured in the natural convection at $T_A = 25^\circ C$ on a low effective single layer thermal conductivity test board of JEDEC 51-3 thermal measurement standard.

Note 3. The device is not guaranteed to function outside its operating conditions

Block Diagram

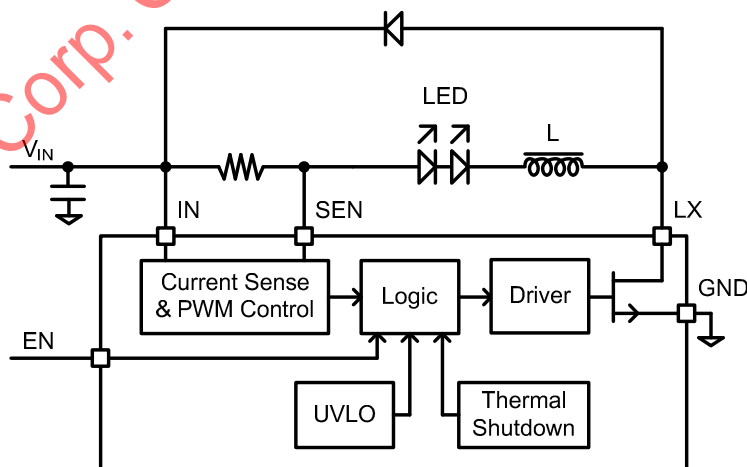

Typical Operation Characteristics

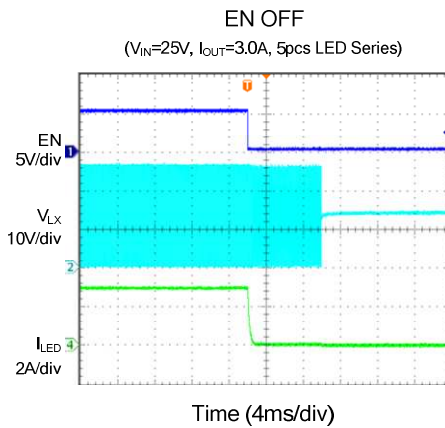
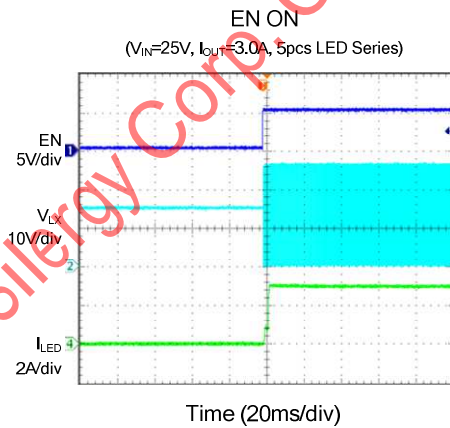
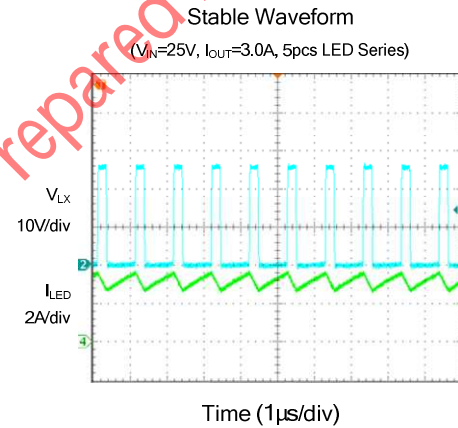
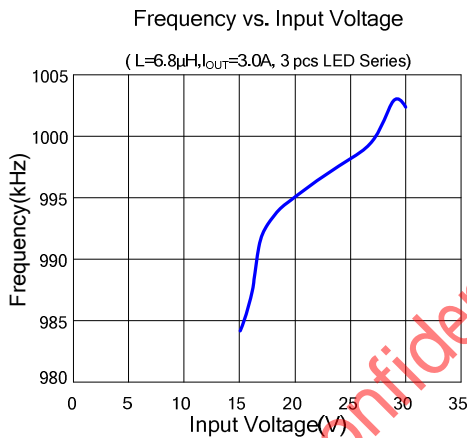
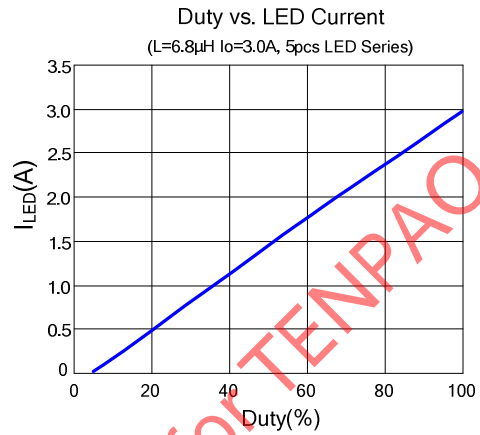
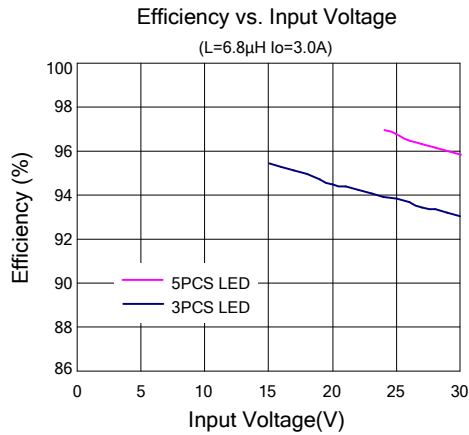

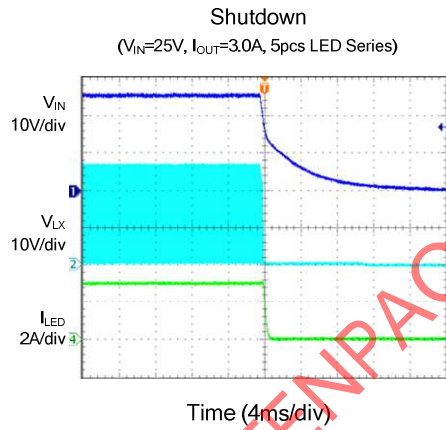
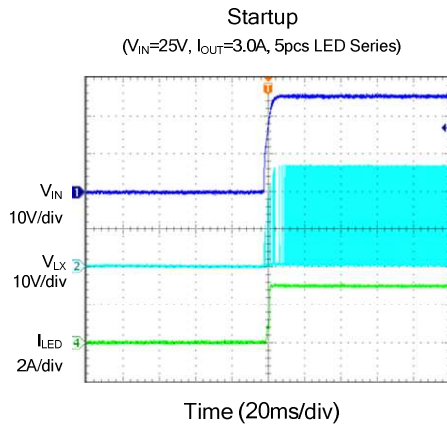

Silergy Corp. Confidential-Prepared for TENPAO

Operation

SY8705 is a floating buck regulator IC that integrates the PWM control, power MOSFET on the same die to minimize the switching transition loss and conduction loss. With ultra low $R_{DS(ON)}$ power switches and proprietary PWM control, this regulator IC can achieve the high efficiency and the high switch frequency simultaneously to minimize the external inductor and capacitor size, and thus achieving the minimum solution footprint.

Applications Information

Because of the high integration in the IC, the application circuit based on this IC is rather simple. Only input capacitor C_{IN} , output capacitor C_{OUT} , output inductor L and current sense resistor R_{SEN} need to be selected for the targeted applications specifications.

Current sense resistor R_{SEN} :

Choose R_{SEN} to program the proper output Current:

$$I_{LED}(A) = \frac{0.1(V)}{R_{SEN}(\Omega)}$$

Input capacitor C_{IN} :

The ripple current through input capacitor is calculated as:

$$I_{CIN_RMS} = I_{OUT} \cdot \sqrt{D(1-D)}$$

A typical X7R or better grade ceramic capacitor with suitable capacitance should be chosen to handle this ripple current well. To minimize the potential noise problem, place this ceramic capacitor really close to the IN and GND pins. Care should be taken to minimize the loop area formed by C_{IN} and IN/GND pins.

Output capacitor C_{OUT} :

The output capacitor is selected to handle the output current ripple noise requirements. For the best performance, it is recommended to use X7R or better grade ceramic capacitor greater than 1uF capacitance.

Output inductor L :

There are several considerations in choosing this inductor.

- 1) Choose the inductance to provide the desired ripple current. It is suggested to choose the ripple current to be about 40% of the maximum output current. The inductance is calculated as:

$$L = \frac{V_{OUT}(1 - V_{OUT}/V_{IN,MAX})}{F_{SW} \times I_{OUT,MAX} \times 40\%}$$

where F_{SW} is the switching frequency and $I_{OUT,MAX}$ is the LED current.

The SY8705 regulator IC is quite tolerant of different ripple current amplitude. Consequently, the final choice of inductance can be slightly off the calculation value without significantly impacting the performance.

- 2) The saturation current rating of the inductor must be selected to be greater than the peak inductor current under full load conditions.

$$I_{SAT, MIN} > I_{OUT, MAX} + \frac{V_{OUT}(1 - V_{OUT}/V_{IN,MAX})}{2 \cdot F_{SW} \cdot L}$$

Layout Design:

The layout design of SY8705 regulator is relatively simple. For the best efficiency and minimum noise problems, we should place the following components close to the IC: C_{IN} , L , C_{OUT} and R_{SEN} .

- 1) It is desirable to maximize the PCB copper area connecting to GND pin to achieve the best thermal and noise performance. If the board space allowed, a ground plane is highly desirable.
- 2) C_{IN} must be close to Pins IN and GND. The loop area formed by C_{IN} and GND must be minimized.
- 3) The PCB copper area associated with LX pin must be minimized to avoid the potential noise problem.

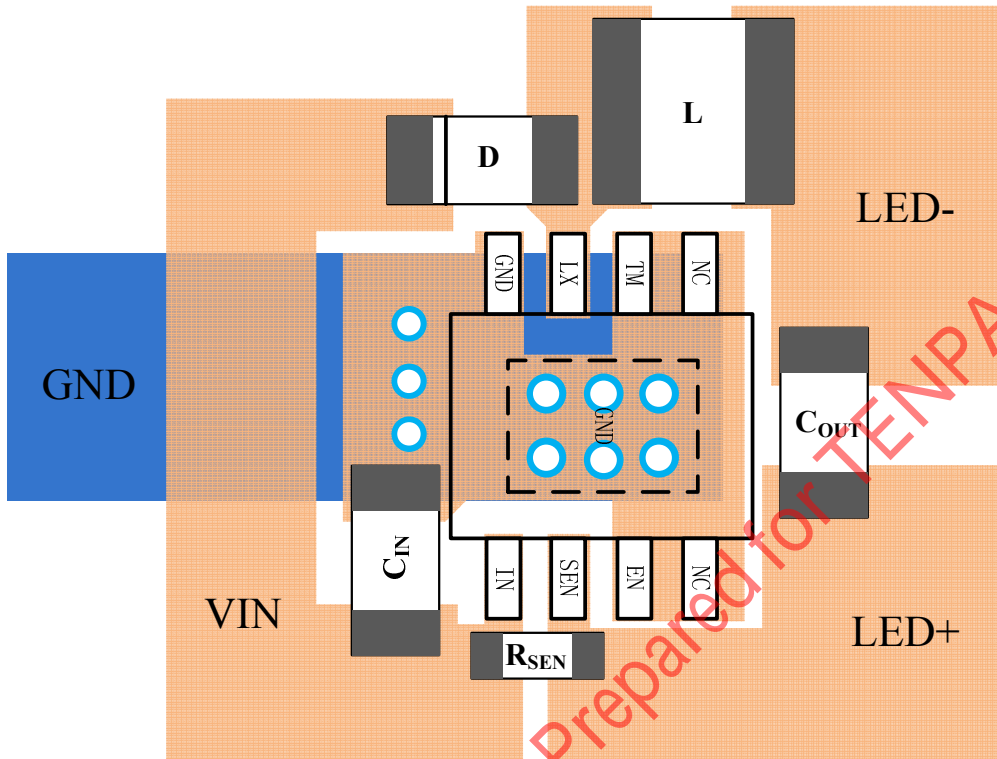

Silergy Corp. Confidential-Prepared for TENPAO

SO8E Package outline & PCB layout design

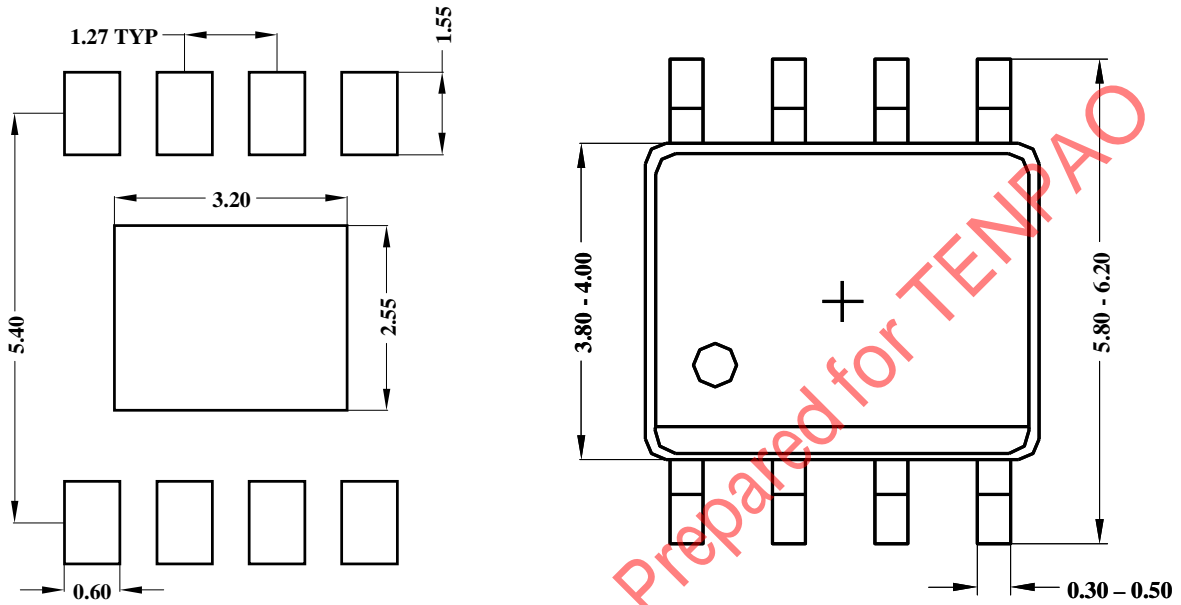

Recommended Pad Layout

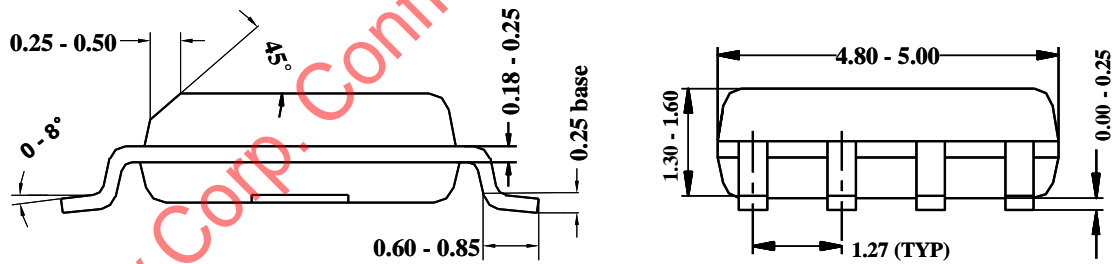

Notes: All dimensions are in millimeters.
 All dimensions don't include mold flash & metal burr.