

High Efficiency 1.5MHz, Dual 1A Synchronous Step Down Regulator

General Description

The SY8831 is a dual output, high efficiency 1.5MHz synchronous step down DC/DC regulator capable of delivering up to 1A output current for each output channel. The SY8831 operates over a wide input voltage range from 2.5V to 5.5V and integrates main switch and synchronous switch with very low $R_{DS(ON)}$ to minimize the conduction loss.

Ordering Information

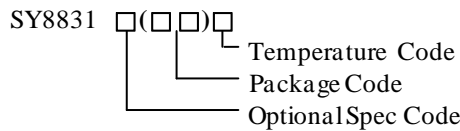

Ordering Number	Package type	Note
SY8831AIC	TSOT23-8	--

Features

- 2.5V to 5.5V Input Voltage
- 1.5MHz Switching Frequency
- 180 °Out of Phase Operation
- Output Current: 1A per Channel
- Quiescent Current: Typical 55 μ A for both Channels
- Low $R_{DS(ON)}$ for Internal Switches (PFET/NFET): 260m Ω /180m Ω
- Internal Soft-start
- 100% Dropout Operation
- RoHS Compliant and Halogen Free
- Compact Package: TSOT23-8

Applications

- SSD
- Cell Phones
- Digital Cameras
- PDAs
- Portable Media Players

Typical Applications

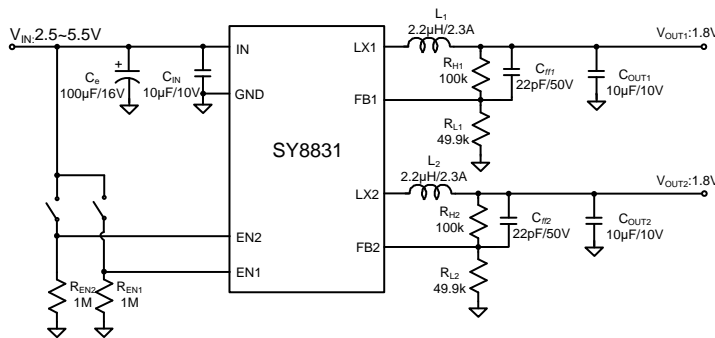

Figure 1. Schematic Diagram

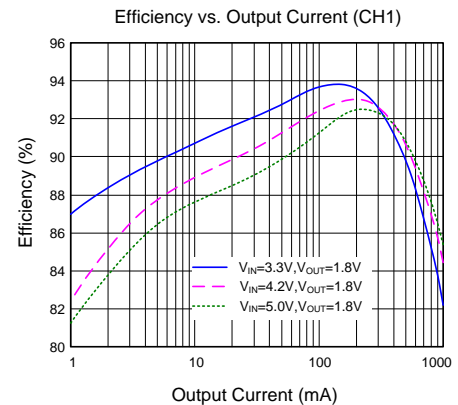
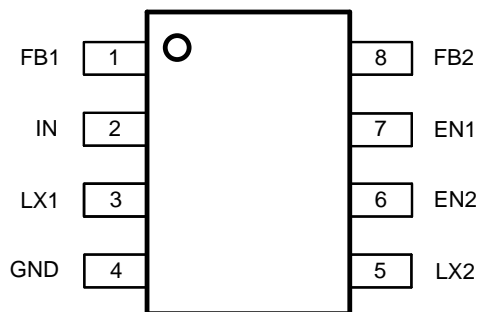

Figure 2. Efficiency vs. Output Current

Pinout (top view)

(TSOT23-8)

Top Mark: Nxyz (Device code: Nb, *x*=year code, *y*=week code, *z*=lot number code)

Pin Name	Pin Number	Pin Description
FB1	1	Feedback pin for channel1. Connect this pin to the center point of the output resistor divider (as shown in Figure 1) to program the output voltage of channel 1: $V_{OUT1}=0.6V \times (1+R_{H1}/R_{L1})$
IN	2	Power input pin. Decouple this pin to ground pin with at least a 10 μ F ceramic capacitor.
LX1	3	Inductor pin for output1. Connect this pin to the switching node of inductor.
GND	4	Ground pin.
LX2	5	Inductor pin for channel 2. Connect this pin to the switching node of inductor.
EN2	6	Enable pin for channel 2. Do not leave it floating.
EN1	7	Enable pin for channel 1. Do not leave it floating.
FB2	8	Feedback pin for channel2. Connect this pin to the center point of the output resistor divider (as shown in Figure 1) to program the output voltage of channel 2: $V_{OUT2}=0.6V \times (1+R_{H2}/R_{L2})$

Function Block

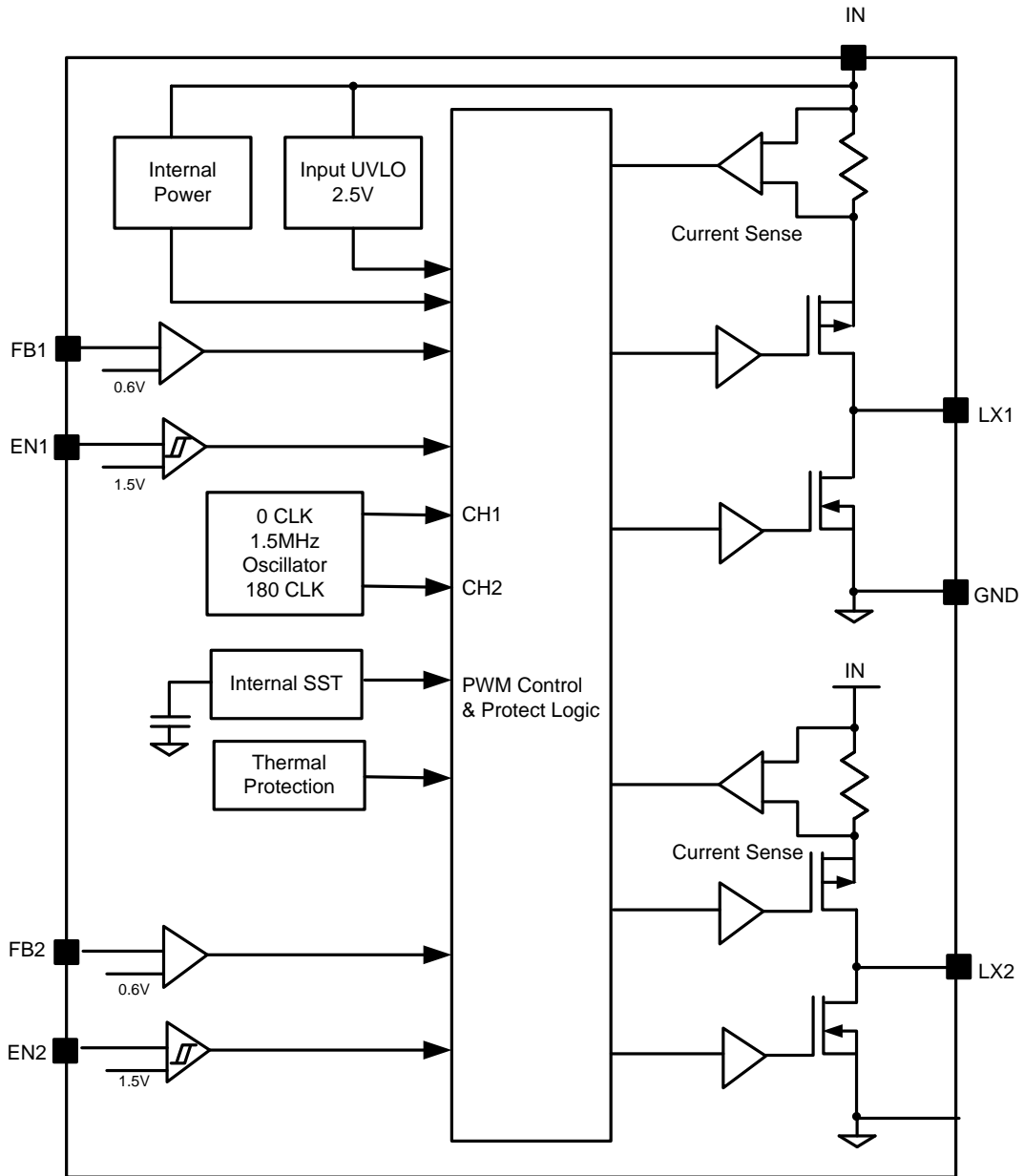

Figure3. Block Diagram



Absolute Maximum Ratings (Note 1)

Supply Input Voltage	-0.3V to 6V
EN1,EN2, FB1,FB2 Voltage	-0.3V to $V_{IN}+0.6V$
LX1, LX2 Voltage	-0.3V ^(*1) to 6V ^(*2)
Power Dissipation, P_D @ $T_A = 25\text{ }^\circ\text{C}$ TSOT23-8	1.8W
Package Thermal Resistance (Note 2)	
θ_{JA}	55 $^\circ\text{C}/\text{W}$
θ_{JC}	8 $^\circ\text{C}/\text{W}$
Junction Temperature Range	150 $^\circ\text{C}$
Lead Temperature (Soldering, 10 sec.)	260 $^\circ\text{C}$
Storage Temperature Range	-65 $^\circ\text{C}$ to 150 $^\circ\text{C}$

(*1) LX1, LX2 voltage tested down to -3V < 20ns
(*2) LX1, LX2 voltage tested up to +7V < 20ns

Recommended Operating Conditions (Note 3)

Supply Input Voltage	2.5V to 5.5V
EN1, EN2, FB1, FB2 Voltage	$V_{IN}+0.3V$
Junction Temperature Range	-40 $^\circ\text{C}$ to 125 $^\circ\text{C}$
Ambient Temperature Range	-40 $^\circ\text{C}$ to 85 $^\circ\text{C}$



Electrical Characteristics

($V_{IN}=5V$, $V_{OUT1}=V_{OUT2}=2.5V$, $L_1=L_2=2.2\mu H$, $C_{OUT1}=C_{OUT2}=10\mu F$, $T_A=25^\circ C$ unless otherwise specified)

Parameter	Symbol	Test Conditions	Min	Typ	Max	Unit
Input Voltage Range	V_{IN}		2.5		5.5	V
Shutdown Current	I_{SHDN}	EN1=EN2=0		0.1	1	μA
Quiescent Current	I_Q	EN1=1 or EN2=1, $I_{OUT1}=I_{OUT2}=0$, no switching		45		μA
		EN1=1 and EN2=1, $I_{OUT1}=I_{OUT2}=0$, no switching		55		μA
Input UVLO Threshold	V_{UVLO}				2.45	V
UVLO Hysteresis	V_{HYS}			0.2		V
Oscillator Frequency	F_{OSC}	PWM operation		1.5		MHz
Thermal Shutdown Temperature	T_{SD}			150		$^\circ C$
Thermal Shutdown Hysteresis	T_{HYS}			20		$^\circ C$
Feedback Reference Voltage	V_{REF1}, V_{REF2}		0.588	0.600	0.612	V
PFET R_{ON}	$R_{DS(ON),P1}$ $R_{DS(ON),P2}$			260		m Ω
NFET R_{ON}	$R_{DS(ON),N1}$ $R_{DS(ON),N2}$			180		m Ω
PFET Current Limit	I_{LIM1}, I_{LIM2}		1.35			A
EN Rising Threshold	V_{ENH1}, V_{ENH2}		1.2			V
EN Falling Threshold	V_{ENL1}, V_{ENL2}				0.4	V
Output Discharge Switch On Resistance	R_{DISCH1}, R_{DISCH2}			35		Ω
PFET Min On time	t_{ON}			80		ns
Internal Soft-start Time	t_{SS1}, t_{SS2}			1		ms

Note 1: Stresses beyond the “Absolute Maximum Ratings” may cause permanent damage to the device. These are stress ratings only. Functional operation of the device at these or any other conditions beyond those indicated in the operational sections of the specification is not implied. Exposure to absolute maximum rating conditions for extended periods may affect device reliability.

Note2: Package thermal resistance of SY8831AIC is measured in the natural convection at $T_A=25^\circ C$ on a four-layer Silergy evaluation board.

Note 3: The device is not guaranteed to function outside its operating conditions

TSOT23-8 Package Outline Drawing

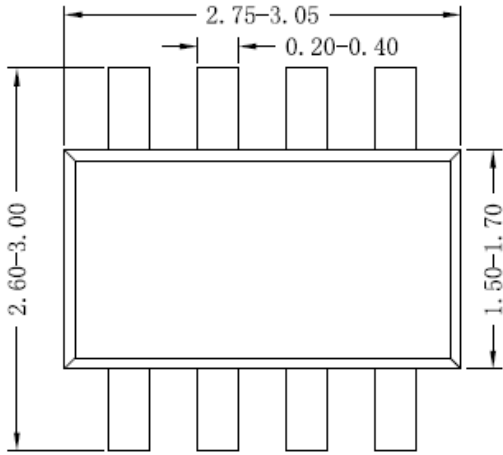

Top view

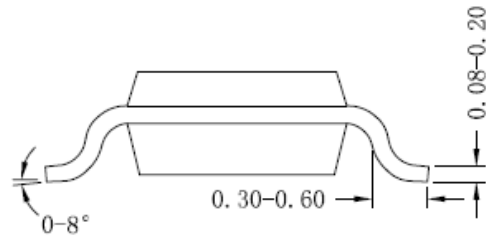

Side view A

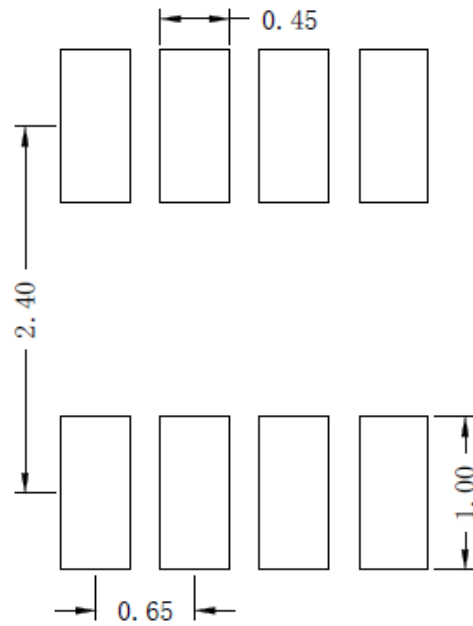

**Recommended PCB layout
(Reference only)**

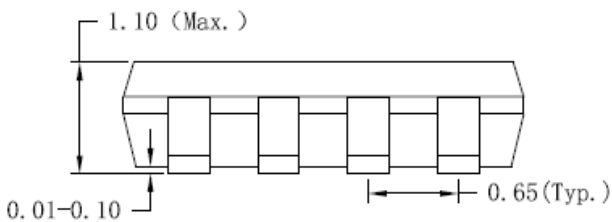

Side view B

Notes: All dimension in millimeter and exclude mold flash & metal burr

Taping & Reel Specification

1. Taping orientation

TSOT23-8

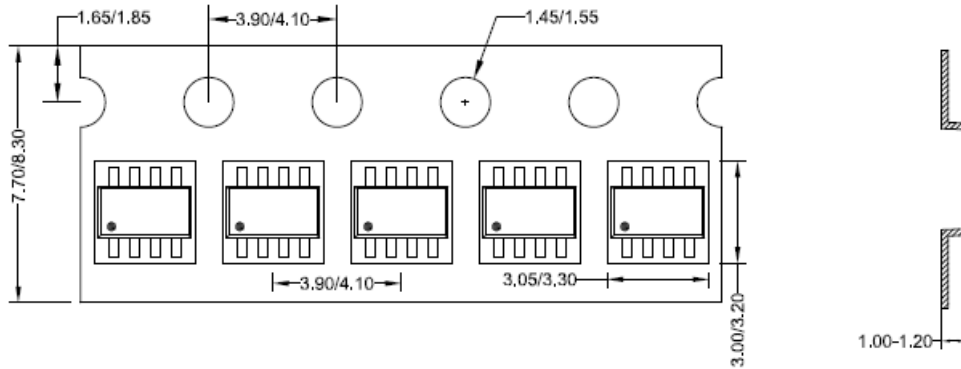

Feeding direction \longrightarrow

2. Carrier Tape & Reel specification for packages

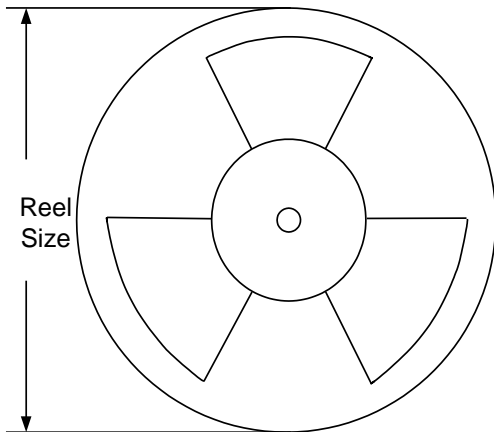

Package type	Tape width (mm)	Pocket pitch(mm)	Reel size (Inch)	Trailer * length(mm)	Leader * length (mm)	Qty per reel (pcs)
TSOT23-8	8	4	7	400	160	3000

3. Others: NA