



Features

- 100mΩ Typ. High-Side MOSFET
- 2.5A Current Limit
- Low Quiescent Current: 60μA
- Wide Input Voltage Range: 2V to 5.5V
- Thermal Protection
- Small MSOP-8L Package Minimizes Board

Space

Applications

- Battery-Powered Equipment
- Hot-Plug Power Supplies
- Battery-Charger Circuits
- USB Device Power Switch
- Motherboard USB Power Switch

Description

The HX9014 is an integrated 100mΩ power switch for self-powered and bus-powered Universal Series Bus (USB) applications. Its low quiescent supply current (60μA) and small package (MSOP-8L) is particularly suitable in battery-powered portable equipment.

Several protection functions include soft start to limit inrush current during plug-in, current limiting at 2.5A to meet USB power requirement, and thermal shutdown to protect damage under over current condition.

Ordering Information

HX9014–① ②:

SYMBOL	DESCRIPTION
①	Operating Temperature Range: Commercial standard
②	Denotes Package Types: D: MSOP-8L

Typical Application Circuit

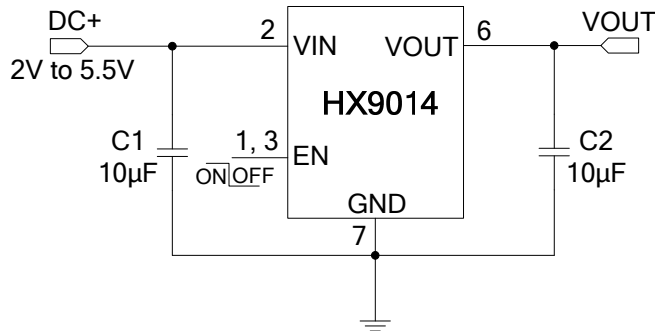

Pin Assignment and Description

TOP VIEW	PIN	NAME	DESCRIPTION
		1, 3	EN
	2	VIN	Input Supply Voltage
	4, 5, 8	N/C	No Connect
	6	VOUT	Output Voltage
	7	GND	Ground

Absolute Maximum Ratings (Note 1)

- Maximum Supply Voltage7V
- Chip Enable.....-0.3V ~ 7V
- Operating Temperature(Note 2).....-40°C ~ +85°C
- Junction Temperature Range.....-40°C ~ +125°C
- Storage Temperature Range.....-65°C ~+150°C
- Lead Temperature.....+265°C

Note 1: Stresses listed as the above “Absolute Maximum Ratings” may cause permanent damage to the device. Exposure to absolute maximum rating conditions for extended periods may remain possibility to affect device reliability.

Note 2: The HX9014 is guaranteed to meet performance specifications from 0°C to 70°C. Specifications over the -40°C to 85°C operating temperature range are assured by design, characterization and correlation with statistical process controls.

Electrical Characteristics

Operating Conditions: $T_A=25^{\circ}\text{C}$, $V_{IN}=5\text{V}$, $C_{IN}=10\mu\text{F}$, $C_{OUT}=10\mu\text{F}$, unless otherwise specified.

SYMBOL	PARAMETER	CONDITIONS	MIN	TYP	MAX	UNITS
V_{IN}	Input Voltage Range		2		5.5	V
I_Q	Supply Current	$V_{IN}=3\text{V}$		90		μA
		$V_{IN}=5\text{V}$		150		μA
I_{SHDN}	Shutdown Supply Current	EN="0"		1.2		μA
I_{LIM}	Current Limit Threshold			2.5		A
$R_{DS(ON)}$	Output NMOFET $R_{DS(ON)}$	$V_{IN}=5\text{V}$, $I_{LOAD}=1\text{A}$		100		$\text{m}\Omega$
T_R	Output Turn-On Rising Time	$I_{LOAD}=0\text{mA}$		25		μs
V_{ENH}	EN Input High Threshold		1.6			V
V_{ENL}	EN Input Low Threshold				0.6	V
V_{UVLO}	V_{IN} Under Voltage Lockout			1.8		V
T_{SD}	Thermal Limit			130		$^{\circ}\text{C}$
ΔT_{SD}	Thermal Limit Hysteresis			20		$^{\circ}\text{C}$

Typical Operating Characteristics

Output Voltage vs. Output Current

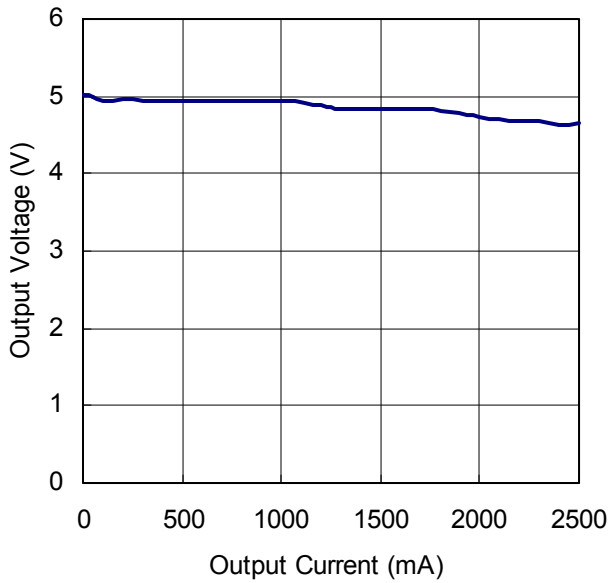

Quiescent Current vs. Supply Voltage (I_o=0A)

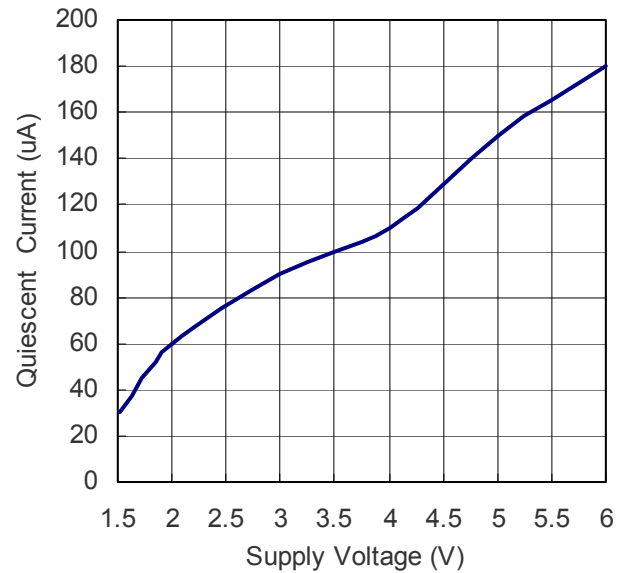

EN Threshold Voltage vs. Input Voltage

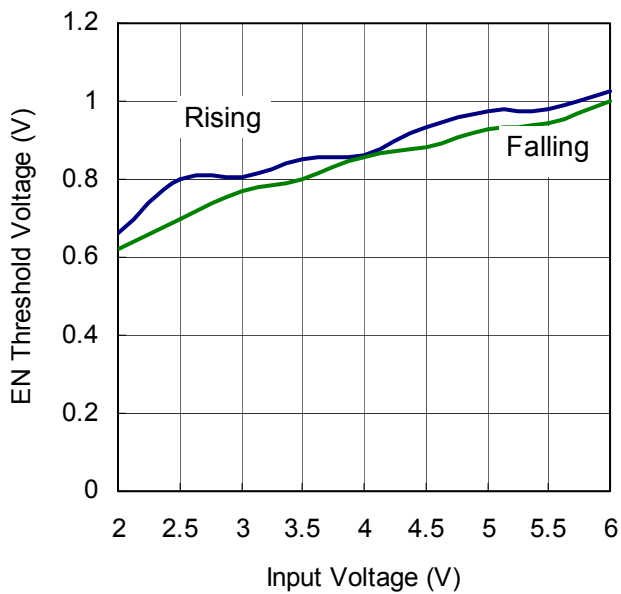

Turn - On Response

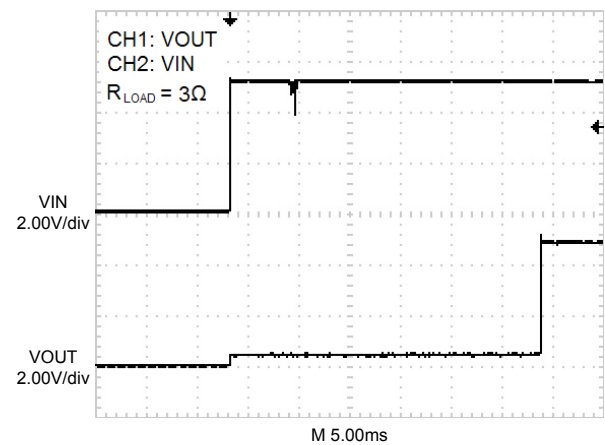

Pin Functions

EN (Pin 1, 3): Chip Enable (Active High). Pull these pins high to enable the IC. Tie to GND to shut down the IC. Never let these pins floating.

VIN (Pin 2): Input Supply Voltage. When operating HX9014 as a switch it must be bypassed with a low ESR ceramic capacitor.

N/C (Pin 4, 5, 8): No Connect.

VOUT (Pin 6): Output Voltage. Bypass VOUT with ESR capacitor. However stability improves with higher ESRs.

GND (Pin 7): Ground for the IC.

Block Diagram

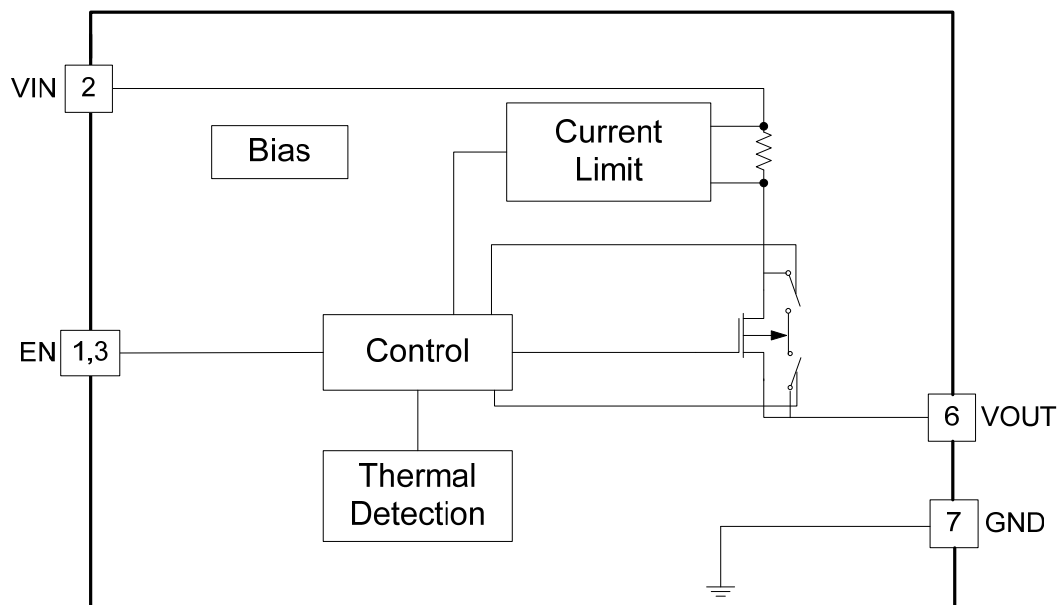

Application Information

The HX9014 is a high-side single switch with active-high enable input.

Input and Output

VIN (input) is the power supply connection to the circuitry and the drain of the output MOSFET. VOUT (output) is the source of the output MOSFET. In a typical circuit, current flows through the switch from VIN to VOUT toward the load. VOUT pin must be short on the board and connected to the load and so do VIN pin but connected to the power source.

Thermal Shutdown

Thermal shutdown shuts off the output MOSFET if the die temperature exceeds 130°C and 20°C of hysteresis forces the switch turning off until the die temperature drops to 110°C.

Under-voltage Lockout

UVLO prevents the MOSFET switch from turning on until input voltage exceeds 1.8V (typical). If input voltage drops below 1.8V (typical), UVLO shuts off the MOSFET switch.

Current Limiting and Short Protection

The current limit circuit is designed to protect the system supply, the MOSFET switch and the load from damage caused by excessive currents. The current limit threshold is set internally to limit the output current to approximately 2.5A typical. When a heavy load or short circuit is applied to an enabled switch, a large transient current may flow until the current limit circuitry responds. Once this current limit threshold is exceeded the device enters constant current mode until the thermal shutdown occurs or the fault is removed.

Filtering

To limit the input voltage drop during hot-plug events connect a 10μF ceramic capacitor from VIN to GND. However, higher capacitor values will further reduce the voltage drop at the input.

Connect a sufficient capacitor from VOUT to GND. This capacitor helps to prevent inductive parasitics from pulling VOUT negative during turn-off or EMI damage to other components during the hot detachment. It is also necessary for meeting the USB specification during hot plug-in operation. If HX9014 is implanted in device end application, minimum 10μF capacitor from VOUT to GND is recommended and higher capacitor values are also preferred.

In choosing these capacitors, special attention must be paid to the Effective Series Resistance, ESR, of the capacitors to minimize the IR drop across the capacitor's ESR. A lower ESR on this capacitor can get a lower IR drop during the operation.

Ferrite beads in series with all power and ground lines are recommended to eliminate or significantly reduce EMI. In selecting a ferrite bead, the DC resistance of the wire used must be kept to a minimum to reduce the voltage drop.

Layout and Thermal Dissipation

1. Place the switch as close to the USB connector as possible. Keep all traces as short as possible to

reduce the effect of undesirable parasitic Inductance.

2. Place the output capacitor and ferrite beads as close to the USB connector as possible. If ferrite beads are used, use wires with minimum resistance and large solder pads to minimize connection resistance.

3. Under normal operating conditions, the package can dissipate the channel heat away. Wide power bus planes connected to VIN and VOUT and a ground plane in contact with the device will help dissipate additional heat.

Packaging Information

MSOP-8L Package Outline Dimension

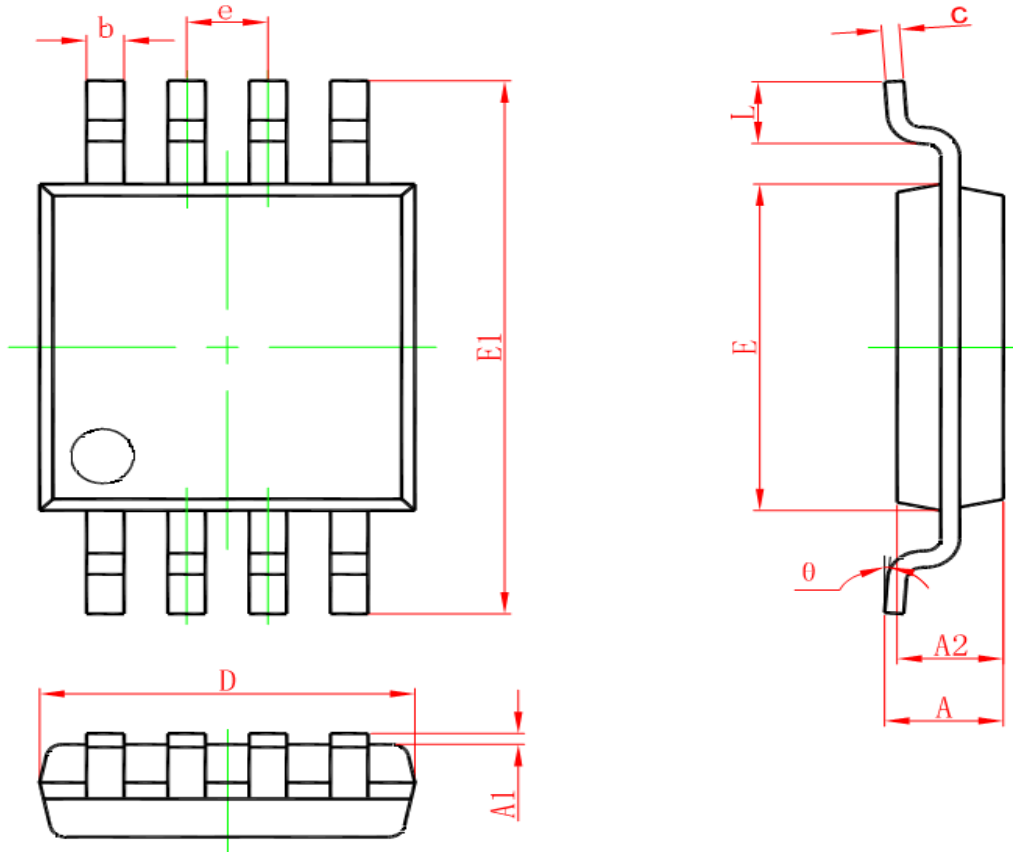

Symbol	Dimensions In Millimeters		Dimensions In Inches	
	Min	Max	Min	Max
A	0.820	1.100	0.032	0.043
A1	0.020	0.150	0.001	0.006
A2	0.750	0.950	0.030	0.037
b	0.250	0.380	0.010	0.015
c	0.090	0.230	0.004	0.009
D	2.900	3.100	0.114	0.122
e	0.650(BSC)		0.02(BSC)	
E	2.900	3.100	0.114	0.122
E1	4.750	5.050	0.187	0.199
L	0.400	0.800	0.016	0.031
θ	0°	6°	0°	6°

Subject changes without notice.