

General Description

SY6983 is a 3.6-12.8V input voltage, 1A three-cell synchronous Boost Li-Ion battery charger which integrates 500kHz switching frequency and full protection functions. The charge current up to 1A can be programmed by using an external resistor for different portable applications and indicates the charge current information simultaneously. It also has a programmable charge timeout for safe battery charge operation and a programmable input voltage threshold for adaptive input current limit. SY6983 can disconnect output when there is an output short circuit or shutdown. It consists of 18V rating FETs with extremely low ON resistance to achieve high charge efficiency and simple peripheral circuit design.

SY6983 along with small QFN3×3 footprint provides small PCB area application.

Ordering Information

SY6983 □(□)□□

- └─ Temperature Code
- └─ Package Code
- └─ Optional Spec Code

Ordering Number	Package type	Note
SY6983QDC	QFN3×3-16	

Features

- Low Profile QFN3×3 Package
- Integrated Synchronous Boost with 18V Rating
- Low $R_{DS(ON)}$ FETs for High Charge Efficiency
- Trickle Current / Constant Current / Constant Voltage Charge Mode
- Programmable Input Voltage Threshold for Adaptive Current Limit
- Maximum 1A Constant Charge Current
- Charge Current Information Indication
- Programmable Charge Timeout
- Programmable Constant Charge Current
- Selectable Constant Voltage
- $\pm 0.5\%$ Battery Voltage Accuracy
- Thermal Regulation Protection
- External Shutdown Function
- Input Voltage UVLO and OVP
- Over Temperature Protection
- Output Short Circuit Protection
- Charge Status Indication
- Normal Synchronous Boost Operation when the Battery is Removed

Applications

- Cellular Telephones, PDA, MP3 Players, MP4 Players
- Digital Cameras
- Bluetooth Applications
- PSP Game Players, NDS Game Players
- Notebook

Typical Application

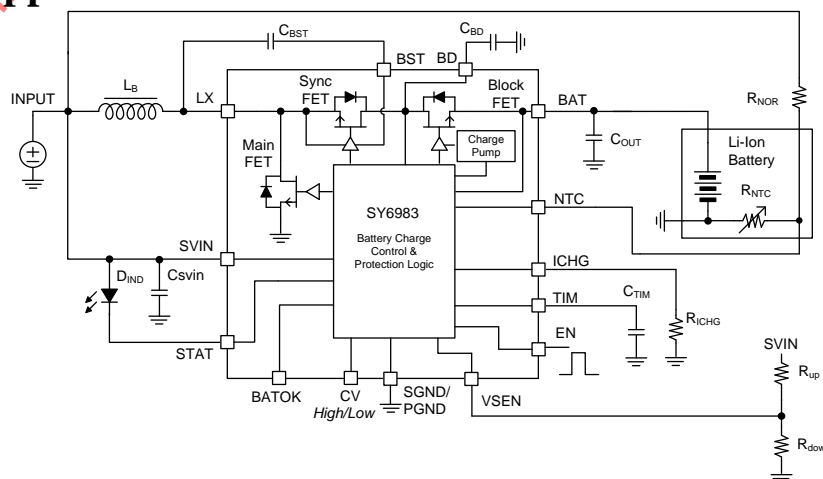
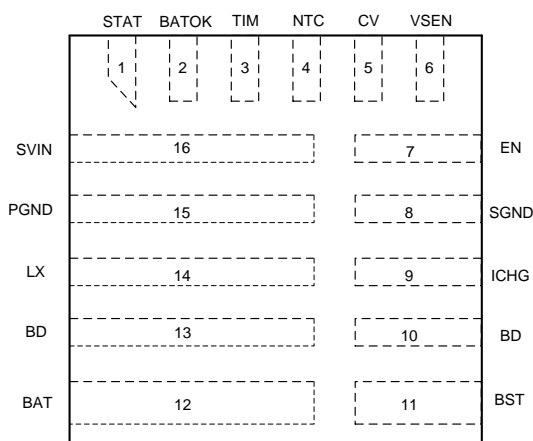

Figure1. Schematic Diagram

Pinout (Top View)

(QFN3x3-16)

 Top Mark: **BQWxyz**, (Device code: **BQW**, *x=year code, y=week code, z=lot number code*)

Pin Name	Pin Number	Pin Description
STAT	1	Charge status indication pin. It is an open drain output pin and pulled high to SVIN through a LED which indicates the charge in process. When the charge is done, LED will be off.
BATOK	2	Good battery present indication pin. When V_{BAT} is lower than 9.1V or NTC is pulled up to SVIN, BATOK pin will output low logic. Otherwise, BATOK pin will output high logic.
TIM	3	Charge time limit pin. Connect this pin with a capacitor to ground. Internal current source charge the capacitor for TC mode and CC mode's charge time limit. TC charge time limit is about 1/9 of CC charge time limit.
NTC	4	Thermal protection pin. UTP threshold is typically 76% of V_{SVIN} and OTP threshold is typically 46.5% of V_{SVIN} . Pulling up to SVIN can disable charge logic and make the IC operate as a normal Boost regulator. Pull down to ground can shut down the IC.
CV	5	Battery CV voltage selection pin. Pull down for 12.6V CV voltage and pull up for 13.05V CV voltage.
VSEN	6	Voltage sense of SVIN. If the voltage drops to internal 1.195V reference voltage, the SVIN will be clamped to set value and the input current will be limited.
EN	7	Enable control pin. High logic for enable on, and low logic for enable off.
SGND	8	Signal ground pin.
ICHG	9	Charge current program pin. Pull down to GND with a resistor R_{ICHG} . The mirror current about 1/10000 of the blocking FET current will dump into the external RC network through ICHG pin and be compared to the internal reference 1V. So $I_{CC}=(1V/R_{ICHG})\times 10k$, $I_{TC}=(1V/R_{ICHG})\times 1k+0.03$.
BD	10, 13	Connect to the drain of internal Blocking FET. Bypass at least 4.7 μ F ceramic cap to GND.
BST	11	Boost-Strap pin. Supply Rectified FET's gate driver. Decouple this pin to LX with a 0.1 μ F ceramic cap.
BAT	12	Battery positive pin.
LX	14	Switch node pin. Connect it to the external inductor.
PGND	15	Power ground pin.
SVIN	16	Analog power input pin. Connect a MLCC from this pin to ground to decouple high harmonic noise. This pin has OVP and UVLO function to make the charger operate within safe input voltage range.

Absolute Maximum Ratings (Note1)

STAT, NTC, CV, VSEN, EN, ICHG, BD, BAT, LX, SVIN	-----	18V
BATOK, TIM, BST-LX	-----	4V
LX Pin Current Continuous	-----	5A
Power Dissipation, P _D @ T _A = 25 °C, QFN3×3	-----	2.6W
Package Thermal Resistance (Note2)		
θ _{JA}	-----	38 °C/W
θ _{JC}	-----	4 °C/W
Junction Temperature Range	-----	-40 °C to 125 °C
Lead Temperature (Soldering, 10 sec.)	-----	260 °C
Storage Temperature Range	-----	-65 °C to 125 °C

Recommended Operating Conditions (Note3)

SVIN	-----	3.6V to 12.8V
STAT, NTC, CV, VSEN, EN, ICHG, BD, BAT, LX,	-----	-0.3V to 16V
BATOK, TIM, BST-LX	-----	-0.3V to 3.3V
LX Pin Current Continuous	-----	5A
Junction Temperature Range	-----	-40 °C to 125 °C
Ambient Temperature Range	-----	-40 °C to 85 °C

Silergy Confidential-For 半导体芯

Electrical Characteristics

$T_A=25\text{ }^\circ\text{C}$, $V_{IN}=5\text{V}$, $GND=0\text{V}$, $C_{IN}=4.7\text{ }\mu\text{F}$, $L=2.2\text{ }\mu\text{H}$, $R_{ICHG}=10\text{k}\Omega$, $C_{TIM}=470\text{nF}$, unless otherwise specified.

Parameter	Symbol	Test Conditions	Min	Typ	Max	Unit
Bias Supply (V_{SVIN})						
Supply Voltage	V_{SVIN}		3.6		16	V
V_{SVIN} Under Voltage Lockout Threshold	V_{UVLO}	V_{SVIN} rising and measured from V_{SVIN} to GND			3.5	V
V_{SVIN} Under Voltage Lockout Hysteresis	ΔV_{UVLO}	Measured from V_{SVIN} to GND		100		mV
Input Overvoltage Protection	V_{OVP}	V_{SVIN} rising and measured from V_{SVIN} to GND	12.9			V
Input Overvoltage Protection Hysteresis	ΔV_{OVP}	Measured from V_{SVIN} to GND		0.45		V
Quiescent Current						
Battery Discharge Current	I_{BAT}	Shutdown IC, EN=NTC=0			10	μA
Input Quiescent Current	I_{IN}	Disable Charge, EN=1, NTC=0			1	mA
Oscillator and PWM						
Switching Frequency	f_{SW}			500		kHz
Main N-FET Minimum OFF Time	t_{MIN_OFF}	With 18V rating		100		ns
Main N-FET Maximum OFF Time	t_{MAX_OFF}	With 18V rating		30		μs
Main N-FET Minimum ON Time	t_{MIN_ON}	With 18V rating		100		ns
Power MOSFET						
$R_{DS(ON)}$ of Main N-FET	R_{NFET_M}			80		$\text{m}\Omega$
$R_{DS(ON)}$ of Rectified N-FET	R_{NFET_R}			40		$\text{m}\Omega$
$R_{DS(ON)}$ of Blocking N-FET	R_{NFET_B}			40		$\text{m}\Omega$
Voltage Regulation						
Battery Charge Voltage	V_{BAT_REG}	$V_{CV}<1\text{V}$	12.537	12.6	12.663	V
		$V_{CV}>2\text{V}$	12.985	13.05	13.115	
High Level Logic for CV	V_{CV_H}		2			V
Low Level Logic for CV	V_{CV_L}				1	V
Recharge Threshold Refer to V_{BAT_REG}	ΔV_{RCH}		150	300	450	mV
Trickle Current Charge Mode Battery Voltage Threshold	V_{TRK}		8.1	8.4		V

Battery Connect Detection						
NTC Voltage Threshold for Battery Detect	V_{DET}	NTC falling edge	85%		95%	V_{SVIN}
Detect Delay Time	t_{DET}			30		ms
Charge Current						
Internal Charge Current Accuracy for Constant Current Mode		$I_{CC}=1000mA$	-10%		10%	
Internal Charge Current Accuracy for Trickle Current Mode		$I_{TC}=130mA$	-50%		50%	
Termination Current	I_{TERM}	$I_{CC}=1000mA$	50	100	150	mA
Output Voltage OVP						
Output Voltage OVP Threshold	V_{OVP}		105%	110%	115%	V_{BAT_REG}
Input Voltage Threshold for Adaptive Current Limit						
Voltage Reference of V_{SEN}	V_{SEN}	$V_{SVIN} \leq 6V$	1.171	1.195	1.219	V
The Adaptive Input Power Limit Reference is $V_{SVIN}-\Delta V_{AICL}$	ΔV_{AICL}	$V_{SVIN} > 6V$		0.53		V
Timer						
Trickle Current Charge Timeout	t_{TC}	$C_{TIM}=330nF$	0.4	0.5	0.65	hour
Constant Current Charge Timeout	t_{CC}		3.8	4.5	5.82	hour
Charge Mode Change Delay Time	t_{MC}			30		ms
Termination Delay Time	t_{TERM}			30		ms
Recharge Time Delay	t_{RCHG}			30		ms
Short Circuit Protection						
Output Short Protection Threshold is $V_{SVIN} - \Delta V_{SHORT}$	ΔV_{SHORT}			2.3		V
BATOK Indication						
BATOK High Voltage Output	V_{BATOK_H}			3		V
BATOK Low Voltage Output	V_{BATOK_L}			0		V
Linear Charger Mode						
Battery Charger Current when the Blocking FET is in Linear Mode	I_{SC}	$V_{BAT} < V_{SVIN} - \Delta V_{SHORT}$ when $I_{CC}=1000mA$		130		mA
BD Voltage Regulation	V_{BD}			9.24		V
Enable ON/OFF Control						
High Level Logic for Enable Control	V_{EN_H}		1.5			V
Low Level Logic for Enable Control	V_{EN_L}				0.4	V

Battery Thermal Protection NTC						
Under Temperature Protection	V_{NTC_UTP}		75%	76%	77%	V _{SVIN}
Under Temperature Protection Hysteresis	$V_{NTC_UTP_HYS}$	Falling edge		6%		
Over Temperature Protection	V_{NTC_OTP}		45.5%	46.5%	47.5%	
Over Temperature Protection Hysteresis	$V_{NTC_OTP_HYS}$	Rising edge		2%		
Thermal Fold-back and Thermal Shutdown						
Thermal Fold-back Threshold	T_{Fold}	Rising edge		120		°C
Thermal Fold-back Threshold Hysteresis	T_{Fold_HYS}			20		°C
Thermal Fold-back Ratio				0.25		I _{CC}
Thermal Shutdown Temperature	T_{SD}	Rising edge		160		°C
Thermal Shutdown Temperature Hysteresis	T_{SD_HYS}			30		°C

Note 1: Stresses beyond the “Absolute Maximum Ratings” may cause permanent damage to the device. These are stress ratings only. Functional operation of the device at these or any other conditions beyond those indicated in the operational sections of the specification is not implied. Exposure to absolute maximum rating conditions for extended periods may affect device reliability.

Note 2: θ_{JA} is measured in the natural convection at $T_A = 25\text{ °C}$ on a low effective four-layer thermal conductivity test board of JEDEC 51-3 thermal measurement standard.

Note 3: The device is not guaranteed to function outside its operating conditions

QFN3×3-16 Package Outline Drawing

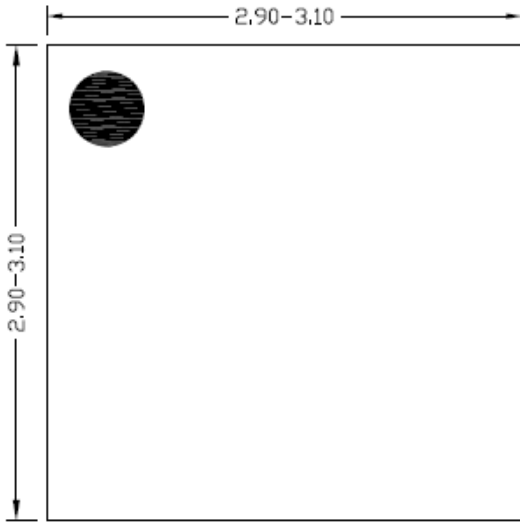

Top View

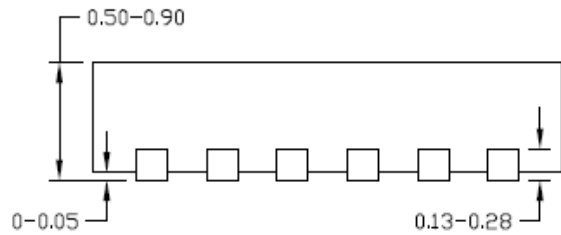

Side View

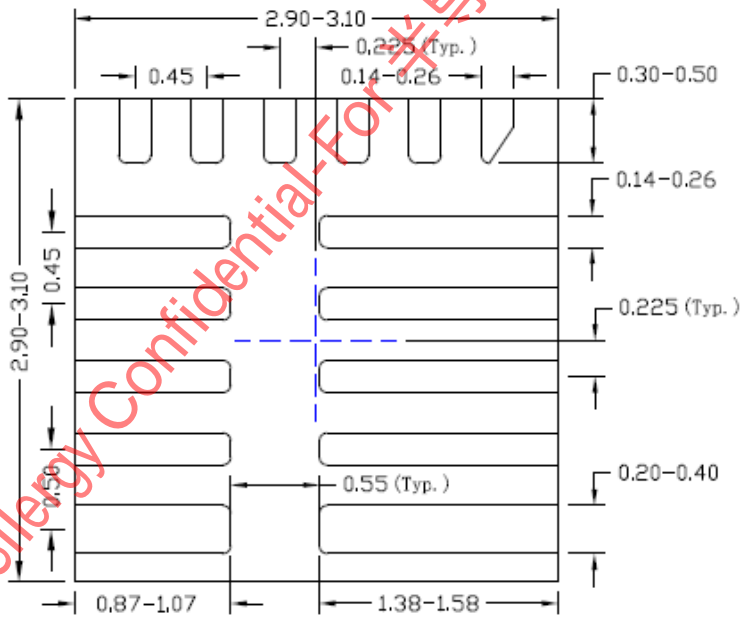

Bottom View

Notes: All dimension in millimeter and exclude mold flash & metal burr.

