

1A LOW DROPOUT VOLTAGE REGULATOR

Description

The AMS1117 is a series of low dropout voltage regulators which can provide up to 1A of output current. The AMS1117 is available in six fixed voltage, 1.2, 1.5, 1.8, 2.5, 3.3 and 5.0V. Additionally it is also available in adjustable version. On chip precision trimming adjusts the reference/ output voltage to within $\pm 2\%$. On-chip thermal limiting provides protection against any combination of overload and ambient temperatures that would create excessive junction temperatures.

The AMS1117 series is available in SOT-223, TO-252, SOT89 packages. A minimum of 10uF tantalum capacitor is required at the output to improve the transient response and stability.

Features

- ◆ Low Dropout Voltage.
- ◆ Load regulation: 0.5% Max.
- ◆ Optimized for Low Voltage
- ◆ On-chip thermal limiting.
- ◆ Maximum Input Voltage : 30V
- ◆ Adjustable Output Voltage or Fixed 1.2V, 1.5V, 1.8V, 2.5V, 3.3V,5V
- ◆ Standard SOT-223,TO-252 ,SOT89 Packages

Applications

- ◆ Post Regulator for switching DC/DC Converter
- ◆ High Efficiency Linear Regulator
- ◆ Battery Chargers
- ◆ PC Add on Card
- ◆ Motherboard clock supplies
- ◆ LCD Monitor r
- ◆ Set-top Box

Block Diagram

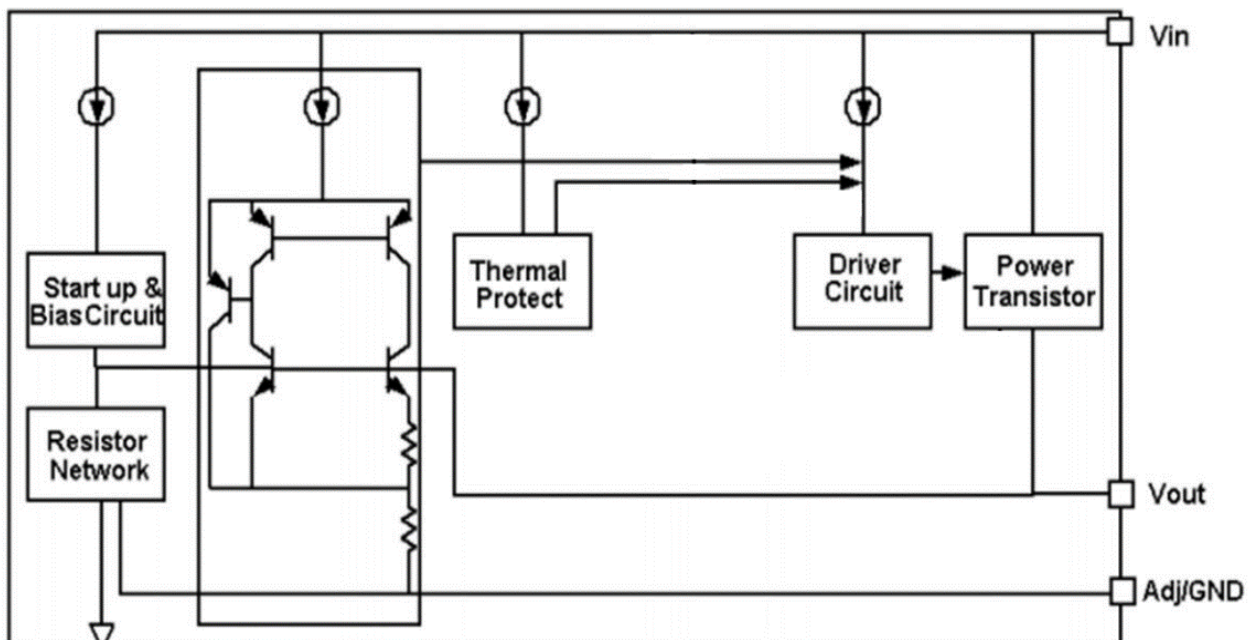

Pin Description

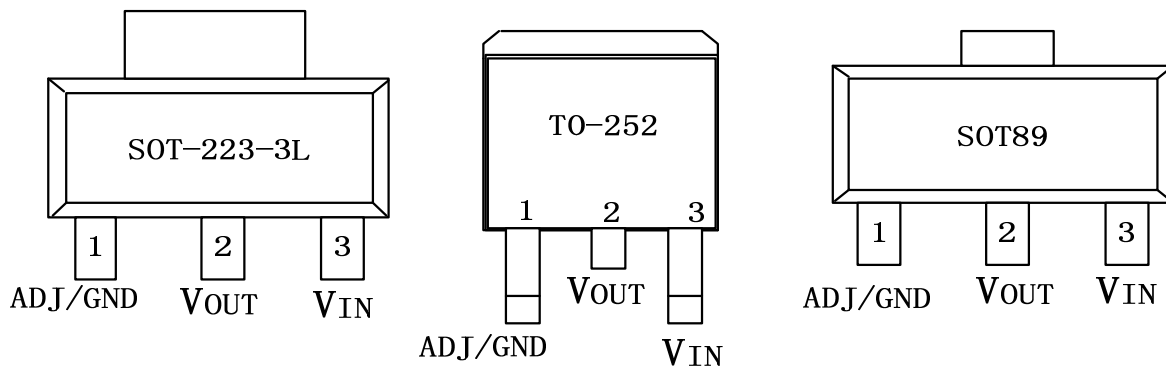

Absolute Maximum Ratings

| Symbol | Description | Max | Units |
|------------------|--------------------------------------|---|-------|
| V _{IN} | Input Voltage | 30 | V |
| I _{OUT} | DC Output Current | PD/(V _{IN} -V _{OUT}) | mA |
| T _J | Operating Junction Temperature Range | -40 to 125 | °C |
| θ _{JA} | Thermal Resistance (SOT-223) | 150 | °C/W |
| θ _{JA} | Thermal Resistance (TO-252) | 125 | °C/W |
| θ _{JA} | Thermal Resistance (SOT89) | 225 | °C/W |
| PD | Maximum Power Dissipation (SOT-223) | 600 | mW |
| PD | Maximum Power Dissipation (TO-252) | 900 | mW |
| PD | Maximum Power Dissipation (SOT89) | 400 | mW |

Electrical Characteristics ($V_{in} \leq 7V$, $T_j = 25^\circ C$ unless otherwise Specified. The ~ denotes specifications which apply over the specified operating temperature range .)

| Parameter | Conditions | Min. | Typ. | Max. | Units |
|--|--|------------|-------|------------|----------------|
| Reference voltage | $V_{IN} = V_{out} + 2V$, $10mA \leq I_{OUT} \leq 1A$ AMS1117-ADJ | 1.225(-2%) | 1.250 | 1.275(+2%) | V |
| Output voltage | $10mA \leq I_{OUT} \leq 1A$, $V_{IN} = V_{out} + 2V$ | | | | V |
| | AMS1117-1.2 | 1.176 | 1.20 | 1.224 | |
| | AMS1117-1.5 | 1.470 | 1.50 | 1.530 | |
| | AMS1117-1.8 | 1.764 | 1.80 | 1.836 | |
| | AMS1117-2.5 | 2.450 | 2.50 | 2.550 | |
| | AMS1117-3.3 | 3.234 | 3.30 | 3.366 | |
| AMS1117-5.0 | 4.90 | 5.0 | 5.10 | | |
| Line regulation ^{1,2} | $(V_{OUT} + 1.5V) \leq V_{IN} \leq 12V$, $I_{OUT} = 10mA$ | | 0.15 | 0.30 | % |
| Load regulation ^{1,2} | $(V_{IN} - V_{OUT}) = 2V$, $10mA \leq I_{OUT} \leq 1A$ | | 0.20 | 0.50 | % |
| Dropout voltage | $V_{REF} = 1\%$, $I_{OUT} = 1A$ | | 1.30 | 1.40 | V |
| Current limit | $(V_{IN} - V_{OUT}) = 2V$ | 1 | | | A |
| Adjust pin current | AMS1117-ADJ $1.5V \leq (V_{IN} - V_{OUT}) \leq 7V$, $10mA \leq I_{OUT} \leq 1A$ | | 50 | 120 | μA |
| Minimum load current | $1.5V \leq (V_{IN} - V_{OUT}) \leq 12V$ | | 3 | 10 | mA |
| Quiescent current | $V_{IN} = V_{OUT} + 1.25V$ | | 3 | 10 | mA |
| Ripple rejection | $f = 120Hz$, $C_{out} = 22\mu F$ Tantalum , $(V_{IN} - V_{OUT}) = 3V$, $I_{out} = 1A$ | 60 | 70 | | dB |
| Thermal regulation | $T_A = 25^\circ C$, 30ms pulse | | 0.008 | 0.04 | %/W |
| Temperature stability | | | 0.5 | | % |
| Long-term stability | $T_A = 125^\circ C$, 1000hrs. | | 0.3 | 1.0 | % |
| RMS output noise (%of V _{OUT}) | $T_A = 25^\circ C$, $10Hz \leq f \leq 10kHz$ | | 0.003 | | % |
| Thermal resistance, junction to case | SOT-223 | | 15 | | $^\circ C / W$ |
| | TO-252 | | 10 | | $^\circ C / W$ |
| | SOT89 | | 20 | | $^\circ C / W$ |
| Thermal shutdown | Junction temperature | | 150 | | $^\circ C$ |
| Thermal shutdown hysteresis | | | 10 | | $^\circ C$ |

- 1、 See thermal regulation specifications for changes in output voltage due to heating effects. Load and line regulation are measured at a constant junction temperature by low duty cycle pulse testing.
- 2、 Line and load regulation are guaranteed up to the maximum power dissipation (1.2W). Power dissipation is determined by input/output differential and the output current. Guaranteed maximum output power will not be available over the full input/ output voltage range.
- 3、 Output current must be limited to meet the absolute maximum ratings of the part.

Typical Performance Characteristics (TA=25°C, unless otherwise noted.)

Line regulation
AMS1117-ADJ Vout Vs. Vin

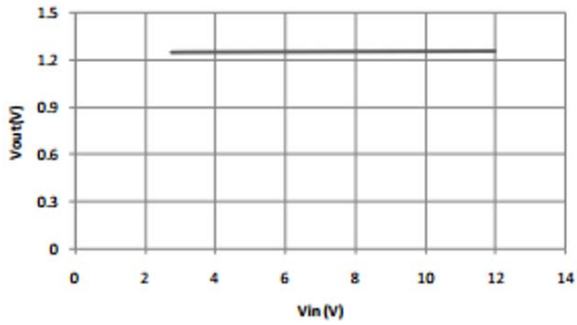

Dropout Voltage
AMS1117 Dropout Voltage

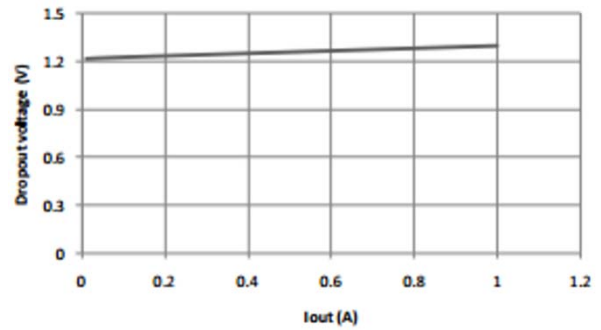

Load regulation
AMS1117-ADJ Vout Vs. Iout

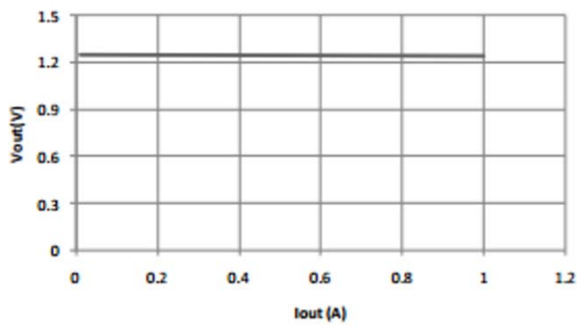

Thermal performance with OTP
AMS1117 Thermal performance with OTP

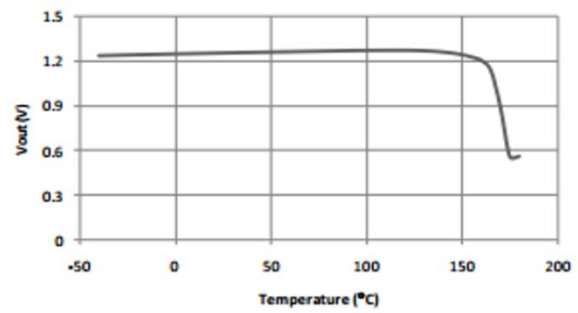

Application Information

Output voltage adjustment

The AMS1117 regulates the output by comparing the output voltage to an internally generated reference voltage. On the adjustable version as shown in Fig.1, the VREF is available externally as 1.25V between VOUT and ADJ. The voltage ratio formed by R1 and R2 should be set to conduct 10mA (minimum output load).

The output voltage is given by the following equation:

$$V_{OUT} = V_{REF} (1 + R2/R1) + I_{ADJ} \times R2$$

On fixed versions of AMS1117, the voltage divider is provided internally

Figure 1. Basic Adjustable Regulator

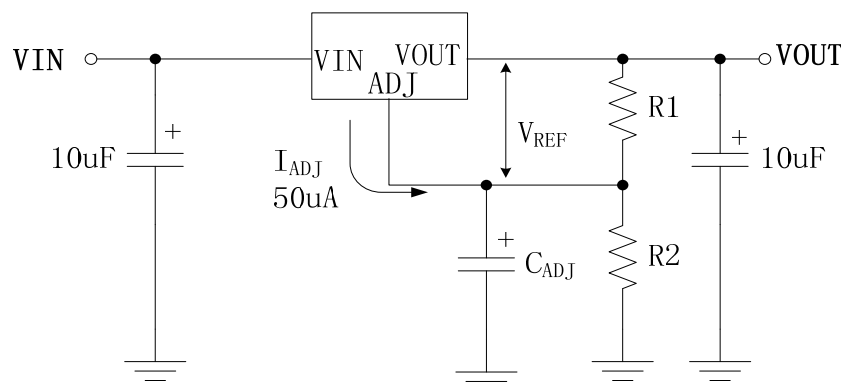

Input Bypass Capacitor

An input capacitor is recommended. A 10µF tantalum on the input is a suitable input bypassing for almost all applications.

Adjust Terminal Bypass Capacitor

The adjust terminal can be bypassed to ground with a bypass capacitor (CADJ) to improve ripple rejection. This bypass capacitor prevents ripple from being amplified as the output voltage is increased. At any ripple frequency, the impedance of the CADJ should be less than R1 to prevent the ripple from being amplified:

$$(2\pi * f_{RIPPLE} * C_{ADJ}) < R1$$

The R1 is the resistor between the output and the adjust pin. Its value is normally in the range of 100- 200Ω. For e

Output Capacitor

AMS1117 requires a capacitor from VOUT to GND to provide compensation feedback to the internal gain stage. This is to ensure stability at the output terminal. Typically, a 10µF tantalum or 50µF aluminum electrolytic is sufficient.

Note: It is important that the ESR for this capacitor does not exceed 0.5 Ω.

The output capacitor does not have a theoretical upper limit and increasing its value will increase stability. COUT = 100µF or more is typical for high current regulator design. Example, with R1 = 124Ω and fRIPPLE = 120Hz, the CADJ should be > 11µF.

Load Regulation

When the adjustable regulator is used (Fig.2), the best load regulation is accomplished when the top of the resistor divider (R1) is connected directly to the output pin of the AMS1117. When so connected, R_P is not multiplied by the divider ratio. For Fixed output version, the top of R1 is internally connected to the output and ground pins can be connected to low side of the load

Figure 2. Best Load Regulation Using Adjustable Output Regulator

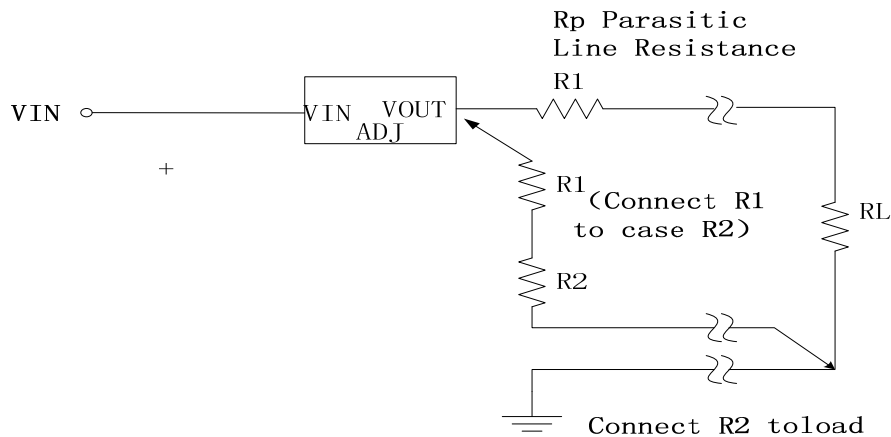

Thermal Protection

AMS1117 has thermal protection which limits junction temperature to 150°C. However, device functionality is only guaranteed to a maximum junction temperature of +125°C. The power dissipation and junction temperature for AMS1117 in DPAK package are given by

$$P_D = (V_{IN} - V_{OUT}) * I_{out}$$
$$T_{JUNCTION} = T_{AMBIENT} + (P_D * \theta_{JA})$$

Note: TJUNCTION must not exceed 125°C

Thermal Consideration

The AMS1117 series contain thermal limiting circuitry designed to protect itself from over-temperature conditions. Even for normal load conditions, maximum junction temperature ratings must not be exceeded. As mention in thermal protection section, we need to consider all sources of thermal resistance between junction and ambient. It includes junction-to-case, case-to-heat-sink interface, and heat sink thermal resistance itself.

Junction-to-case thermal resistance is specified from the IC junction to the bottom of the case directly below the die. Proper mounting is required to ensure the best possible thermal flow from this area of the package to the heat sink. The case of all devices in this series is electrically connected to the output. Therefore, if the case of the device must be electrically isolated, a thermally conductive spacer is recomme

PACKAGE DESCRIPTION

SOT-223 PACKAGE OUTLINE DIMENSIONS

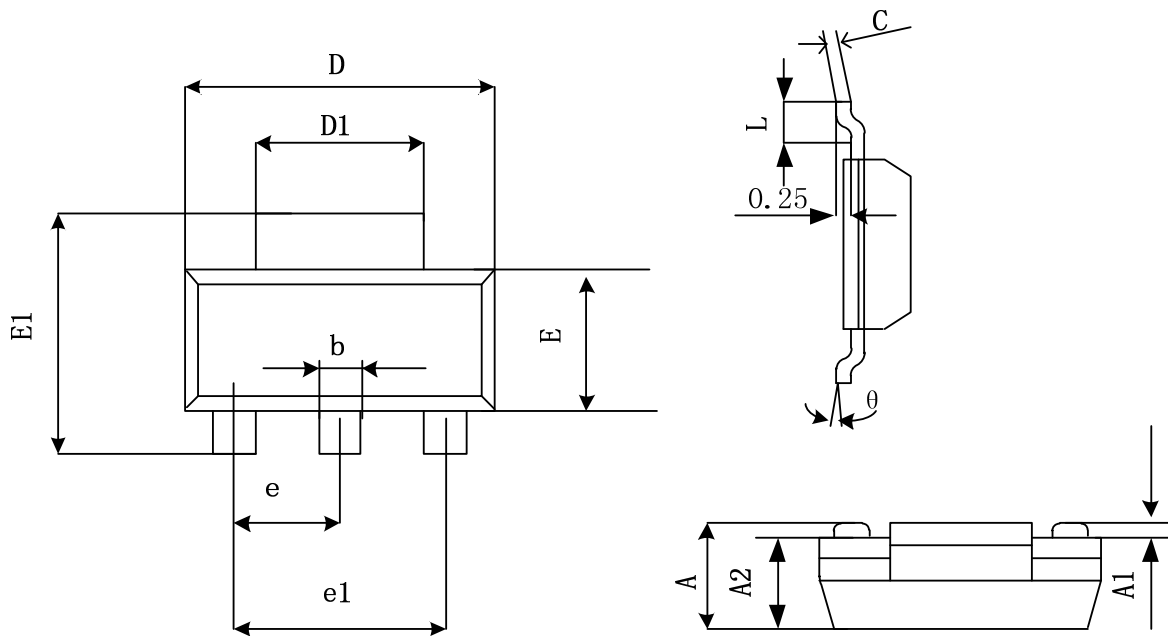

| Symbol | Dimensions In Millimeters | | Dimensions In Inches | |
|--------|---------------------------|-------|----------------------|-------|
| | Min | Max | Min | Max |
| A | 1.520 | 1.800 | 0.060 | 0.071 |
| A1 | 0.020 | 0.130 | 0.001 | 0.005 |
| A2 | 1.500 | 1.700 | 0.059 | 0.067 |
| b | 0.660 | 0.840 | 0.026 | 0.033 |
| c | 0.230 | 0.350 | 0.009 | 0.014 |
| D | 6.450 | 6.850 | 0.254 | 0.270 |
| D1 | 2.900 | 3.000 | 0.114 | 0.122 |
| E | 3.450 | 3.850 | 0.136 | 0.152 |
| E1 | 6.830 | 7.070 | 0.269 | 0.278 |
| e | 2.300 (BSC) | | 0.091(BSC) | |
| e1 | 4.500 | 4.700 | 0.177 | 0.185 |
| L | 0.900 | 1.150 | 0.035 | 0.045 |
| θ | 0° | 10° | 0° | 10 |

TO-252-2L PACKAGE OUTLINE DIMENSIONS

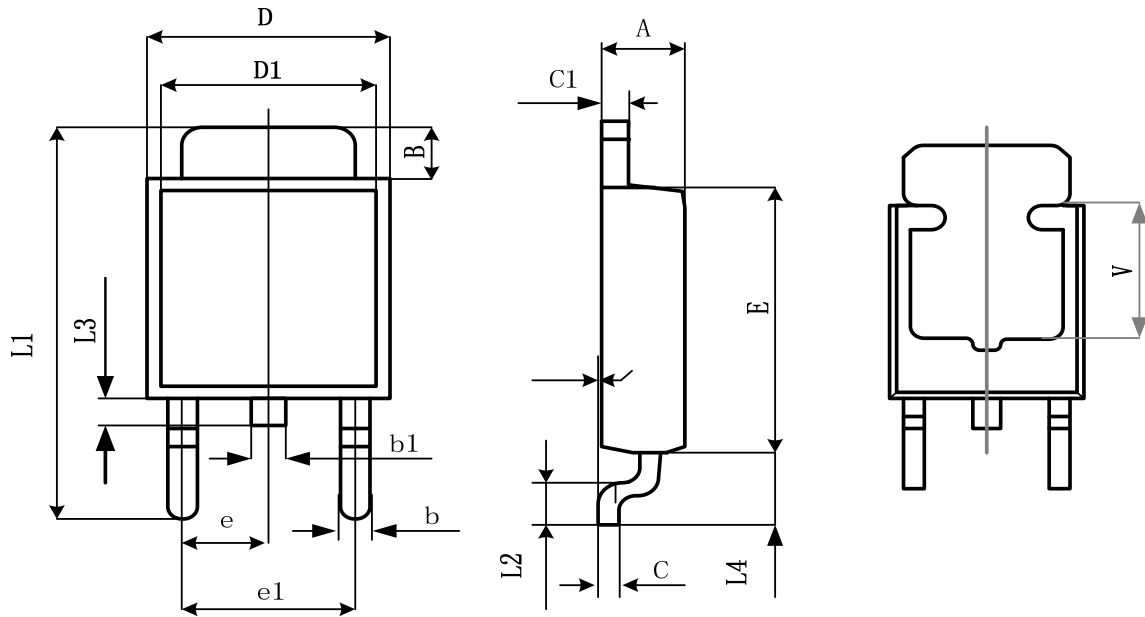

| Symbol | Dimensions In Millimeters | | Dimensions In Inches | |
|--------|---------------------------|-------|----------------------|-------|
| | Min | Max | Min | Max |
| A | 2.200 | 2.400 | 0.087 | 0.094 |
| A1 | 0.000 | 0.127 | 0.000 | 0.005 |
| B | 1.200 | 1.650 | 0.047 | 0.065 |
| b | 0.500 | 0.810 | 0.020 | 0.032 |
| b1 | 0.700 | 0.900 | 0.028 | 0.035 |
| c | 0.460 | 0.580 | 0.018 | 0.023 |
| c1 | 0.430 | 0.580 | 0.014 | 0.023 |
| D | 6.350 | 6.700 | 0.250 | 0.264 |
| D1 | 5.200 | 5.400 | 0.205 | 0.213 |
| E | 5.400 | 6.200 | 0.213 | 0.244 |
| e | 2.300TYP | | 0.0901TYP | |
| e1 | 4.500 | 4.700 | 0.177 | 0.185 |
| L1 | 9.500 | 9.900 | 0.374 | 0.390 |
| L2 | 0.950 | 1.600 | 0.037 | 0.063 |
| L3 | 0.700 | 1.100 | 0.028 | 0.043 |
| L4 | 2.550 | 2.900 | 0.100 | 0.114 |
| V | 3.80REF | | 0.150REF | |

SOT89 PACKAGE OUTLINE DIMENSIONS

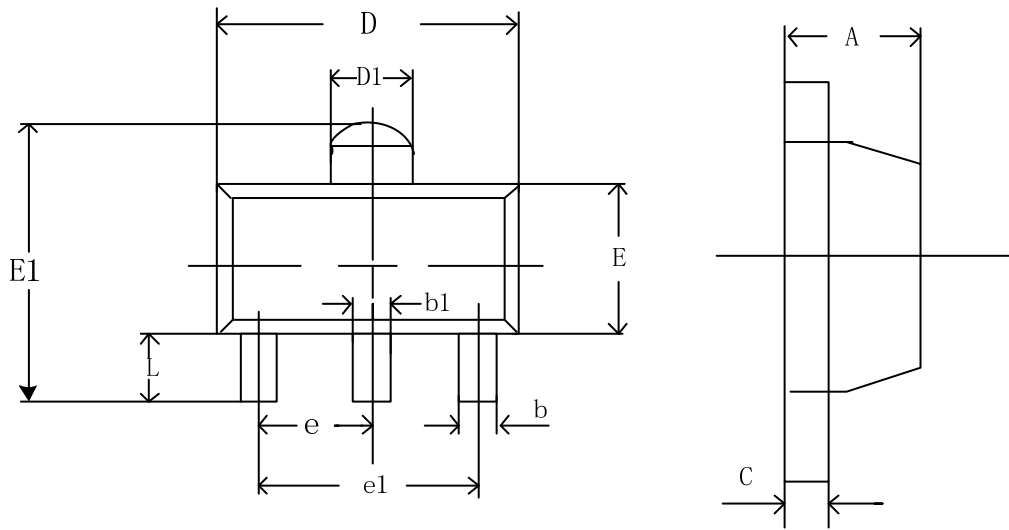

| Symbol | Dimensions In Millimeters | | Dimensions In Inches | |
|--------|---------------------------|-------|----------------------|-------|
| | Min | Max | Min | Max |
| A | 1.400 | 1.600 | 0.055 | 0.063 |
| b | 0.350 | 0.520 | 0.013 | 0.197 |
| b1 | 0.400 | 0.580 | 0.016 | 0.023 |
| c | 0.350 | 0.450 | 0.014 | 0.018 |
| D | 4.400 | 4.600 | 0.173 | 0.181 |
| D1 | 1.550 | 1.750 | 0.061 | 0.069 |
| E | 2.350 | 2.600 | 0.091 | 0.102 |
| E1 | 3.720 | 4.530 | 0.146 | 0.178 |
| e | 1.500TYP | | 0.060TYP | |
| e1 | 3.000TYP | | 0.118TYP | |
| L | 0.820 | 1.100 | 0.032 | 0.047 |