



SGM42505/6/7

7.5V@1.5A DC Motor/Coil Drivers

GENERAL DESCRIPTION

SGM42505/6/7 are bridge-tie drivers designed for actuating motors and coils bi-directionally. They translate logic level input waves to power driving outputs to motors or coils, for different spinning or moving directions. Internal over-current (OC) and under-voltage protection (UV) circuits, together with over-temperature (OT) circuit prevent the circuit from over stress condition, while an alert output report simplifies stalling sensing, which is useful feature to most kinds of applications.

The SGM42505/6 are available in Green SC70-6 package. The SGM42507 is available in Green TSOT-23-6 package. They operate over an ambient temperature range of -40°C to +85°C.

APPLICATIONS

Utility Meters, Robots, Solenoid

FEATURES

- Compact Size and Smart Protection
- Reliable Signaling to High EM Interference
- Rotator Stalling and Magnetic Force Holding
- Support Fast Decay and Slow Decay Model
- Internal Stalling Sense
- Internal OC/UV/OT Protections
 - ◆ Over-Current Threshold Options: 0.45A/0.75A/1.5A
 - ◆ Under-Voltage Protect Threshold Options: 1.75V/2.8V/3.6V
- 7.5V SGM42505/6/7 for Circuit Powered by:
 - ◆ 1 Li+/Poly Cell
 - ◆ 2/3/4 Dry Cells
 - ◆ 1/2 LiSOCl₂ Cell(s)
- -40°C to +85°C Operating Temperature Range
- SGM42505/6 are Available in Green SC70-6 Package
- SGM42507 is Available in Green TSOT-23-6 Package

TYPICAL APPLICATION

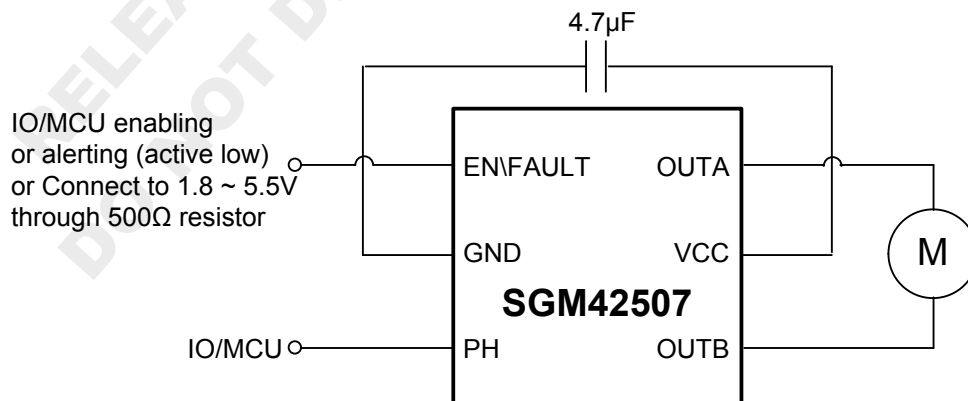

PACKAGE/ORDERING INFORMATION

MODEL	PACKAGE DESCRIPTION	SPECIFIED TEMPERATURE RANGE	ORDERING NUMBER	PACKAGE MARKING	PACKING OPTION
SGM42505A	SC70-6	-40°C to +85°C	SGM42505AYC6G/TR	GS5XX	Tape and Reel, 3000
SGM42505B	SC70-6	-40°C to +85°C	SGM42505BYC6G/TR	GS6XX	Tape and Reel, 3000
SGM42505C	SC70-6	-40°C to +85°C	SGM42505CYC6G/TR	GS7XX	Tape and Reel, 3000
SGM42506A	SC70-6	-40°C to +85°C	SGM42506AYC6G/TR	GS8XX	Tape and Reel, 3000
SGM42506B	SC70-6	-40°C to +85°C	SGM42506BYC6G/TR	GS9XX	Tape and Reel, 3000
SGM42506C	SC70-6	-40°C to +85°C	SGM42506CYC6G/TR	GSAXX	Tape and Reel, 3000
SGM42507A	TSOT-23-6	-40°C to +85°C	SGM42507AYTN6G/TR	GM5XX	Tape and Reel, 3000
SGM42507B	TSOT-23-6	-40°C to +85°C	SGM42507BYTN6G/TR	GS0XX	Tape and Reel, 3000
SGM42507C	TSOT-23-6	-40°C to +85°C	SGM42507CYTN6G/TR	GS1XX	Tape and Reel, 3000

NOTE: XX = Date Code.

Green (RoHS & HSF): SG Micro Corp defines "Green" to mean Pb-Free (RoHS compatible) and free of halogen substances. If you have additional comments or questions, please contact your SGMICRO representative directly.

MARKING INFORMATION

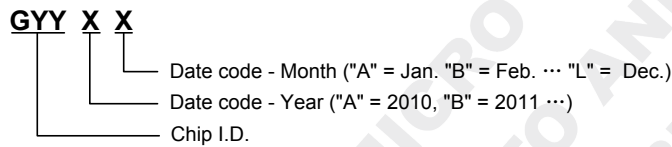

For example: GM5FA (2015, January)

SELECTABLE MODEL

MODEL	OVER-CURRENT PROTECT THRESHOLD (A)	UNDER-VOLTAGE PROTECT THRESHOLD (V)
SGM42505A	0.45	1.75
SGM42505B	0.45	2.8
SGM42505C	0.45	3.6
SGM42506A	0.75	1.75
SGM42506B	0.75	2.8
SGM42506C	0.75	3.6
SGM42507A	1.5	1.75
SGM42507B	1.5	2.8
SGM42507C	1.5	3.6

ABSOLUTE MAXIMUM RATINGS

V_{CC} -0.3V to 7.7V
 Digital Input Pin Voltage Range -0.3V to 6V
 Package Thermal Resistance

SC70-6, θ_{JA}450°C/W
 TSOT-23-6, θ_{JA}250°C/W
 Junction Temperature +150°C
 Storage Temperature Range..... -65°C to +150°C
 Lead Temperature (Soldering, 10s)..... +260°C

RECOMMENDED OPERATING CONDITIONS

V_{CC} -0.3V to 7.5V
 Digital Input Pin Voltage Range..... -0.3V to 5.5V
 Operating Temperature Range..... -40°C to +85°C

OVERSTRESS CAUTION

Stresses beyond those listed may cause permanent damage to the device. Functional operation of the device at these or any other conditions beyond those indicated in the operational section of the specification is not implied. Exposure to absolute maximum rating conditions for extended periods may affect reliability.

ESD SENSITIVITY CAUTION

This integrated circuit can be damaged by ESD if you don't pay attention to ESD protection. SGMICRO recommends that all integrated circuits be handled with appropriate precautions. Failure to observe proper handling and installation procedures can cause damage. ESD damage can range from subtle performance degradation to complete device failure. Precision integrated circuits may be more susceptible to damage because very small parametric changes could cause the device not to meet its published specifications.

DISCLAIMER

SG Micro Corp reserves the right to make any change in circuit design, specification or other related things if necessary without notice at any time.

PIN CONFIGURATIONS

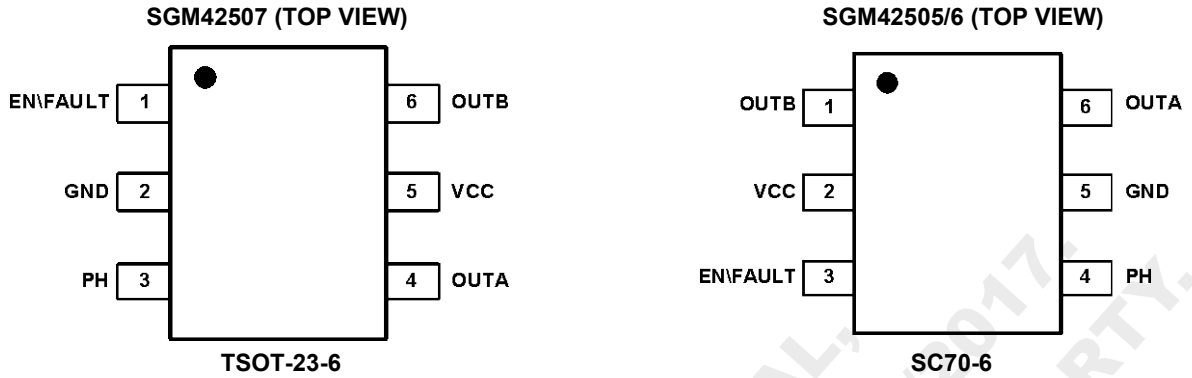

PIN DESCRIPTIONS

PIN		NAME	TYPE	FUNCTION
TSOT-23-6	SC70-6			
1	3	EN\FAULT	I/O	Enable Input or Alert Output ($V_{EN\text{FAULT}} \leq V_{CC}$). Input logic high to enable directional driving, logic low to enter low power dissipation mode and reset all internal logic. Internal pull-down.
2	5	GND	G	Ground.
3	4	PH	I	Direction Input ($V_{PH} \leq V_{CC}$). Logic High for sourcing from OUTA and sinking into OUTB, logic Low for reversely driving. Internal pull-down.
4	6	OUTA	O	Output A of Bridge-Tie Driving Stage.
5	2	VCC	P	Power Input. A 4.7µF (MIN) ceramic bypass capacitor to GND is recommended.
6	1	OUTB	O	Output B of Bridge-Tie Driving Stage.

NOTE: I: Input, O: Output, I/O: Input or Output, G: Ground, P: Power for the circuit.

FUNCTIONAL BLOCK DIAGRAM

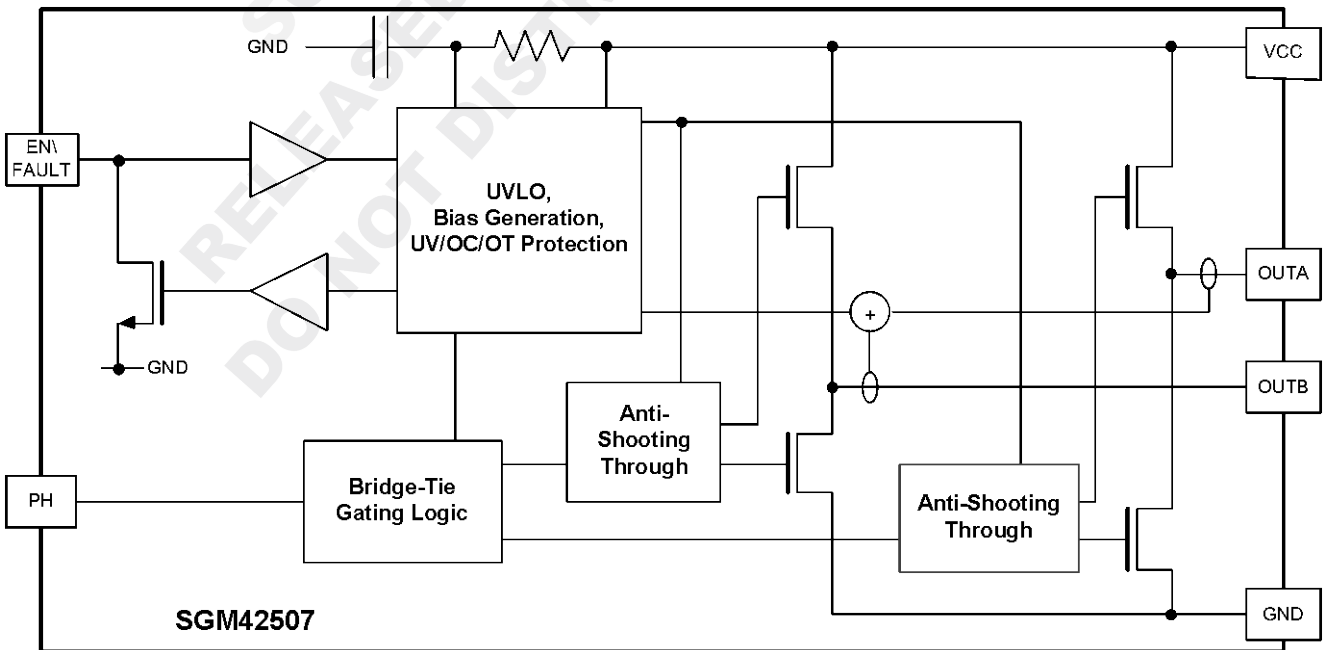

Figure 1. Block Diagram

ELECTRICAL CHARACTERISTICS

(V_{CC} = 5V, EN\FAULT connect to 5V through 500Ω resistor, T_A = +25°C, unless otherwise noted.)

PARAMETER	SYMBOL	CONDITIONS	MIN	TYP	MAX	UNITS
POWER SUPPLIES						
V _{CC} Power Supply Voltage	V _{CC}		1.8		7.5	V
Digital Input Voltage Range (EN\FAULT, PH)	V _{IN}		0		5.5	V
V _{CC} Sleep Mode Supply Current	I _{VCCQ}	V _{CC} = 5V, EN\FAULT = GND, PH = GND		1.3		μA
V _{CC} Under-Voltage Lockout Voltage	V _{UVLO}			1.7		V
V _{CC} Under-Voltage Lockout Voltage Hysteresis	V _{HYS}			100		mV
V _{CC} Under-Voltage Protect Voltage	V _{UVP}	SGM42505A/SGM42506A/SGM42507A		1.75		V
		SGM42505B/SGM42506B/SGM42507B		2.8		
		SGM42505C/SGM42506C/SGM42507C		3.6		
V _{CC} Under-Voltage Protect Voltage Hysteresis	V _{HYS}			100		mV
LOGIC LEVEL INPUTS						
Input Low Voltage	V _{IL}				0.4	V
Input High Voltage	V _{IH}		1.7			V
Input Low Current	I _{IL}			1.0		μA
Input High Weak Pull-Down Current	I _{IH_weak}	Self-Holding Low Inputs		60		uA
Input High Strong Pull-Down Current	I _{IH_strong}	Self-Holding Low Inputs		1.0		mA
Input Deglitch Time	t _{DEG}			300		ns
FAULT OUTPUT (OPEN-DRAIN OUTPUT EN\FAULT)						
Output High-Impedance Leakage Current	I _{OH}			1.0		μA
H-BRIDGE FETS						
HS FET On-Resistance	R _{DS(ON)}	V _{CC} = 5V, I _O = 200mA		410		mΩ
LS FET On-Resistance	R _{DS(ON)}	V _{CC} = 5V, I _O = -200mA		235		mΩ
Off-State Leakage Current	I _{OFF}	V _{OUT} = 0V		1.0		μA
MOTOR DRIVER						
Rise Time	t _R	R _L = 16Ω to GND, 10% to 90% V _{CC}		125		ns
Fall Time	t _F	R _L = 16Ω to V _{CC} , 90% to 10% V _{CC}		155		ns
Propagation Delay INx to OUTx	t _{PROP}			1.0		μs
Dead Time ⁽¹⁾	t _{DEAD}			255		ns
PROTECTION CIRCUITS						
Over-Current Protection Trip Level	I _{OCP}	SGM42505A/B/C		0.45		A
		SGM42506A/B/C		0.75		
		SGM42507A/B/C		1.5		
OCP_H Deglitch Time	t _{DEG_H}			200		μs
OCP_L Deglitch Time	t _{DEG_L}			200		μs
SLEEP MODE						
Enter Sleep Mode Time	t _{SLEEP}			2.0		ms
Startup Time	t _{WAKE}	EN\FAULT Inactive High to H-bridge on		4.0		ms

NOTE: 1. Internal dead time. External implementation is not necessary.

DETAILED DESCRIPTION

H-Bridge Control and Decay Modes

The device has two push-pull stages that drive a bridge-tied load between those stages. When the stages are enabled, input PH selects driving direction into the load, when PH = 1, OUTA is H and OUTB is L, or reversely when PH = 0.

EN\FAULT is a dual function bi-direction input or output. When EN\FAULT is driven by the host externally, If using the EN\FAULT alerting stalling or other protections, the host output driving capability needs to be verified, to assure EN\FAULT sinking capability ($V_{CC} \geq 3V$, $I_{pull_EN\FAULT} = 20mA$) could force it down to low. Or EN\FAULT could connect to 1.8V ~ 5.5V through 500Ω resistor.

EN\FAULT as output port:

When any of over-current protection, under-voltage protection or over-temperature protection occurs, the device sinks current into EN\FAULT, pulls the external driving down to alert the host a protection in action.

The device could read EN\FAULT input Low, only after it is released from a protection action.

EN\FAULT as input port:

EN\FAULT = 1 enables driving load in the direction set by PH input. As shown in the **Table 1 (a, b)**.

EN\FAULT = 0, When EN\FAULT change from 1 to 0, the state of PH is latched at this time, after the current direction of the load is consistent with the PH, then the output stages will tie both OUTA and OUTB to ground. As shown in the **Table 1 (c)**.

EN\FAULT = 0, When EN\FAULT change from 1 to 0, the state of PH is latched at this time, after the current direction of the load is consistent with the PH, then from this moment, after the duration of EN\FAULT = 0 is greater than 2ms, the device will enter low power dissipation mode.

After EN\FAULT logic becomes 0, if the PH logic remain unchanged even once at any time during EN\FAULT = 0, when the device enters or is in low power dissipation mode, the output stages will tie both OUTA and OUTB to ground. As shown in the **Table 1 (d)**.

After EN\FAULT logic becomes 0, if the PH logic changes even once at any time during EN\FAULT = 0, when the device enters or is in low power dissipation mode, the output stages will tie both OUTA and OUTB to high-impedance state. As shown in the **Table 1 (e, f)**.

So, user can choose the output state in the low power dissipation mode, which could be Ground State or High-Impedance State.

Table 1. H-Bridge Logic

STATE	EN\FAULT	PH	OUTA	OUTB	FUNCTION
(a)	1	1	H	L	Forward
(b)	1	0	L	H	Reverse
(c)	0	X	L	L	Slow Decay/Brake
(d)	0	X	L	L	Slow Decay/Brake
(e)	0	1→0	Z	Z	Fast Decay/Coast
(f)	0	0→1	Z	Z	Fast Decay/Coast

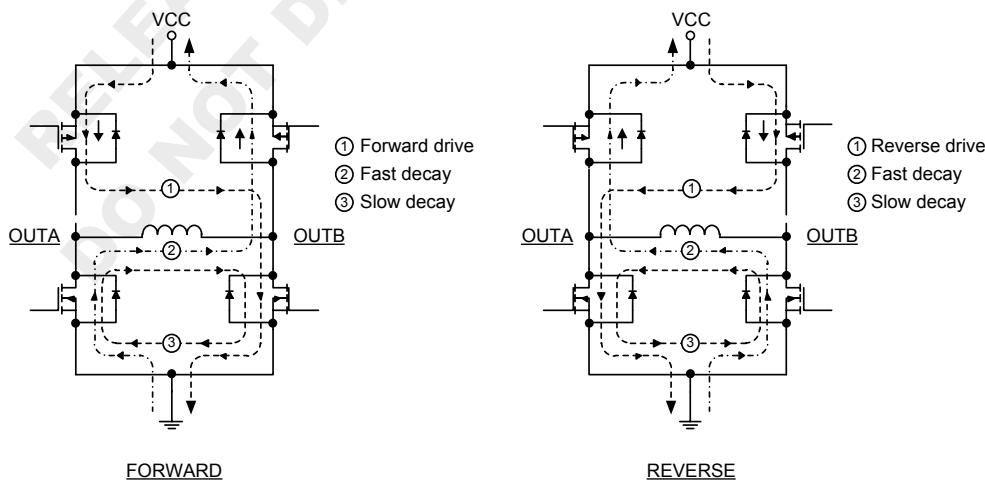

Figure 2. Decay Modes

DETAILED DESCRIPTION (continued)

PWM Motor Drivers

The inputs can be used for PWM control of the motor speed.

Loading PWM signal to PH port, the output stages can realize complementary full scale PWM-Output. As

Table 2. PWM Control of Motor Speed

EN\FAULT	PH	OUTA, OUTB	FUNCTION	PWM MODE
PWM ⁽¹⁾	H	OUTA = PWM, OUTB = GND	Forward PWM Control of Motor Speed	Single Half Scale PWM Mode
PWM ⁽¹⁾	L	OUTA = GND, OUTB = PWM	Reverse PWM Control of Motor Speed	Single Half Scale PWM Mode
H	PWM (D > 50%)	OUTA = +PWM, OUTB = -PWM	Forward PWM Control of Motor Speed	Full Scale PWM Mode
H	PWM (D < 50%)	OUTA = -PWM, OUTB = +PWM	Reverse PWM Control of Motor Speed	Full Scale PWM Mode

NOTE: 1. The duration of EN\FAULT = L must be less than 2ms, in a PWM period. Otherwise the device may enter the low power dissipation mode.

Rotator Stalling and Magnetic Force Holding

When spinning starts or rotator stalls, driving current may go high sharply. The over current protection is designed to alert the starting or stalling situation while provide necessary protection. The device ties both OUTA and OUTB to ground when the current goes high over the protection threshold for over a blanking time, restores driving when the driving current falls below the threshold plus given hysteresis, while asserts an alert by pulling EN\FAULT low during the protection action. The average driving current is kept higher over the threshold current, so the torque or magnetic force is maintained in stalling or starting.

Under-Voltage and Over-Temperature Protections

In any situations, including starting, stalling or function abnormal, if input voltage is down to lower than under voltage threshold or die temperature goes high than the over temperature threshold, the device stops driving and ties both OUTA and OUTB to ground, to prevent the power system from collapse and the die from thermal over stress.

Self-Holding Low Inputs

Both PH and EN\FAULT have a continuous weak pull-down and an intelligent strong pull-down. The strong pull-down is active when input low is recognized and inactive when input high is recognized.

shown in the **Table 2**.

Loading PWM signal to EN\FAULT port, the output stages can realize single half scale PWM-Output, in the direction set by PH. As shown in the **Table 2**.

This assures a known and stable status of input even an input is floating, while keeps low sinking when input high.

FMEA Fault Tolerance

Any of 2 adjacent pins short does not cause damage to this device and its loading.

Table 3. Adjacent Pins Short Effect

SHORT PINS	EFFECT
VCC-PH	Equals to PH = 1. OUTA to OUTB driving is selected, if EN\FAULT input enabling, while all protections function normally.
PH-GND	Equals to PH = 0. OUTB to OUTA driving is selected, if EN\FAULT input enabling, while all protections function normally.
VCC-EN	Equals to EN\FAULT = 1. EN\FAULT = 1 enables driving load in the direction set by PH, while all protections function normally.
EN-GND	Equals to EN\FAULT = 0. The device will tie both OUTA and OUTB to ground, or enter low power dissipation mode.
OUTx-GND	The device will enter the over-current protection mode.
OUTA-OUTB	The device will enter the over-current protection mode.

PACKAGE INFORMATION

PACKAGE OUTLINE DIMENSIONS

TSOT-23-6

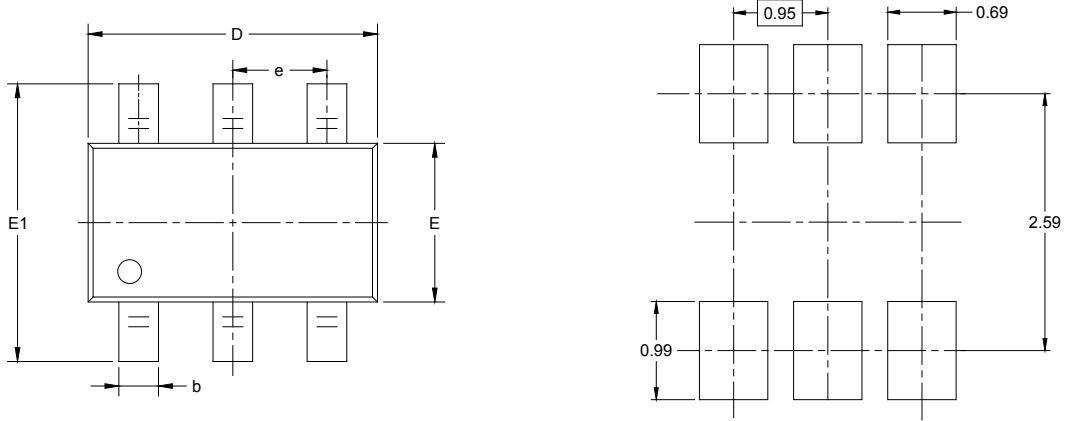

RECOMMENDED LAND PATTERN (Unit: mm)

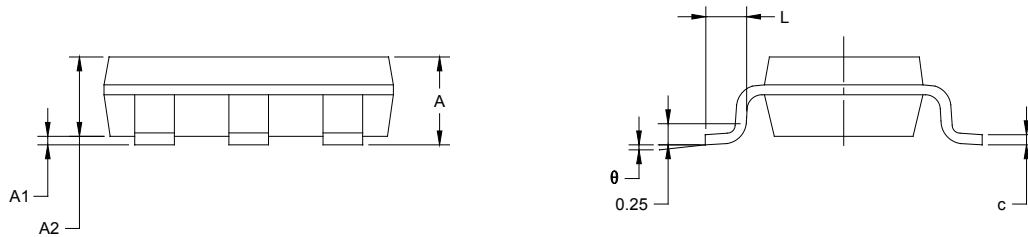

Symbol	Dimensions In Millimeters		Dimensions In Inches	
	MIN	MAX	MIN	MAX
A		1.000		0.043
A1	0.000	0.100	0.000	0.004
A2	0.700	0.900	0.028	0.039
b	0.300	0.500	0.012	0.020
c	0.080	0.200	0.003	0.008
D	2.850	2.950	0.112	0.116
E	1.550	1.650	0.061	0.065
E1	2.650	2.950	0.104	0.116
e	0.950 BSC		0.037 BSC	
L	0.300	0.600	0.012	0.024
θ	0°	8°	0°	8°

PACKAGE OUTLINE DIMENSIONS

SC70-6

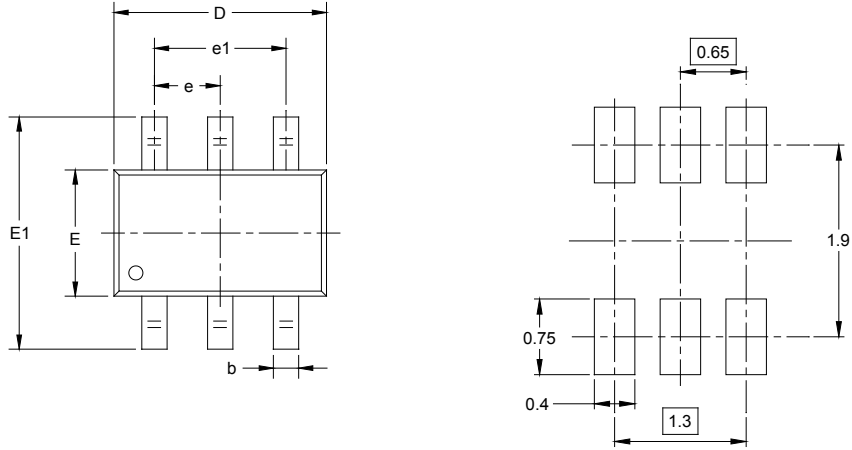

RECOMMENDED LAND PATTERN (Unit: mm)

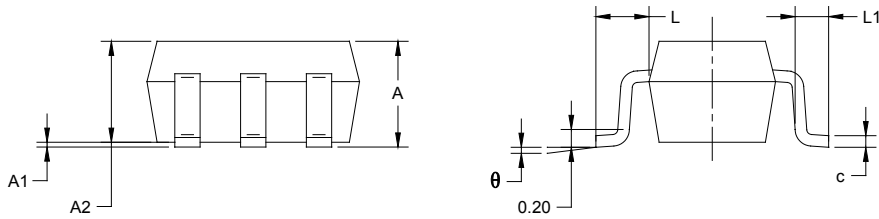

Symbol	Dimensions In Millimeters		Dimensions In Inches	
	MIN	MAX	MIN	MAX
A	0.900	1.100	0.035	0.043
A1	0.000	0.100	0.000	0.004
A2	0.900	1.000	0.035	0.039
b	0.150	0.350	0.006	0.014
c	0.080	0.150	0.003	0.006
D	2.000	2.200	0.079	0.087
E	1.150	1.350	0.045	0.053
E1	2.150	2.450	0.085	0.096
e	0.65 TYP		0.026 TYP	
e1	1.300 BSC		0.051 BSC	
L	0.525 REF		0.021 REF	
L1	0.260	0.460	0.010	0.018
θ	0°	8°	0°	8°

TAPE AND REEL INFORMATION

REEL DIMENSIONS

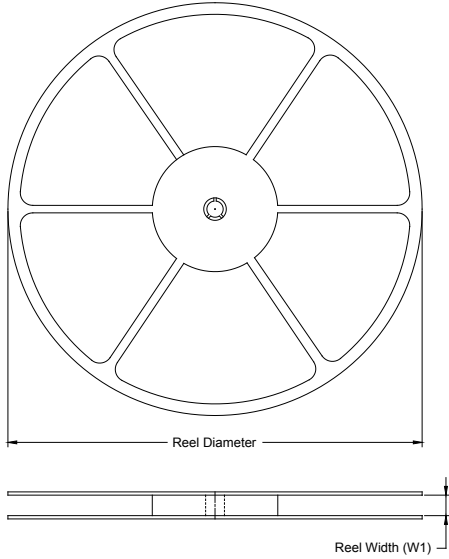

TAPE DIMENSIONS

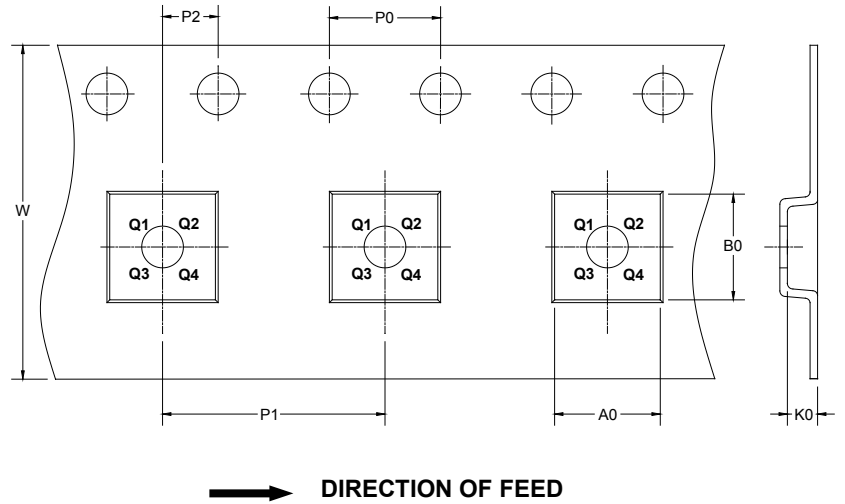

NOTE: The picture is only for reference. Please make the object as the standard.

KEY PARAMETER LIST OF TAPE AND REEL

Package Type	Reel Diameter	Reel Width W1 (mm)	A0 (mm)	B0 (mm)	K0 (mm)	P0 (mm)	P1 (mm)	P2 (mm)	W (mm)	Pin1 Quadrant
TSOT-23-6	7"	9.5	3.20	3.10	1.10	4.0	4.0	2.0	8.0	Q3
SC70-6	7"	9.5	2.40	2.50	1.20	4.0	4.0	2.0	8.0	Q3

000001

PACKAGE INFORMATION

CARTON BOX DIMENSIONS

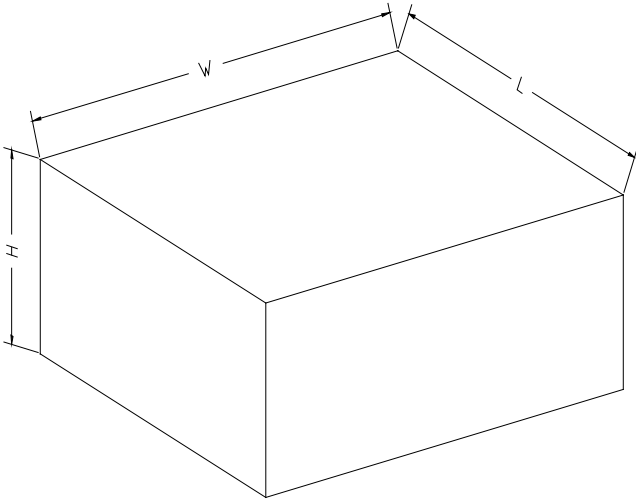

NOTE: The picture is only for reference. Please make the object as the standard.

KEY PARAMETER LIST OF CARTON BOX

Reel Type	Length (mm)	Width (mm)	Height (mm)	Pizza/Carton
7" (Option)	368	227	224	8
7"	442	410	224	18

DD0002