

3-Channel LED Drivers with Multi-mode Auto Charging Indication

FEATURES

- Multi-mode auto charging indication on pin LED0 under low VBAT condition via pin SET1,SET2
 - SET1: breathing (6mA) or always on(3mA)
 - SET2: CHRG =high or low to trigger indication
- 3-channel constant current LED drivers
 - 4-level global maximum current: 5mA,10mA, 15mA, 30mA
 - 16-level individual current for each LED, 4096 color-mixed available
 - 256-level individual PWM dimming
- Automatic breathing light
 - Three independent pattern controllers
 - Individual and sync control selectable
- LED current accuracy: $\pm 3\%$
- LED matching accuracy: $\pm 3\%$
- Low dropout voltage: 50mV
- Low power consumption
 - $I_{STB} < 5\mu A$ in standby mode
- UVLO and OT protection
- Single power supply, 2.5V~5.5V
- 400kHz I²C interface (I²C address: 0x45)
- 2mmx2mm DFN-10L package

GENERAL DESCRIPTION

AW2033 is a three channels constant current LED driver with multi-mode auto charging indication function. The global max output current is 4-level selectable (5mA/10mA/15mA/30mA). The driving current of each LED is 16 levels configurable so as to achieve 4096 color mixing. The 256-level exponential PWM creates fine and smooth dimming effect even in low brightness.

AW2033 provides multi-mode auto charging indication under the condition of low battery voltage. When the voltage of battery is too low, and the I²C interface can't work, the wanted lighting can be output on pin LED0 by triggering pin CHRG. The pin SET1/SET2 select the lighting effect and the active trigger level of pin CHRG respectively.

AW2033 contains three independent pattern controllers. Three LEDs can be controlled to work synchronously or individually according to different applications.

A 400kHz I²C interface is provided with 1.8v~3.3v interface voltage. The tiny 2mmx2mm DFN-10L package occupies very small PCB area.

TYPICAL APPLICATION CIRCUIT

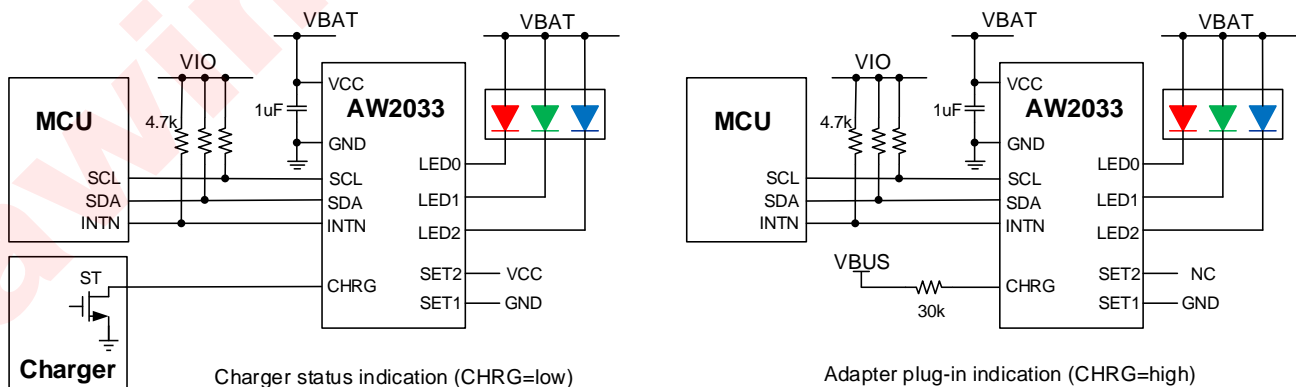

All the trademarks mentioned in the document are the property of their owners.

PIN CONFIGURATION AND TOP MARK

AW2033DNR TOP VIEW

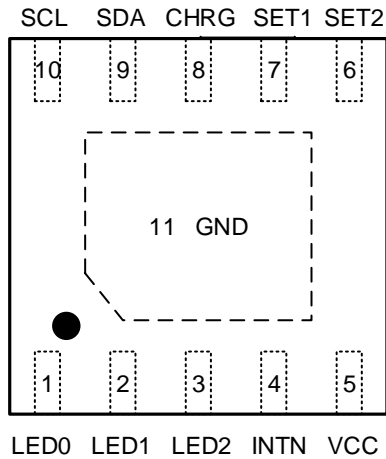

AW2033DNR MARKING



AC33 - AW2033DNR
XXXX - Manufacture date code

PIN DEFINITION

No.	Name	Description
1	LED0	LED0 cathode driver, anode connected to VBAT
2	LED1	LED1 cathode driver, anode connected to VBAT
3	LED2	LED2 cathode driver, anode connected to VBAT
4	INTN	Interrupt output
5	VCC	Power supply (2.5V-5.5V)
6	SET2	Triggering level setting of pin CHRG, internally pulled low. High: triggered by low Low or floating: triggered by high
7	SET1	Charge indicator lighting mode setting, internally pulled high High or floating: Always on (3mA) Low: Breathing effect with 4.5s period, 6mA max current
8	CHRG	Charge indicator triggering input. Internally pulled low when SET2 is low or floated, and internally pulled high when pin SET2 is high.
9	SDA	Serial data I/O for I ² C interface
10	SCL	Serial clock input for I ² C interface
11	GND	Ground

FUNCTIONAL BLOCK DIAGRAM

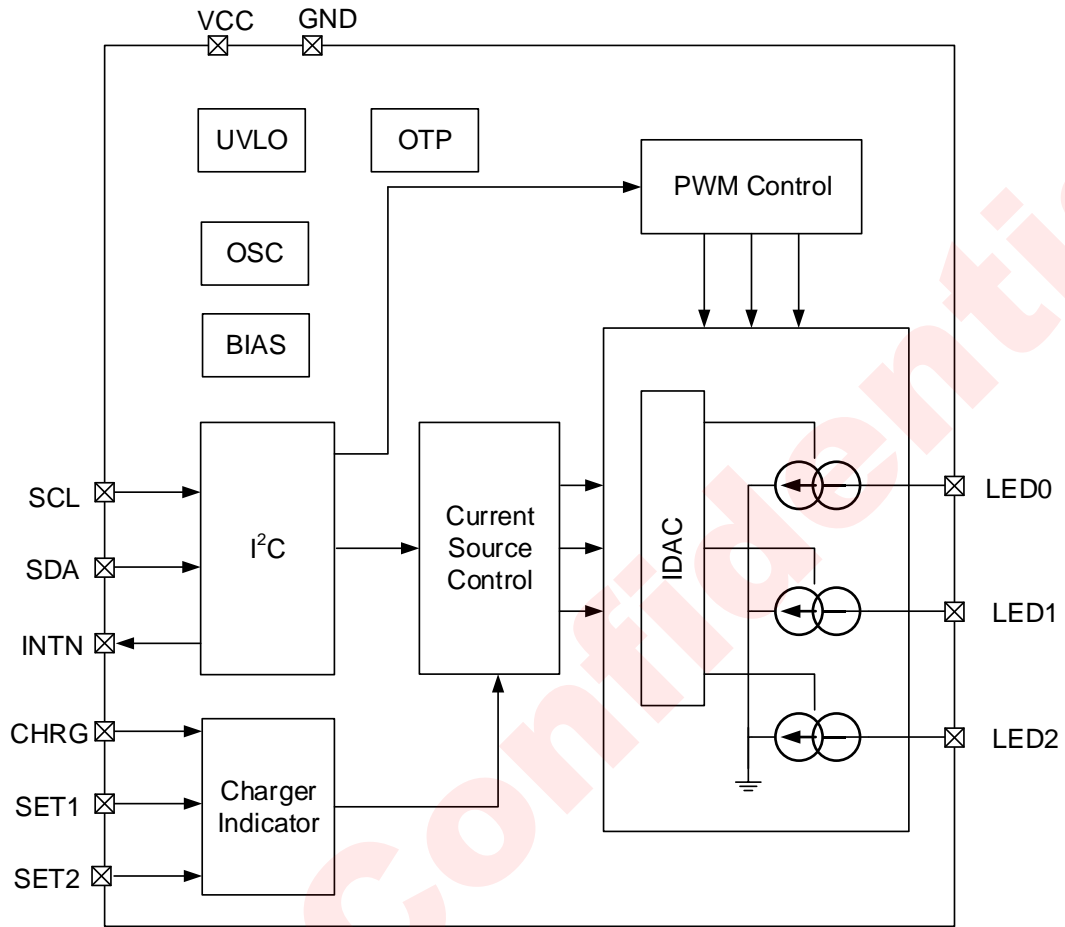

TYPICAL APPLICATION CIRCUITS

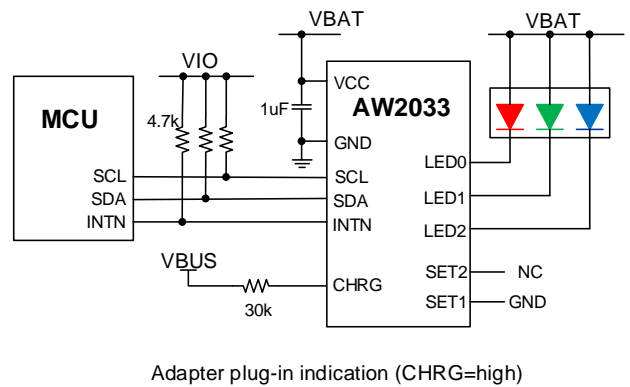
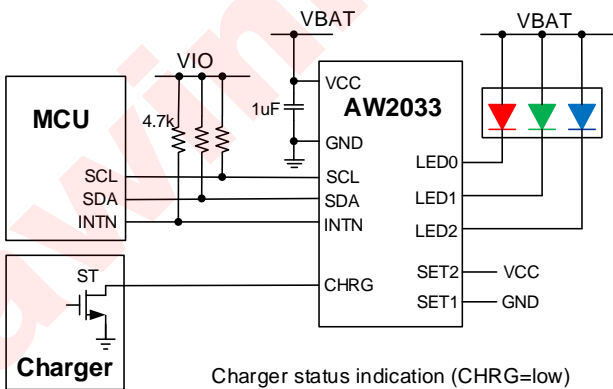

ORDERING INFORMATION

Part Number	Temperature	Package	Marking	MSL Level	ROHS	Delivery Form
AW2033DNR	-40°C~85°C	2mmx2mm DFN-10L	AC33 XXXX	MSL1	ROHS+HF	Tape and Reel 3000pcs/Reel

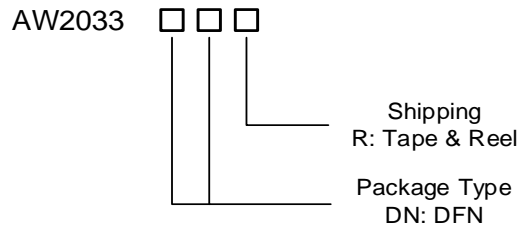

ABSOLUTE MAXIMUM RATINGS (NOTE 1)

PARAMETERS		RANGE
Supply voltage range V_{BAT}		-0.3V to 6.0V
Input voltage range	SCL, SDA,	-0.3V to 6.0V
	CHRG, SET1, SET2	-0.3V to 6.0V
	LED0~LED2	-0.3V to 6.0V
Output voltage range	SDA, INTN	-0.3V to 6.0V
Junction-to-ambient thermal resistance θ_{JA}		45°C/W
Operating free-air temperature range		-40°C to 85°C
Maximum Junction temperature T_{JMAX}		150°C
Storage temperature T_{STG}		-55°C to 125°C
Lead Temperature (Soldering 10 Seconds)		260°C
ESD(NOTE 2)		
HBM		±2000V
MM		±200V
CDM		±2000V
Latch-up		
Test Condition: JEDEC STANDARD NO.78B DECEMBER 2008		350mA

NOTE1: Conditions out of those ranges listed in "absolute maximum ratings" may cause permanent damages to the device. In spite of the limits above, functional operation conditions of the device should within the ranges listed in "recommended operating conditions". Exposure to absolute-maximum-rated conditions for prolonged periods may affect device reliability.

NOTE2: The human body model is a 100pF capacitor discharged through a 1.5kΩ resistor into each pin. Test method: MIL-STD-883G Method 3015.7

ELECTRICAL CHARACTERISTICSV_{BAT}=3.8V, T_A=25°C for typical values (unless otherwise noted)

Symbol	Description	Test Conditions	Min	Typ.	Max	Units
Power Supply						
V _{BAT}	Input operation voltage		2.5		5.5	V
I _{STANDBY}	Current in Standby mode	SCL/SDA=1.8V			5	μA
I _{ACTIVE}	Quiescent Current in Active mode	GCR1.CHIPEN=1 all LED off			100	μA
V _{POR}	Power on reset voltage			1.25		V
V _{UVLO}	UVLO Voltage	GCR2.UVTH[1:0]=00		2		V
T _{OTP}	Over temperature threshold			140		°C
T _{HYS}	Over temperature hysteresis			20		°C
F _{OSC}	Oscillator Frequency		-5%	1.024	+5%	MHz
LED Driver						
I _{ACC}	Current accuracy	I _{LED} =15mA	-3%		+3%	%
I _{MATCH}	Matching accuracy	I _{LED} =15mA	-3%		+3%	%
V _{DROP}	Dropout voltage	I _{LED} =15mA		50	100	mV
F _{PWM}	PWM frequency	LCTR.FREQ=0	-5%	250	+5%	Hz
Digital Logical Interface						
V _{IL}	Logic input low level	SDA,SCL			0.4	V
		CHRG, SET1,SET2			0.4	
V _{IH}	Logic input high level	SDA,SCL	1.3			V
		CHRG, SET1,SET2	V _{CC} -0.2			
I _{IL}	Low level input current	SDA,SCL		5		nA
I _{IH}	High level input current	SDA,SCL		5		nA

V _{OL}	Logic output low level	SDA, INTN, I _{OUT} =3mA			0.4	V
I _L	Output leakage current	SDA, INTN open drain			1	nA

I²C INTERFACE TIMING

Parameter Name		Min	Typ.	Max	Units
F _{SCL}	Interface Clock frequency			400	kHz
T _{DEGLITCH}	Deglitch time	SCL	200		ns
		SDA	250		ns
T _{HD:STA}	(Repeat-start) Start condition hold time	0.6			μs
T _{LOW}	Low level width of SCL	1.3			μs
T _{HIGH}	High level width of SCL	0.6			μs
T _{SU:STA}	(Repeat-start) Start condition setup time	0.6			μs
T _{HD:DAT}	Data hold time	0			μs
T _{SU:DAT}	Data setup time	0.1			μs
T _R	Rising time of SDA and SCL			0.3	μs
T _F	Falling time of SDA and SCL			0.3	μs
T _{SU:STO}	Stop condition setup time	0.6			μs
T _{BUF}	Time between start and stop condition	1.3			μs

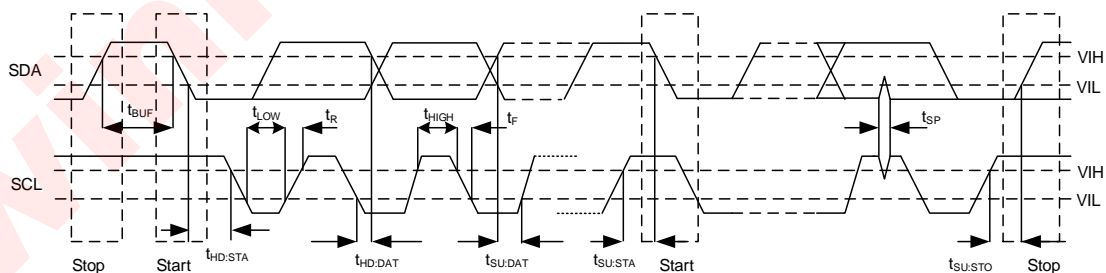

Figure 1 Timing of I²C Interface Signals

FUNCTIONAL DESCRIPTION

POWER ON RESET

When the supply voltage VBAT of AW2033 drops below a predefined voltage V_{POR} (1.25V), the device generates a reset signal to perform a power-on reset operation, which will reset all control circuits and configuration registers.

The status bit ISR.PUIS (register: 0x02 bit4) will be set to 1 when power-on reset operation occurs, which will be cleared by a read operation of ISR register. Usually the ISR.PUIS bit can be used to check whether an unexpected power-on event has taken place.

OPERATING MODE

In AW2033, there are two work modes available: Standby and Active mode.

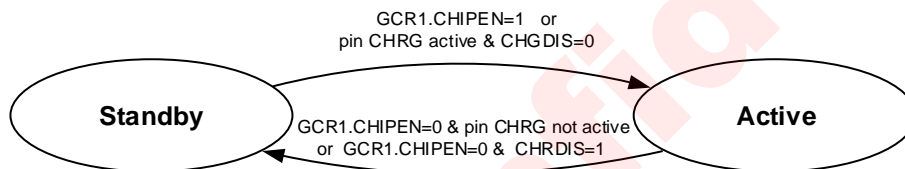

Figure 2 AW2033 operating modes transition

STANDBY MODE

AW2033 enters into standby mode when pin CHRГ is not activated and GCR1.CHIPEN become 0 in active mode.

In standby mode, only part of internal circuit work. The I²C interface is accessible, but only registers RSTR and GCR1 can be written, the internal OSC keep closed and there is not internal clock. The current consumption is less than 5 μ A.

ACTIVE MODE

When bit CHIPEN of GCR1 register is set to 1 or CHRГ is activated in standby mode, the device enters into active mode.

In active mode, the internal OSC works to provide clock signal. User can configure the device to produce the specified breath lighting effects in pattern mode or turn any LED on or off directly.

SOFTWARE RESET

Writing 0x55 to register RSTR (register: 0x00) via I²C interface will reset the device, including all functional circuits and configuration registers.

UNDER VOLTAGE LOCK OUT (UVLO)

The voltage on pin VBAT is monitored internally by the AW2033. When voltage of V_{CC} drops below predefined threshold by bit GCR2.UVTH (2.0v typically), the UVLOIS flag bit in ISR register is set to "1". After a read, the flag register can be cleared.

When UVLO condition is met, the bit CHIPEN in register GCR1 will be cleared, and the device return to standby state. If V_{CC} rises above the threshold and GCR1.CHIPEN bit is set to "1", the device will enter into active mode again.

If the UVDIS bit in register GCR2 is set to "1", the internal UVLO monitor is disabled. The default value of the UVDIS bit is "0".

If the DUVP bit in register GCR2 is set to "1", the UVLO protection function is closed, the device keeps working even though UVLO state is detected. The default value of the DUVP bit is "0".

OVER TEMPERATURE PROTECTION

When the device reaches 140°C, the over-temperature protection be activated, and the OTPIS flag bit in register ISR is set to "1", and after a read, the flag register can be cleared.

When OTP condition is met, the bit CHIPEN in register GCR1 will be cleared, and the device will be forced to standby state. Once the temperature of the device drops below 120°C, and GCR1.CHIPEN bit is set to "1", the device will enter into active mode again.

If the OTDIS bit in register GCR2 is set to "1", the OTP function is disabled. The default value of the OTDIS bit is "0".

If the DOTP bit in register GCR2 is set to "1", the OTP protection function is closed, the device keeps working even though over-temperature condition is detected. The default value of the DOTP bit is "0".

I²C INTERFACE

AW2033 supports the I²C serial bus and data transmission protocol in fast mode at 400 kHz. AW2033 operates as a slave on the I²C bus. Connections to the bus are made via the open-drain I/O pins SCL and SDA. The pull-up resistor can be selected in the range of 1k~10kΩ and the typical value is 4.7kΩ. AW2033 can support different high level (1.8V~3.3V) of this I²C interface.

DEVICE ADDRESS

The I²C device address (7-bit) of AW2033 is 0x45, followed by the R/W bit (Read=1/Write=0).

DATA VALIDATION

When SCL is high level, SDA level must be constant. SDA can be changed only when SCL is low level.

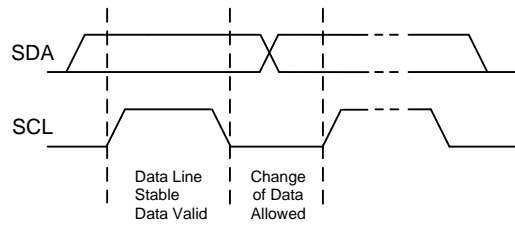

Figure 3 Data Validation Diagram

I²C START/STOP

I²C start: SDA changes from high level to low level when SCL is high level.

I²C stop: SDA changes from low level to high level when SCL is high level.

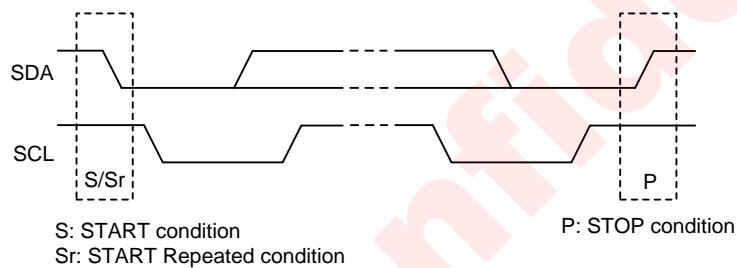

Figure 4 I²C Start/Stop Condition Timing

ACK (ACKNOWLEDGEMENT)

ACK means the successful transfer of I²C bus data. After master sends 8bits data, SDA must be released; SDA is pulled to GND by slave device when slave acknowledges.

When master reads, slave device sends 8bit data, releases the SDA and waits for ACK from master. If ACK is send and I²C stop is not send by master, slave device sends the next data. If ACK is not send by master, slave device stops to send data and waits for I²C stop.

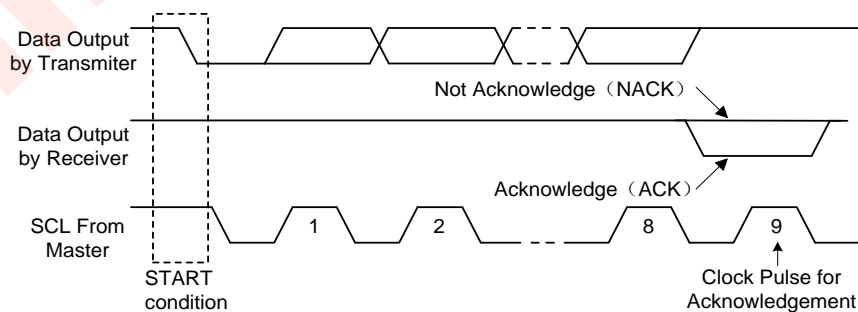

Figure 5 I²C ACK Timing

WRITE CYCLE

One data bit is transferred during each clock pulse. Data is sampled during the high state of the serial clock (SCL). Consequently, throughout the clock's high period, the data should remain stable. Any changes on the SDA line during the high state of the SCL and in the middle of a transaction, aborts the current transaction. New data should be sent during the low SCL state. This protocol allows a single data line to transfer both command/control information and data using the synchronous serial clock.

Each data transaction is composed of a Start Condition, a number of byte transfers (set by the software) and a Stop Condition to terminate the transaction. Every byte written to the SDA bus must be 8 bits long and is transferred with the most significant bit first. After each byte, an Acknowledge signal must follow.

In a write process, the following steps should be followed:

- Master device generates START condition. The "START" signal is generated by lowering the SDA signal while the SCL signal is high.
- Master device sends slave address (7-bit) and the data direction bit ($r/w = 0$).
- Slave device sends acknowledge signal if the slave address is correct.
- Master sends control register address (8-bit)
- Slave sends acknowledge signal
- Master sends data byte to be written to the addressed register
- Slave sends acknowledge signal
- If master will send further data bytes the control register address will be incremented by one after acknowledge signal (repeat step f,g)
- Master generates STOP condition to indicate write cycle end



Figure 6 I²C Write Byte Cycle

READ CYCLE

In a read cycle, the following steps should be followed:

- Master device generates START condition
- Master device sends slave address (7-bit) and the data direction bit ($r/w = 0$).
- Slave device sends acknowledge signal if the slave address is correct.
- Master sends control register address (8-bit)
- Slave sends acknowledge signal
- Master generates STOP condition followed with START condition or REPEAT START condition
- Master device sends slave address (7-bit) and the data direction bit ($r/w = 1$).
- Slave device sends acknowledge signal if the slave address is correct.

- i) Slave sends data byte from addressed register.
- j) If the master device sends acknowledge signal, the slave device will increase the control register address by one, then send the next data from the new addressed register.
- k) If the master device generates STOP condition, the read cycle is ended.

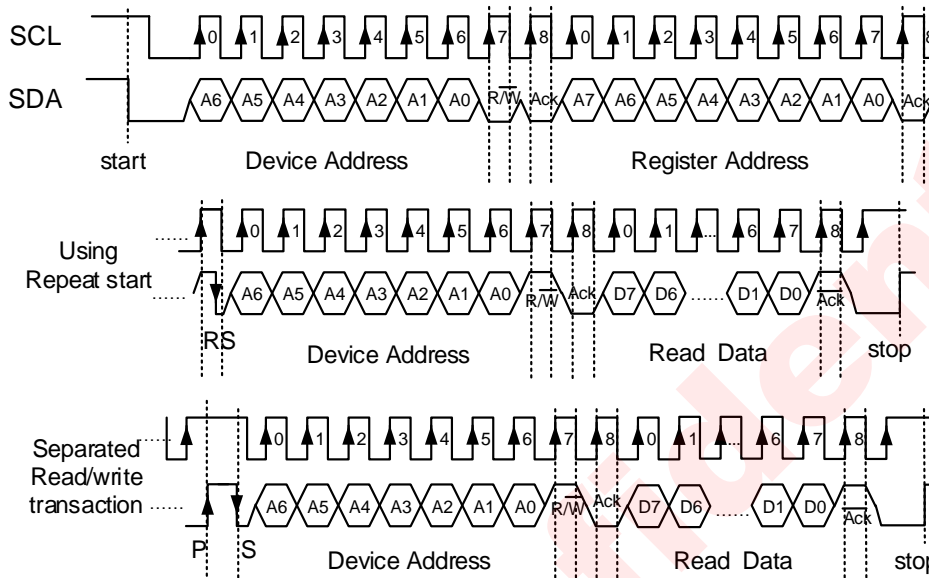

Figure 7 I²C Read Byte Cycle

LED DRIVER

AW2033 has 3 LED drivers to drive one RGB LED or three single-color LEDs. Each LED is driven by common-anode mode constant current source with duty cycle controlled by PWM. Both current and PWM level can be configured via I²C interface.

LED CURRENT

Globally, the maximum output current for three LEDs is 4-level selectable among 5mA, 10mA, 15mA and 30mA via register GCR2.IMAX (register: 0x04). In general, GCR2.IMAX is used to set the max brightness of LED output.

For each LED, there is 16 current levels configurable via 4-bit register groups LCFGx.CUR (x=0~2). So in RGB application it is possible to combine into 16x16x16 color-mixing schemes totally.

PWM DIMMING CONTROL

The LED output current source is gated by exponent 256-level PWM signal to create better dimming effect. The registers PWMx (address 0x34, 0x35, 0x36) define 8-bit PWM level for each LED.

When register PWMx being modified or working in PATTERN mode, the smooth transition effect is available by continuously adjusting PWM duty. The slope of ramp up/down, are separately set via configuring the bit4~bit7 in pattern registers LEDxT0/1 (x=0~2).

The ramping curve can be configured to be linear and exponential by setting bit3 (EXP) in register LCTR

(address 0x30).

LED CONTROL

All LEDs in AW2033 can be independently turned on or off via setting bit LEx (x=0~2) of register LCTR .

- LCTR.LEx=0, LEDx is switched off.
- LCTR.LEx=1, LEDx is switched on.

PATTERN MODE

When register bit LCFGx.MD (address 0x31, 0x32, 0x33, x=0~2) is set to "1", the corresponding LEDx operates in pattern mode.

In this mode, the LEDx is controlled by internal pattern controller to produce breathing lighting effect with user-defined timing parameter. In AW2033, each LED has an independent pattern controller with respective pattern parameter configuration register, and work independently.

The waveform of a breathing pattern is shown in the diagram below. The parameter T0~T4 define 4 key primary time in a complete breathing period. T0 is the delay time before pattern starting, T1~T4 composite a breathing cycle, which denote the rise-time, on-time, fall-time and off- time respectively.

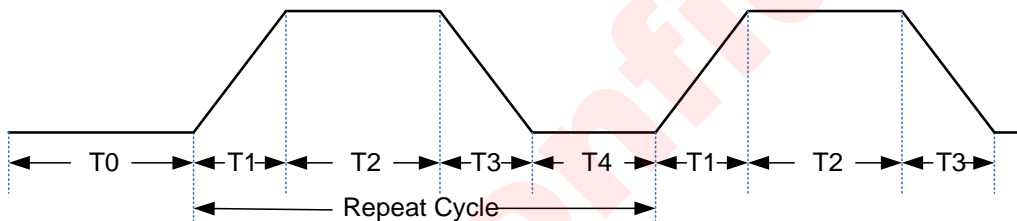

Figure 8 LED breath timing in pattern mode

The repeat times of pattern is configured by bit0~3 (REPEAT) in register LEDxT2(x=0~2). A pattern can repeat for 1 to 15 times if LEDxT2.REPEAT is not "0000", or loop continuously if LEDxT2.REPEAT is "0000".

After defined times of pattern repeat is finished, the status bit ISR.LISx (x=0~2, address 0x02) will be set to "1" automatically, which only can be cleared after reading register ISR via I²C.

In pattern mode, each channel can be configured independently. The breath effect will start once LEDxT2 (x=0~2) is written. If user wants to sync the three channel start at the same time, please follow the following steps:

- a) Set LCTR to 00h
- b) Set LCFGx.MD to "0"
- c) Configure LEDxT0, LEDxT1, LEDxT2 for parameters T0~T4, repeat time .
- d) Set LCFGx.MD to "1"
- e) Set LCTR to 07h

MANUAL CONTROL MODE

When control bit LCFGx.MD (register: 0x31, 0x32, 0x33 bit4) is set to 0, the corresponding LEDx(x=0~2) is work in manual control mode.

In manual control mode, the pattern controller is disable and the LED is directly controlled by setting current/

PWM level register via I²C interface.

In manual control mode, smooth dimming is supported. If LCFGx.FO (address 0x31, 0x32, 0x33, bit6) is set to 1, automatic fade-out is enabled. If LCFGx.FI (register: 0x31, 0x32, 0x33 bit5) is set to 1, automatic fade-in is enabled. If a new value is set on register PWMx when LCFGx.FI and/or LCFGx.FO is set, the brightness of LED output ramp up/down smoothly, with its transition time defined by parameter T1, T3 sourced from corresponding pattern configuration (LEDxT1 and LEDxT2).

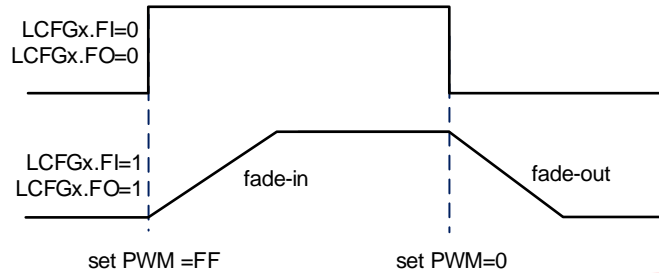

Figure 9 Manual Control Mode

SYNC CONTROL MODE

In order to simplify configuration and control in the case of all LEDs synchronously dimming, especially in application of RGB LED, the AW2033 can be configured to work on sync control mode.

When LCFG0.SYNC is set to 1, the device works in sync control mode. In this mode, user can control all LEDs to turn on, turn off, or output breathing lighting synchronously only by controlling LED0.

In sync control mode, the output currents of all LEDs are still defined via register LCFGx.CUR individually, but their PWM levels of LED1, LED2 are both sourced from LED0, the setting of register PWM1, PWM2 are ignored. The control bit LCFG0.MD defines operating mode globally for all LEDs. If CFG0.MD is 0, manual mode is selected for all LEDs, user can set all LEDs on or off by simply setting register PWM0, and fade-in or fade-out effect are selected by bit LCFG0.FI and LCFG0.FO. If register LCFG0.MD is set 1, all LEDs work in pattern mode, user only need to configured and control the pattern of LED0.

AUTO CHARGING INDICATION

In application of mobile phone, when battery voltage is too low and the PMU cannot work, the LED driver cannot be controlled by application processor via I²C interface. In this case, extra LED control circuit is necessary to be built in for charging status indication.

AW2033 provides the auto charging indication function for low battery voltage application. When the external USB power is inserts to phone, and the pin CHRG is activated, AW2033 will enter active state automatically. The predefined pattern output only on pin LED0, the LED1 and LED2 keep off status.

The charge indicator mode is set by pin SET1.

When pin SET1 is high or floating, the charge indication is LED0 always on with 3mA current.

When pin SET1 is low, the charge indication is breathing lighting with 4.5s period, 6mA max current.

The trigger level on pin CHRG for auto charging indication is set by pin SET2.

When pin SET2 is low or floating, the pin CHRG is active high.

When pin SET2 is high, the pin CHRG is active low.

When SET1 and SET2 are both low, the charge indication pattern parameter is showed in figure below. The maximum current is 6mA, breathing period is about 4.5s. Once the CHRG pin goes low, the device return to standby state again and stops LED0 output.

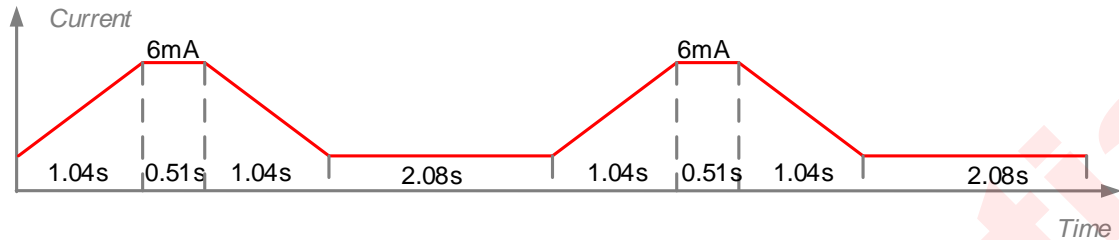

Figure 10 Auto Charging Indication Pattern Parameter

The auto charging indication function should be closed by configured register GCR1.CHGDIS (register: 0x01 bit2) to 1 when the processor is able to configure AW2033 via I²C interface, then the lighting effects will have no relation with the CHRG status.

When special charger IC is used, pin CHRG is recommend to be connected to status pin of charger IC, the pin SET2 connected to high, the lighting output on pin LED0 indicates the real battery charging status controlled directly by charger IC.

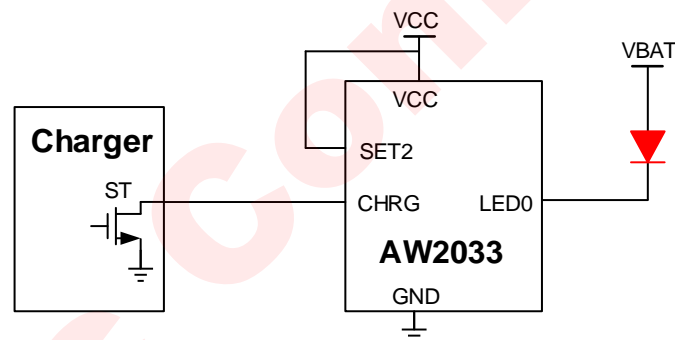

Figure 11 Real Charging Status Indication in special charger IC application

When no charger IC is applied, and battery charging is managed by PMU, no real charging status signal can be adapted, so the LED0 status can only indicate whether the USB power is plugged in or not.

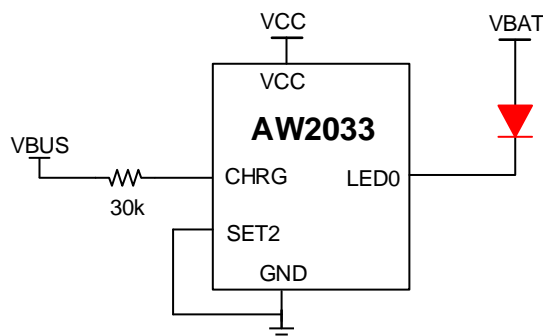

Figure 12 USB power Insertion status Indication in PMU-controlled charging application

REGISTER DESCRIPTION**REGISTER LIST**

Addr	Name	W/R	Bit7	Bit 6	Bit 5	Bit 4	Bit 3	Bit 2	Bit 1	Bit 0
00h	RSTR	WR	0	0	0	0	1	0	0	1
01h	GCR1	WR	LIE2	LIE1	LIE0		UVLOIE	OTPIE	CHGDIS	CHIPEN
02h	ISR	R	LIS2	LIS1	LIS0	PUIS	UVLOIS	OTPIS	-	-
03h	PATST	R	0	0	0	0	0	ST2	ST1	ST0
04h	GCR2	WR	DUVP	DOTP	UVDIS	OTDIS	UVTH		IMAX	
30h	LCTR	WR	-	-	FREQ	-	EXP	LE2	LE1	LE0
31h	LCFG0	WR	SYNC	FO	FI	MD	CUR			
32h	LCFG1	WR	-	FO	FI	MD	CUR			
33h	LCFG2	WR	-	FO	FI	MD	CUR			
34h	PWM0	WR	PWM							
35h	PWM1	WR	PWM							
36h	PWM2	WR	PWM							
37h	LED0T0	WR	T1				T2			
38h	LED0T1	WR	T3				T4			
39h	LED0T2	WR	T0				REPEAT			
3Ah	LED1T0	WR	T1				T2			
3Bh	LED1T1	WR	T3				T4			
3Ch	LED1T2	WR	T0				REPEAT			
3Dh	LED2T0	WR	T1				T2			
3Eh	LED2T1	WR	T3				T4			
3Fh	LED2T2	WR	T0				REPEAT			

DETAILED REGISTER DESCRIPTION**RSTR, Chip ID and Software Reset Register**

Address: 0x00, R/W, default: 0x09

7	6	5	4	3	2	1	0
D7	D6	D5	D4	D3	D2	D1	D0

Bit	Symbol	Description
7:0	RSTR	Read: Chip ID, 0x09 Write: write 0x55 to RSTR, reset internal logic and register

GCR1, Global Control Register

Address: 0x01, R/W, default: 0x00

7	6	5	4	3	2	1	0
LE2	LE1	LE0	-	UVLOIE	OTPIE	CHGDIS	CHIPEN

Bit	Symbol	Description
7:5	LIE _x	LED _x Interrupt enable 0:Disable LED _x interrupt (default) 1:Enable LED _x interrupt
4	-	Reserved
3	UVLOIE	UVLO Interrupt enable 0:Disable UVLO interrupt (default) 1:Enable UVLO interrupt
2	OTPIE	Over Temperature Interrupt enable 0:Disable OT interrupt (default) 1:Enable OT interrupt
1	CHGDIS	Charge Indication Function Disable Select 0: enable (default) 1: disable
0	CHIPEN	Device operating Enable 0: Disable, the device is in standby state (default) 1: Enable, the device enters active state

ISR, Chip Status Register

Address: 0x02, Read only, Cleared after Read

7	6	5	4	3	2	1	0
LIS2	LIS1	LIS0	PUIS	UVLOIS	OTPIIS	-	-

Bit	Symbol	Description
7:5	LIS _x	LED _x Interrupt Status
4	PUIS	Power Up Interrupt Status 0: No power-up reset has taken place 1: Power-up reset has taken place
3	UVLOIS	UVLO Detection Status 0: no UVLO detected 1: UVLO detected
2	OTIS	Over-temperature Detection Status 0: no Over-Temperature detected 1: Over-Temperature detected
1-0	-	Reserved

PATST, Pattern Status Register

Address: 0x03, Read only, default: 0x00

7	6	5	4	3	2	1	0
-	-	-	-	-	ST2	ST1	ST0

Bit	Symbol	Description
7:3	-	Reserved

2	ST2	LED2 Pattern Status 0: Pattern is not running 1: Pattern is running
1	ST1	LED1 Pattern Status 0: Pattern is not running 1: Pattern is running
0	ST0	LED0 Pattern Status 0: Pattern is not running 1: Pattern is running

GCR2, LED Maximum Current Register

Address: 0x04, R/W, default: 0x00

7	6	5	4	3	2	1	0
DUVP	DOTP	UVDIS	OTDIS	UVTH		IMAX	

Bit	Symbol	Description
7	DUVP	Disable UVLO Protection 0: enable UVLO protection, reset CHIPEN when UVLOIS=1 (default) 1: disable UVLO protection
6	DOTP	Disable Over-temperature Protection 0: enable OTP protection, reset CHIPEN when OTPIS=1 1: disable OTP protection
5	UVDIS	Disable UVLO Detection 0: enable UVLO detection (default) 1: disable UVLO detection
4	OTDIS	Disable Over-Temperature Detection 0: enable Over-temperature detection (default) 1: disable Over-Temperature detection
3:2	UVTH	UVLO Threshold Selection 00: 2.0v (default) 01: 2.1v 10: 2.2v 11: 2.2v
1:0	IMAX	Global Max Output Current Select IMAX 00: I _{max} =15mA (default) 01: I _{max} =30mA 10: I _{max} =5mA 11: I _{max} =10mA

LCTR, LED Control Register

Address: 0x30, R/W, default: 0x00

7	6	5	4	3	2	1	0
-	-	FREQ	-	EXP	LE2	LE1	LE0

Bit	Symbol	Description
5	FREQ	PWM Carrier Frequency Selection

		0: 250Hz (default) 1: 125Hz
4	-	Reserved
3	EXP	PWM Transition mode Selection 0: Exponential transition (default) 1: Linear transition
2	LE2	LED2 Enable 0: LED2 module stop work and LED2 out disabled (default) 1: LED2 output is enabled
2	LE1	LED1 Enable 0: LED1 module stop work and LED1 out disabled (default) 1: LED1 output is enabled
0	LE0	LED0 Enable 0: LED0 module stop work and LED0 out disabled (default) 1: LED0 output is enabled

LCFG0, LED0 Mode Configuration Register

LCFG0: Address: 0x31, R/W, default: 0x00

7	6	5	4	3	2	1	0
SYNC	FO	FI	MD	CUR			

Bit	Symbol	Description
7	SYNC	Sync Mode Enable 0: Independently control mode (default) 1: Sync control mode
6	FO	Fade-out enable control, only active in manual mode 0: disable PWM fade-out (default) 1: enable PWM fade-out, the dimming time defined by T3
5	FI	Fade-in enable control, only active in manual mode 0: disable PWM fade-in (default) 1: enable PWM fade-in, the dimming time defined by T1
4	MD	LED0 Operating Mode Selection. 0: Manual mode (default) 1: Pattern mode
3:0	CUR	LED0 output Current Setting. LED0 output current $I_o = I_{max} * CUR / 15$ (mA) when PWM0 is 255.

LCFG1, LED1 Mode Configuration Register

LCFG1: Address: 0x32, R/W, default: 0x00

7	6	5	4	3	2	1	0
-	FO	FI	MD	CUR			

Bit	Symbol	Description
-----	--------	-------------

6	FO	Fade-out enable control, only active in manual mode 0: disable PWM fade-out (default) 1: enable PWM fade-out, the dimming time defined by T3
5	FI	Fade-in enable control, only active in manual mode 0: disable PWM fade-in (default) 1: enable PWM fade-in, the dimming time defined by T1
4	MD	LED1 Operating Mode Select. 0: Manual mode (default) 1: Pattern mode
3:0	CUR	LED1 output Current Setting. LED1 output current $I_o = I_{max} * CUR / 15$ (mA) when PWM1 is 255.

LCFG2, LED2 Mode Configuration Register

LCFG2: Address: 0x33, R/W, default: 0x00

7	6	5	4	3	2	1	0
-	FO	FI	MD	CUR			

Bit	Symbol	Description
6	FO	Fade-out enable control, only active in manual mode 0: disable PWM fade-out (default) 1: enable PWM fade-out, the dimming time defined by T3
5	FI	Fade-in enable control, only active in manual mode 0: disable PWM fade-in (default) 1: enable PWM fade-in, the dimming time defined by T1
4	MD	LED2 Operating Mode Selection 0: Manual mode (default) 1: Pattern mode
3:0	CUR	LED2 output Current Setting. LED2 output current $I_o = I_{max} * CUR / 15$ (mA) when PWM2 is 255.

PWM0/PWM1/PWM2 , PWM Dimming Level Register

PWM0: Address: 0x34, R/W, default:0x00

PWM1: Address: 0x35, R/W, default:0x00

PWM2: Address: 0x36, R/W, default:0x00

7	6	5	4	3	2	1	0
PWM							

Bit	Symbol	Description
7:0	PWM	PWM level for LEDx (x=0~2)

LEDxT0, T1 & T2 Configuration Register

LED0T0: Address: 0x37, R/W, default: 0x00

LED1T0: Address: 0x3A, R/W, default: 0x00

LED2T0: Address: 0x3D, R/W, default: 0x00

7	6	5	4	3	2	1	0
T1				T2			

Bit	Symbol	Description
7:4	T1	T1 (Rise-time) selection
		0000: 0.04s (default) 1000: 2.1s
		0001: 0.13s 1001: 2.6s
		0010: 0.26s 1010: 3.1s
		0011: 0.38s 1011: 4.2s
		0100: 0.51s 1100: 5.2s
		0101: 0.77s 1101: 6.2s
		0110: 1.04s 1110: 7.3s
		0111: 1.6s 1111: 8.3s
3:0	T2	T2 (On-time) selection
		0000: 0.04s (default) 1000: 2.1s
		0001: 0.13s 1001: 2.6s
		0010: 0.26s 1010: 3.1s
		0011: 0.38s 1011: 4.2s
		0100: 0.51s 1100: 5.2s
		0101: 0.77s 1101: 6.2s
		0110: 1.04s 1110: 7.3s
		0111: 1.6s 1111: 8.3s

LEDxT1, T3 & T4 Configuration Register

LED0T1: Address: 0x38, R/W, default: 0x00

LED1T1: Address: 0x3B, R/W, default: 0x00

LED2T1: Address: 0x3E, R/W, default: 0x00

7	6	5	4	3	2	1	0
T3				T4			

Bit	Symbol	Description
7:4	T3	T3 (Fall-time) selection
		0000: 0.04s (default) 1000: 2.1s
		0001: 0.13s 1001: 2.6s
		0010: 0.26s 1010: 3.1s
		0011: 0.38s 1011: 4.2s
		0100: 0.51s 1100: 5.2s

		0101:	0.77s	1101:	6.2s
		0110:	1.04s	1110:	7.3s
		0111:	1.6s	1111:	8.3s
3:0	T4	T4 (Off-time) selection			
		0000:	0.04s (default)	1000:	2.1s
		0001:	0.13s	1001:	2.6s
		0010:	0.26s	1010:	3.1s
		0011:	0.38s	1011:	4.2s
		0100:	0.51s	1100:	5.2s
		0101:	0.77s	1101:	6.2s
		0110:	1.04s	1110:	7.3s
		0111:	1.6s	1111:	8.3s

LEDxT2, T0 & Repeat Times Configuration Register

LED0T2: Address: 0x39, R/W, default: 0x00

LED1T2: Address: 0x3C, R/W, default: 0x00

LED2T2: Address: 0x3F, R/W, default: 0x00

7	6	5	4	3	2	1	0
-	T0			REPEAT			

Bit	Symbol	Description
7:4	T0	T0 (Delay time before pattern startup) selection
		0000: 0.04s (default) 1000: 2.1s
		0001: 0.13s 1001: 2.6s
		0010: 0.26s 1010: 3.1s
		0011: 0.38s 1011: 4.2s
		0100: 0.51s 1100: 5.2s
		0101: 0.77s 1101: 6.2s
		0110: 1.04s 1110: 7.3s
		0111: 1.6s 1111: 8.3s
3:0	REPEAT	Pattern Repeat Times
		0000: never stop
		0001: pattern run 1 time only
		0010: pattern run 2 times
	
		1111: pattern run 15 times

TAPE AND REEL INFORMATION

CARRIER TAPE

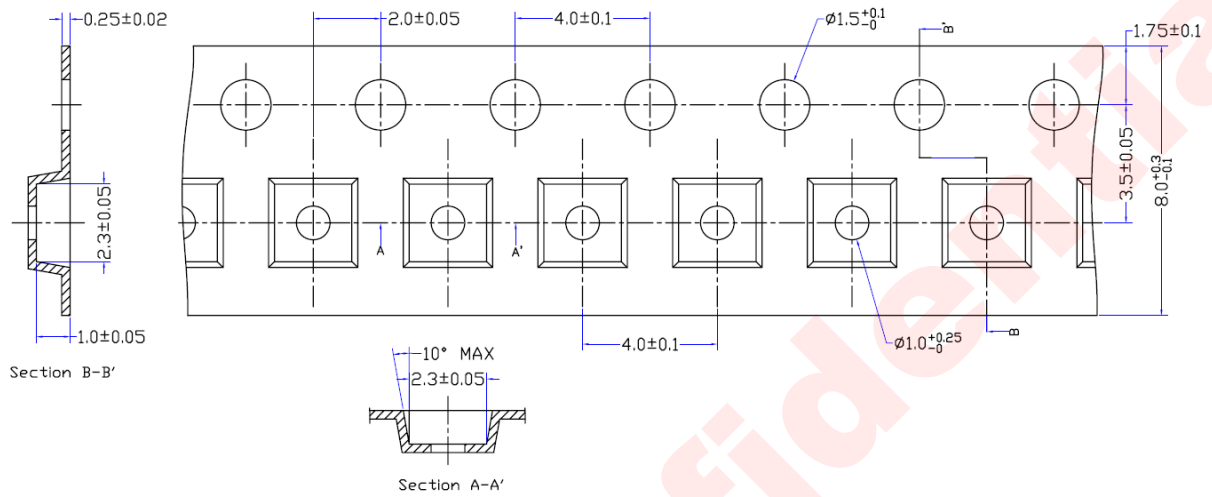

NOTE: ALL DIMS IN mm;

PIN 1

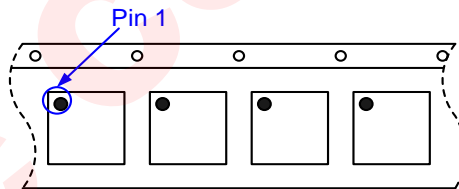

PACKAGE DESCRIPTION

DFN2x2-10L

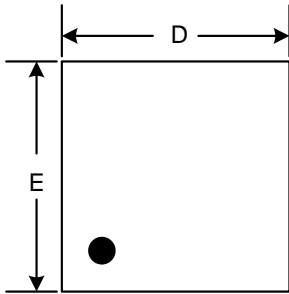

Top View

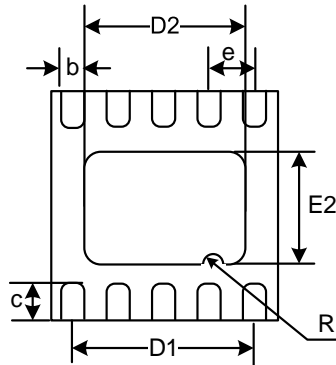

Bottom View

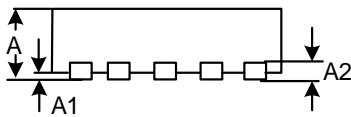

Side View

Unit:mm	DFN-10L		
Symbol	Min	Typ	Max
A	0.700	0.750	0.800
A1	0.000		0.050
A2	0.200(Ref.)		
b	0.150	0.200	0.250
c	0.250	0.300	0.350
D	1.900	2.000	2.100
D2	1.300	1.400	1.500
D1	1.600 (Ref.)		
e	0.400 (BSC)		
E	1.900	2.000	2.100
E2	0.800	0.900	1.000
R		0.10	

LAND PATTERN EXAMPLE

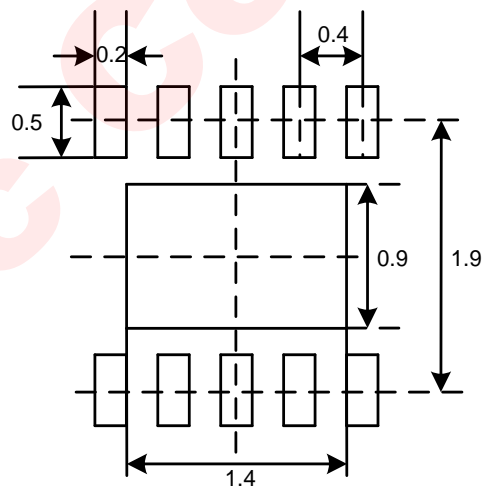

Recommended Land Pattern(Unit: mm)

REFLOW

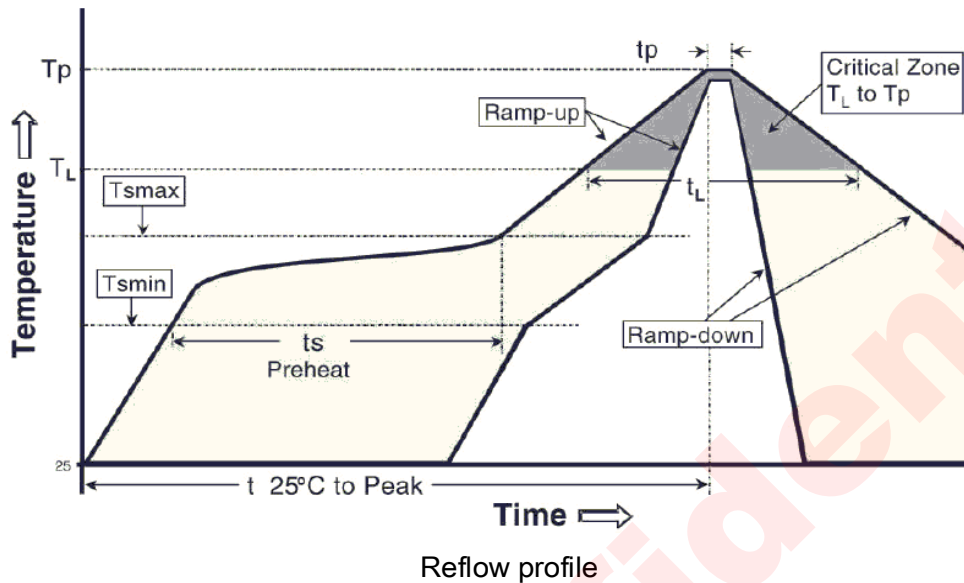

Package Reflow Oven Thermal Profile

Reflow condition	Sn-Pb eutectic assembly		Pb-Free assembly	
	Pkg. thickness ≥ 2.5 mm or Pkg. volume ≥ 350 mm ³	Pkg. thickness < 2.5 mm and Pkg. volume < 350 mm ³	Pkg. thickness ≥ 2.5 mm or Pkg. volume ≥ 350 mm ³	Pkg. thickness < 2.5 mm and Pkg. volume < 350 mm ³
Average ramp-up rate (Liquidus Temperature (T_L) to Peak)	3 °C/second max.		3 °C/second max.	
Preheat				
- Temperature Min ($T_{s(min)}$)	100 °C		150 °C	
- Temperature Max ($T_{s(max)}$)	150 °C		200 °C	
- Time (min to max) (t_s)	60-120 seconds		60-180 seconds	
$T_{s(max)}$ to T_L				
- Ramp-up Rate			3 °C/second max.	
Time maintained above:				
- Temperature (T_L)	183 °C		217 °C	
- Time (t_L)	60-150 seconds		60-150 seconds	
Peak Temperature (T_p)	225 +0/-5 °C	240 +0/-5 °C	245 +0/-5 °C	250 +0/-5 °C
Time within 5 °C of actual Peak Temperature (t_p)	10-30 seconds	10-30 seconds	10-30 seconds	20-40 seconds
Ramp-down Rate	6 °C/second max.		6 °C/second max.	
Time 25 °C to Peak Temperature	6 minutes max.		8 minutes max.	

Parameters for classification reflow profile

- Note:
1. All of the temperature parameters are measured from the top of package;
 2. AW2033 is suitable for Pb-Free assembly.

REVISION HISTORY

Vision	Date	Revision Record
V1.0	May 2017	Initial release
V1.1	Sep 2017	Update parts of functional description
V1.2	Nov 2017	Modify $F_{PWM}=250\text{Hz}$ --Page5

DISCLAIMER

Information in this document is believed to be accurate and reliable. However, Shanghai AWINIC Technology Co., Ltd (AWINIC Technology) does not give any representations or warranties, expressed or implied, as to the accuracy or completeness of such information and shall have no liability for the consequences of use of such information.

AWINIC Technology reserves the right to make changes to information published in this document, including without limitation specifications and product descriptions, at any time and without notice. Customers shall obtain the latest relevant information before placing orders and shall verify that such information is current and complete. This document supersedes and replaces all information supplied prior to the publication hereof.

AWINIC Technology products are not designed, authorized or warranted to be suitable for use in medical, military, aircraft, space or life support equipment, nor in applications where failure or malfunction of an AWINIC Technology product can reasonably be expected to result in personal injury, death or severe property or environmental damage. AWINIC Technology accepts no liability for inclusion and/or use of AWINIC Technology products in such equipment or applications and therefore such inclusion and/or use is at the customer's own risk.

Applications that are described herein for any of these products are for illustrative purposes only. AWINIC Technology makes no representation or warranty that such applications will be suitable for the specified use without further testing or modification.

All products are sold subject to the general terms and conditions of commercial sale supplied at the time of order acknowledgement.

Nothing in this document may be interpreted or construed as an offer to sell products that is open for acceptance or the grant, conveyance or implication of any license under any copyrights, patents or other industrial or intellectual property rights.

Reproduction of AWINIC information in AWINIC data books or data sheets is permissible only if reproduction is without alteration and is accompanied by all associated warranties, conditions, limitations, and notices. AWINIC is not responsible or liable for such altered documentation. Information of third parties may be subject to additional restrictions.

Resale of AWINIC components or services with statements different from or beyond the parameters stated by AWINIC for that component or service voids all express and any implied warranties for the associated AWINIC component or service and is an unfair and deceptive business practice. AWINIC is not responsible or liable for any such statements.