

0.1-3.8 GHz SP10T TRX Switch with MIPI

Features

- Broadband frequency range: 0.1 to 3.8 GHz
- Low insertion loss: 0.65dB typical @ 2.7 GHz
- High isolation: 24dB typical @ 2.7 GHz
- P0.1dB @ 37dBm
- MIPI RFFE V2.1 interface
- QFN 2.4mm x 2.4mm x 0.55mm - 20L package
- No DC blocking capacitors required (unless external DC is applied to the RF ports)

Applications

- 2G/3G/4G antenna diversity
- Cellular modems , tablets and USB Devices
- Other RF front-end modules

General Description

The AW13510TQNR is a SP10T switch with low insertion loss and high isolation. It can be used to support band switching and mode switching in antenna transmit and receive systems for 2G/3G/4G, data cards and tablets.

The AW13510TQNR is perfectly compatible with MIPI RFFE V2.1 control interface. It is provided in a compact QFN 2.4mm x 2.4mm x 0.55mm-20L package.

Typical Application Circuit

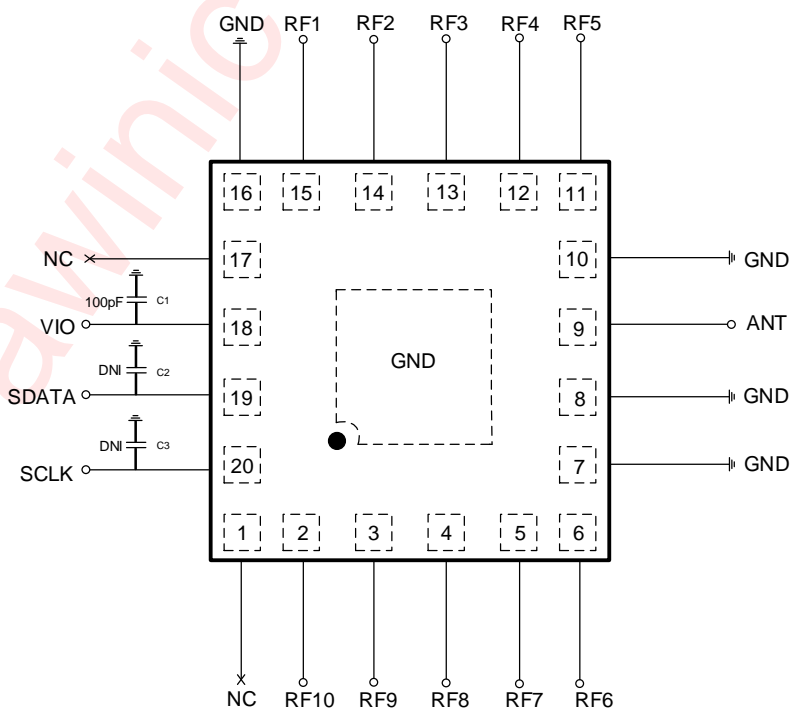

Figure 1 Typical Application Circuit of AW13510TQNR

Pin Configuration And Top Mark

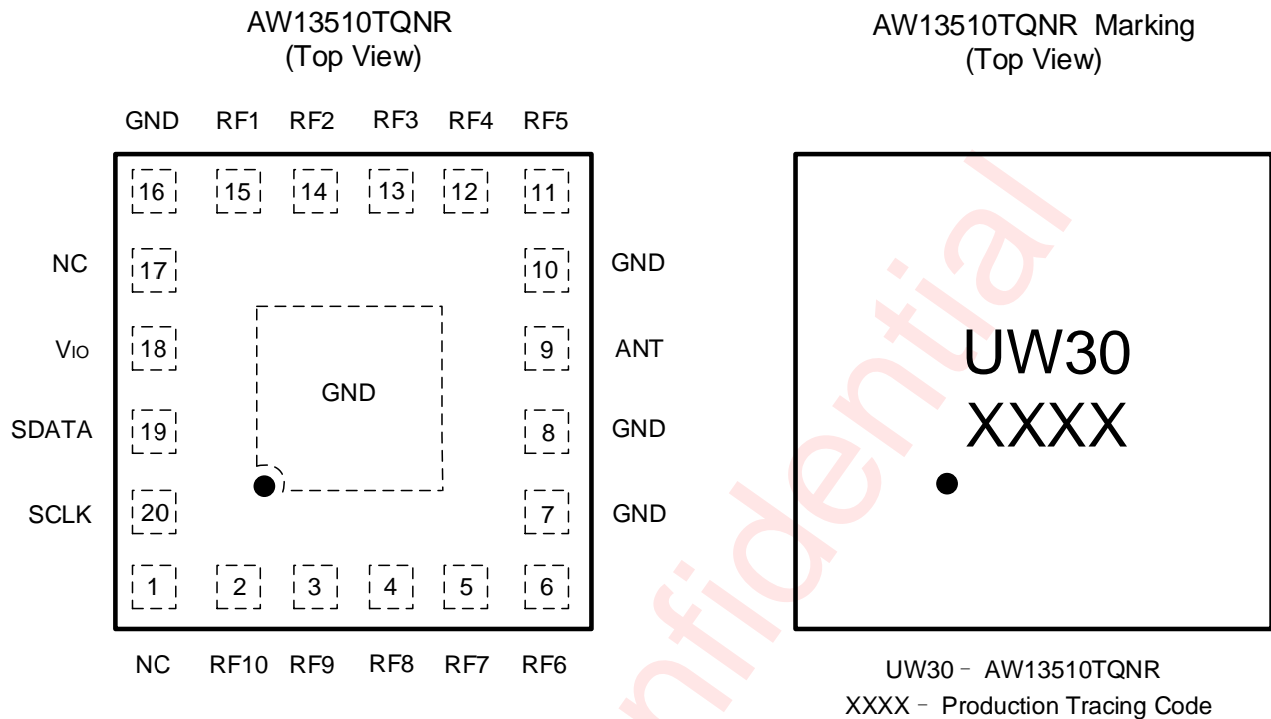

Figure 2 Pin Configuration and Top Mark

Pin Definition

No.	NAME	DESCRIPTION
1	NC	Not connect
2	RF10	RF10 port
3	RF9	RF9 port
4	RF8	RF8 port
5	RF7	RF7 port
6	RF6	RF6 port
7	GND	Ground
8	GND	Ground
9	ANT	Antenna port
10	GND	Ground
11	RF5	RF5 port
12	RF4	RF4 port

13	RF3	RF3 port
14	RF2	RF2 port
15	RF1	RF1 port
16	GND	Ground
17	NC	Not connect
18	V _{IO}	Power supply
19	SDATA	MIPI data input/output
20	SCLK	MIPI clock

Functional Block Diagram

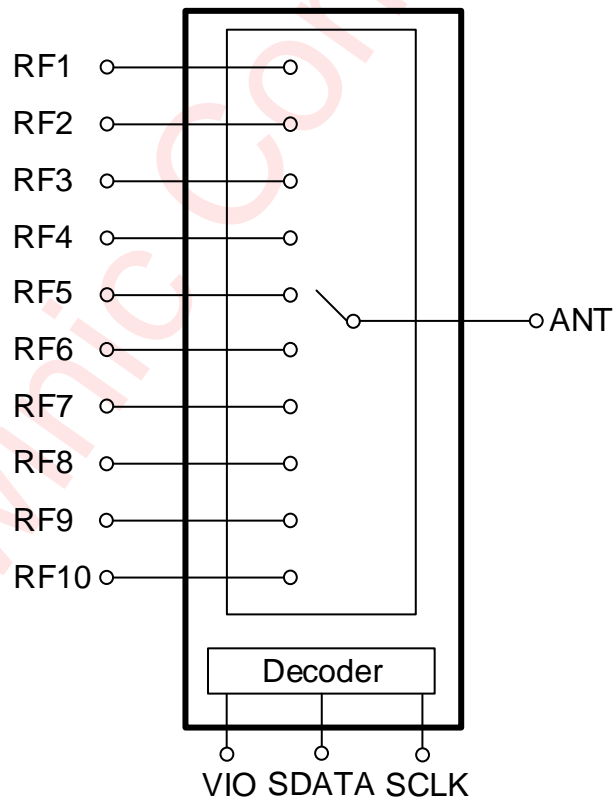

Figure 3 Functional Block Diagram

Ordering Information

Part Number	Temperature	Package	Marking	Moisture Sensitivity Level	Environmental Information	Delivery Form
AW13510TQNR	-40°C~85°C	QFN 2.4mm x 2.4mm x 0.55mm -20L	UW30	MSL1	ROHS+HF	6000 units/Tape and Reel

Absolute Maximum Ratings (NOTE 1)

PARAMETERS	RANGE
Interface Supply Voltage Range V_{IO}	-0.3V to 2.5V
Interface Control Voltage Range SDATA, SCLK	-0.3V to 2.5V
RF input power (RF1 to RF10)	38dBm
Operating Free-air Temperature Range	-40°C to 85°C
Storage temperature T_{STG}	-65°C to 150°C
Lead temperature (soldering 10 seconds)	260°C
ESD	
HBM(Human Body Model) <small>(NOTE 2)</small>	±1000V
CDM (Charged Device Model) <small>(NOTE 3)</small>	±500V

NOTE1: Conditions out of those ranges listed in "absolute maximum ratings" may cause permanent damages to the device. In spite of the limits above, functional operation conditions of the device should within the ranges listed in "recommended operating conditions". Exposure to absolute-maximum-rated conditions for prolonged periods may affect device reliability.

NOTE2: The human body model is a 100pF capacitor discharged through a 1.5kΩ resistor into each pin. Test method: ESDA/JEDEC JS-001-2017.

NOTE3: All pins. Test Condition: ESDA/JEDEC JS-002-2018.

Electrical Characteristics

$V_{IO}=1.8V$, $P_{IN}=0dBm$, $VSWR=1:1$, $Temp=25^{\circ}C$. (unless otherwise noted)

PARAMETER	TEST CONDITION	MIN	TYP	MAX	UNIT	
DC Specifications						
V_{IO}	Supply Voltage	1.6	1.8	2.0	V	
I_{VIO}	V_{IO} Supply Current	Active Mode	37	65	μA	
		Low Power Mode	2	10	μA	
V_{IH}	SDATA,SCLK Control Voltage High	Must not exceed V_{IO} voltage	$0.8^* V_{IO}$	V_{IO}	V	
V_{IL}	SDATA,SCLK Control Voltage Low	Must not exceed V_{IO} voltage	0	0	0.3^*V_{IO} V	
T_{ON}	Wakeup Time	From end of Low Power State 50% SCLK to 90% of final RF power	10	20	μs	
T_{sw}	Switching Speed One RF port to another	10% to 90% RF	0.75	1.6	μs	
RF Specifications						
IL	Insertion loss (ANT pin to RF pins)	0.1-1.0GHz		0.55	0.70	dB
		1.0-2.0GHz		0.60	0.80	dB
		2.0-2.7GHz		0.65	0.90	dB
		3.3-3.8GHz		0.75	1.0	dB
RL	Return loss (ANT pin to RF pins)	0.1-1.0GHz	18	24		dB
		1.0-2.0GHz	15	20		dB
		2.0-2.7GHz	12	18		dB
		3.3-3.8GHz	10	15		dB
ISO	Isolation (ANT pin to RF pins)	0.1-1.0GHz	25	30		dB
		1.0-2.0GHz	22	27		dB
		2.0-2.7GHz	20	24		dB
		3.3-3.8GHz	18	22		dB

PARAMETER		TEST CONDITION	MIN	TYP	MAX	UNIT
2f ₀	Second Harmonics (ANT pin to RF pins)	Freq@900MHz, P _{IN} =+26dBm,CW		90		dBc
3f ₀	Third Harmonics (ANT pin to RF pins)	Freq@900MHz, P _{IN} =+26dBm,CW		84		dBc
2f ₀	Second Harmonics (ANT pin to RF pins)	Freq@1900MHz, P _{IN} =+26dBm,CW		92		dBc
3f ₀	Third Harmonics (ANT pin to RF pins)	Freq@1900MHz, P _{IN} =+26dBm,CW		90		dBc
P _{0.1dB}	0.1dB Compression Point (ANT pin to RF pins)	0.1-3.8GHz		37		dBm

Timing Diagram (Power On and Off Sequence)

- Once V_{IO} is powered down to 0 V, wait at least $10\ \mu\text{s}$ to reapply power to V_{IO} .

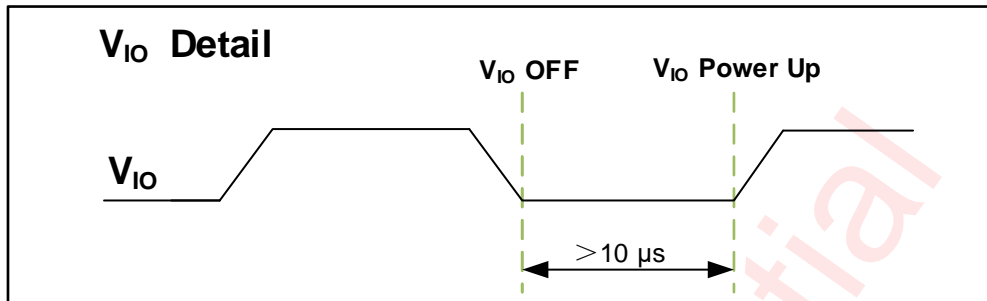

Figure 4 Digital Supply Detail

- Before applying RF power, V_{IO} must be turned on for at least $20\ \mu\text{s}$.

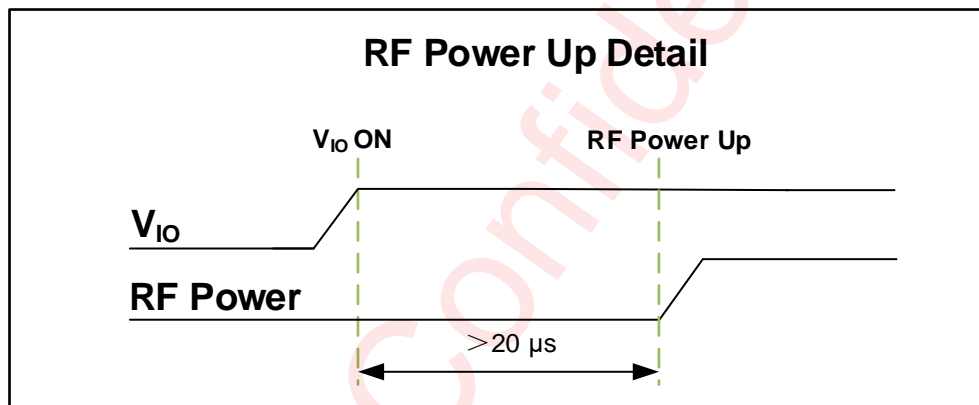

Figure 5 RF Power-Up Detail

- Before sending SDATA/SCLK, V_{IO} must be applied for at least $800\ \text{ns}$ to ensure correct data transmission. And after the RFFE bus is idle, wait at least $20\ \mu\text{s}$ to apply the RF signal.

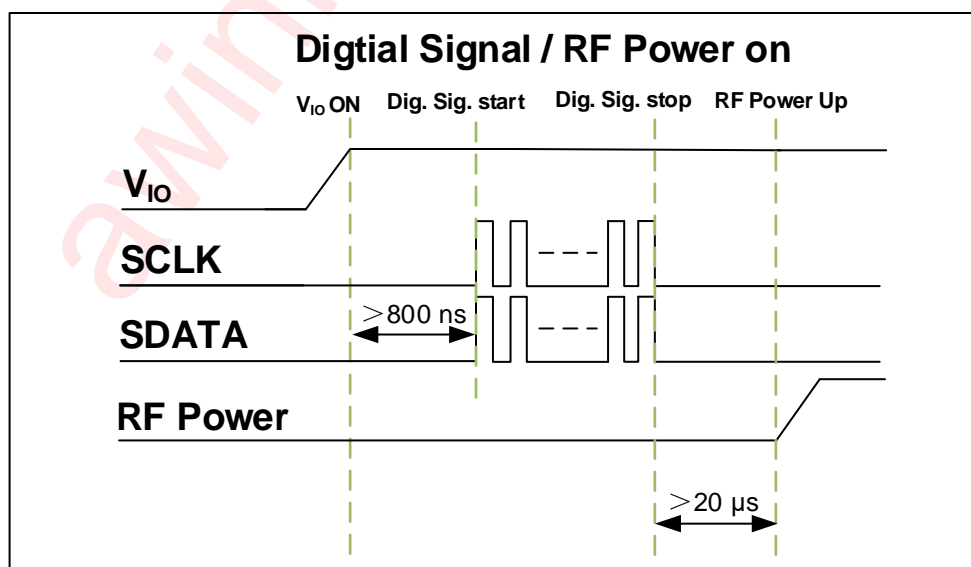

Figure 6 Digital Signal / RF Power-On Detail

- There shall be no RFFE bus operations during RF Signal active to protect the device. So RF input signal shall be applied after RFFE bus operations being finished and be removed before RFFE bus operations being started.

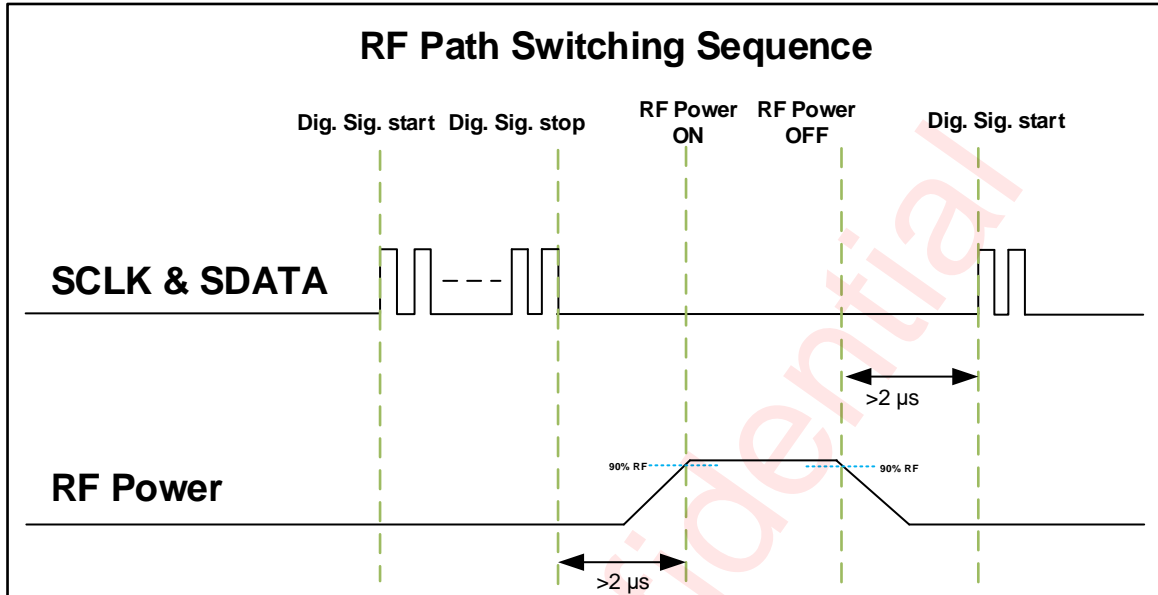

Figure 7 RF Path Switching Sequence

- If "Lower Power Mode" is used, there must be a $10 \mu\text{s}$ delay before exiting "Lower Power Mode".

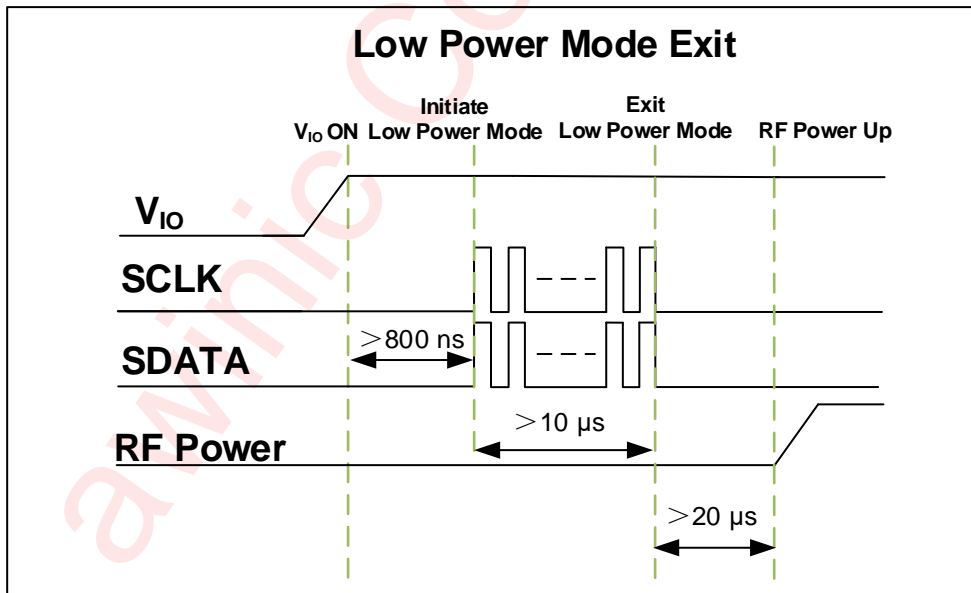

Figure 8 Lower Power Mode Exit Timing

MIPI RFFE Specification

The MIPI RFFE interface is working in systems following the 'MIPI Alliance Specification for RF Front-End Control Interface version 2.1.

TABLE1: MIPI FEATURES

Feature	Supported	Comment
MIPI RFFE 2.1 standard	Yes	
Register 0 write command sequence	Yes	
Register read and write command sequence	Yes	
Extended register read and write command sequence	Yes	
Masked write command sequence	Yes	Indicated as MW in below register mapping tables
Support for standard frequency range operations for SCLK	Yes	Up to 26 MHz for read and write
Support for extended frequency range operations for SCLK	Yes	Up to 52 MHz for write
Half speed read	Yes	
Full speed read Full speed write	Yes	
Longer Reach RFFE Bus Length Feature	Yes	
Programmable driver strength	Yes	
Programmable Group SID	Yes	
Programmable USID	Yes	Support for three registers write and extended write sequences
Trigger functionality	Yes	
Extended Triggers and Trigger Masks	Yes	
Broadcast / GSID write to PM TRIG register	Yes	
Reset	Yes	Via VIO, PM TRIG or software register
Status / error sum register	Yes	
Extended product ID register	Yes	
Revision ID register	Yes	
Group SID register	Yes	
USID select pin	No	

TABLE2: Start-up Behavior

Feature	State	Comment
Power status	Low power mode	Low power mode after start-up
Trigger function	Enable	Enable after start-up. Programmable via register

MIPI Read and Write Timing

Register 0 Write:

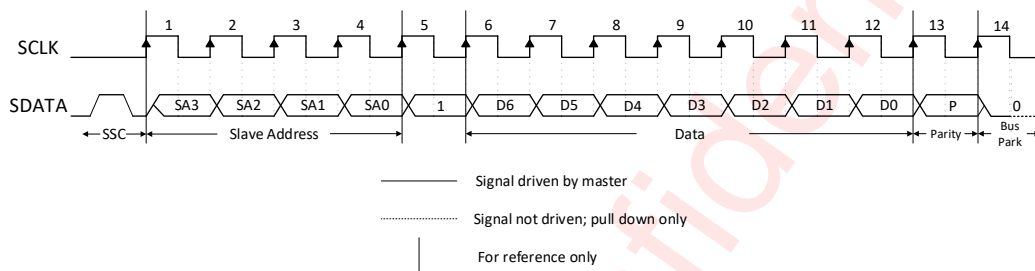

Figure 9 Register 0 Write Command Sequence

Register Write:

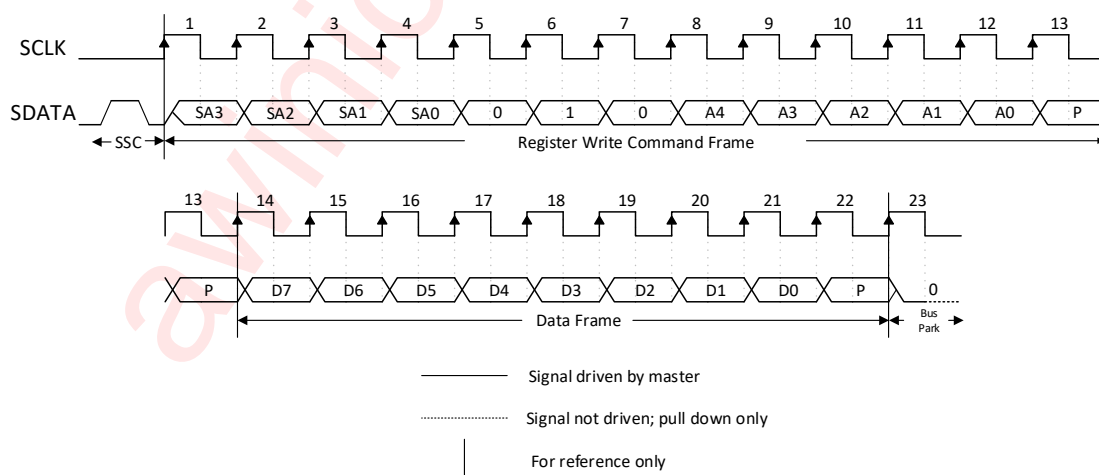

Figure 10 Register Write Command Sequence

Register Read:

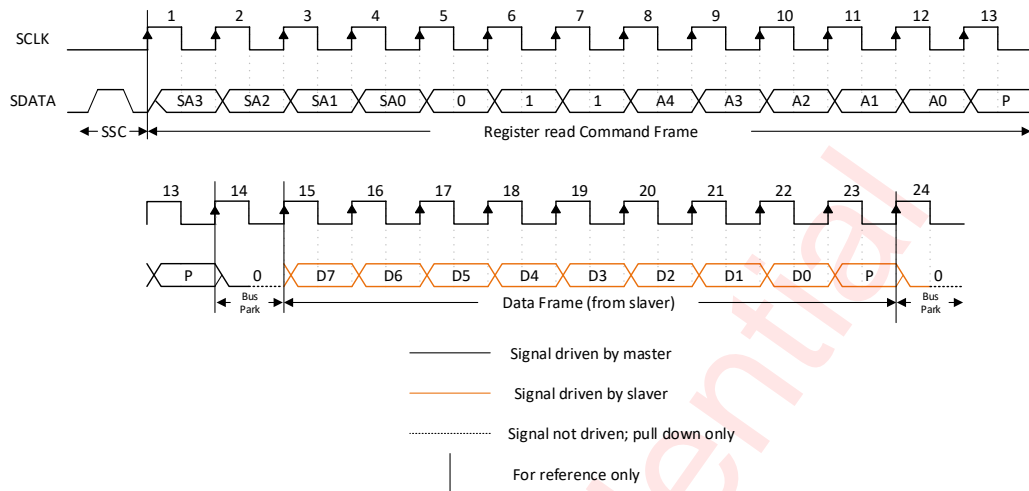

Figure 11 Register Read Command Sequence

Extended Register Write:

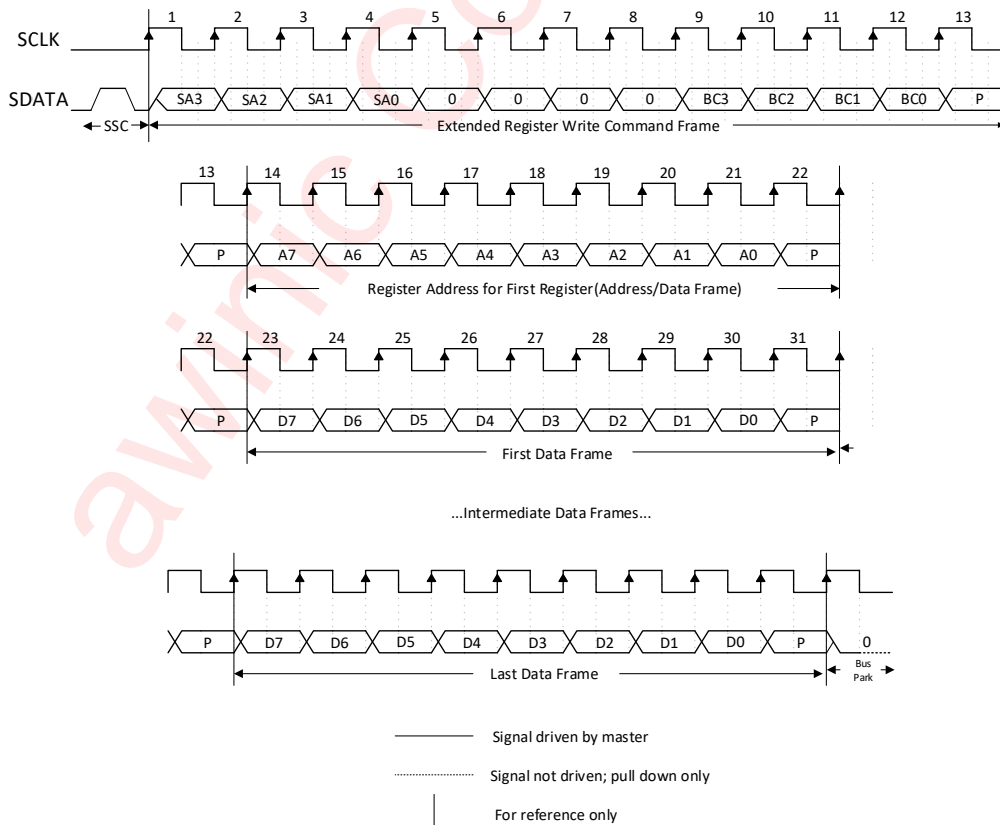

Figure 12 Extended Register Write Command Sequence

Extended Register Read:

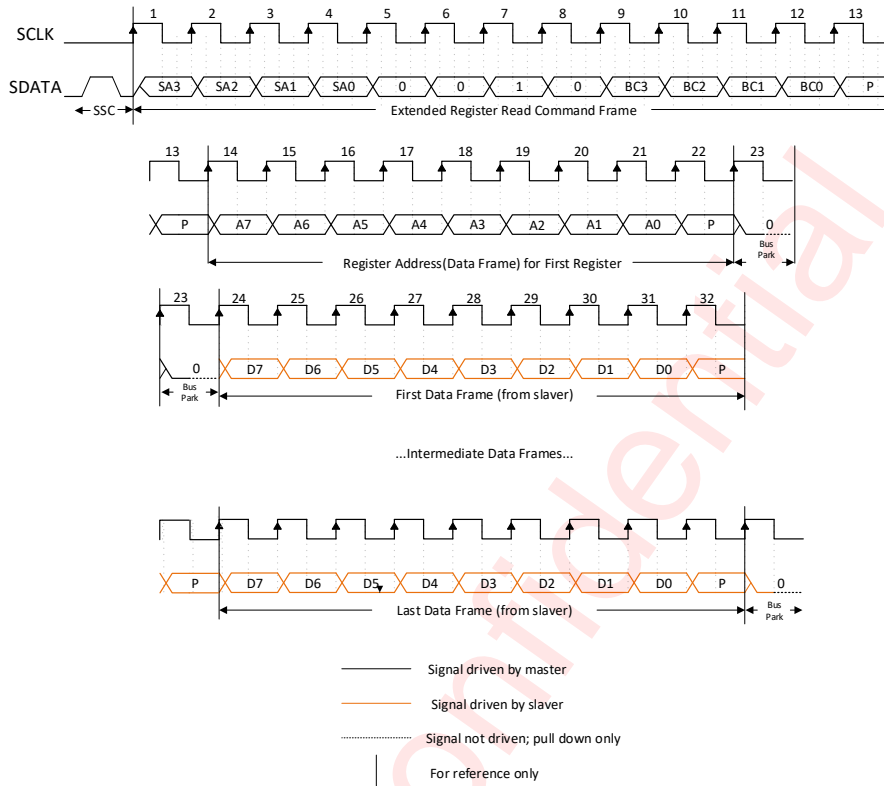

Figure 13 Extended Register Read Command Sequence

Masked Write:

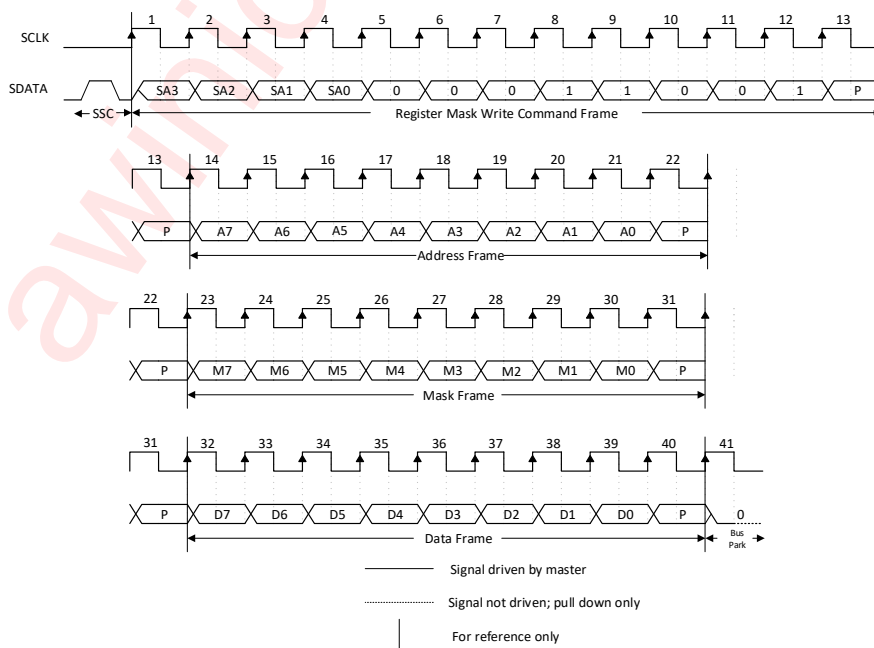

Figure 14 Masked Write Command Sequence

Register Configuration

Register Detailed Description

REGISTER_0 : Mode Control Register(Address 0000h)

		Register_0 Bits							
State	Mode	D7	D6	D5	D4	D3	D2	D1	D0
1	ALL OFF	0	0	0	0	0	0	0	0
2	RF2 ON	x	x	x	x	x	x	1	x
3	RF3 ON	x	x	x	x	x	1	x	x
4	RF4 ON	x	x	x	x	1	x	x	x
5	RF6 ON	x	x	x	1	x	x	x	x
6	RF7 ON	x	x	1	x	x	x	x	x
7	RF8 ON	x	1	x	x	x	x	x	x
8	RF9 ON	1	x	x	x	x	x	x	x

REGISTER_1 : Mode Control Register(Address 0001h)

		Register_1 Bits							
State	Mode	D7	D6	D5	D4	D3	D2	D1	D0
1	ALL OFF	0	0	0	0	0	0	0	0
2	RF1 ON	x	x	x	x	1	x	x	x
3	RF5 ON	x	x	x	x	x	x	1	x
4	RF10 ON	x	x	x	x	x	1	x	x

RFFE_STATUS : RFFE Status Register(Address 001Ah)

Bit	Symbol	Description	R/W	B/G	Trig	Default
7	UDR_RST	Reset all configurable non-RFFE reserved register to default values 0: normal operation 1: software reset	W	No	No	0
6	CMD_FR_P_ERR	Command Frame received with a parity error	RW	No	No	0
5	CMD_LEN_ERR	Command Sequence received with an incorrect length	RW	No	No	0
4	ADDR_FR_P_ERR	Address Frame received with a parity error	RW	No	No	0
3	DATA_FR_P_ERR	Data Frame received with a parity error	RW	No	No	0
2	RD_INVLD_ADDR	Read Command Sequence received with an invalid address	RW	No	No	0
1	WR_INVLD_ADDR	Write Command Sequence received with an invalid address	RW	No	No	0
0	BID_GID_ERR	Read Command Sequence received with a BSID or GSID	RW	No	No	0

GSID0_1 : Group ID 0-1 Register(Address 001Bh)

Bit	Symbol	Description	R/W	B/G	Trig	Default
7:4	GSID0	Group Slave ID0	RW	No	No	0000
3:0	GSID1	Group Slave ID1	RW	No	No	0000

PM_TRIG : Pwr_mode and Trig Register(Address 001Ch)

Bit	Symbol	Description	R/W	B/G	Trig	Default
7	PWR_MODE[1]	0: normal operation 1: low power	RW MW	Yes	No	1
6	PWR_MODE[0]	0: active 1: start up – Reset all register to default	RW MW	Yes	No	0
5:3	TRIGGER_MASK	Setting bit TRIGGER[n] loads TRIGGER[n]'s associated register	RW MW	No	No	000
2:0	TRIGGER	Setting bit TRIGGER[n] loads TRIGGER[n]'s associated register	RW MW	Yes	No	000

PRODUCT_ID : Product ID Register(Address 001Dh)

Bit	Symbol	Description	R/W	B/G	Trig	Default
7:0	PROD_ID	Lower eight bits of Product ID	R	No	No	0x0F

MANUFACTURER_ID : Manufacture ID Register(Address 001Eh)

Bit	Symbol	Description	R/W	B/G	Trig	Default
7:0	MFG_ID	Lower eight bits of Manufacturer ID	R	No	No	0x49

MAN_USID : User ID Register(Address 001Fh)

Bit	Symbol	Description	R/W	B/G	Trig	Default
7:4	MFG_ID	Upper four bits of Manufacturer ID	R	No	No	0000
3:0	USID	Unique Slave ID	RW	No	No	1010

EXT_PRODUCT_ID : Extend Product ID Register(Address 0020h)

Bit	Symbol	Description	R/W	B/G	Trig	Default
7:0	PROD_ID	Upper eight bits of Product ID	R	No	No	0x00

REVISION_ID : Revision ID Register(Address 0021h)

Bit	Symbol	Description	R/W	B/G	Trig	Default
7:0	REV_ID	Revision ID	R	No	No	0x00

GSID2_3 : Group ID 2-3 Register(Address 0022h)

Bit	Symbol	Description	R/W	B/G	Trig	Default
7:4	GSID2	Group Slave ID2	R/W	No	No	0000
3:0	GSID3	Group Slave ID3	R/W	No	No	0000

UDR_RST : UDR Reset Register(Address 0023h)

Bit	Symbol	Description	R/W	B/G	Trig	Default
7	UDR_RST	Reset all configurable non-RFFE reserved register to default values 0: normal 1: software reset	R/W	Yes	No	0
6:0	RESERVED	Reserved	R/W	No	No	0x00

ERR_SUM : Error Command Status Register(Address 0024h)

Bit	Symbol	Description	R/W	B/G	Trig	Default
7	SPARE	Reserved for future use	R/W	No	No	0
6	COM_FR_P_ERR	Command Frame received with a parity error	R/W	No	No	0
5	COM_LEN_ERR	Command Sequence received with an incorrect length	R/W	No	No	0
4	ADDR_FR_P_ERR	Address Frame received with a parity error	R/W	No	No	0
3	DATA_FR_P_ERR	Data Frame received with a parity error	R/W	No	No	0
2	RD_INVLD_ADDR	Read Command Sequence received with an invalid address	R/W	No	No	0
1	WR_INVLD_ADDR	Write Command Sequence received with an invalid address	R/W	No	No	0
0	BID_GID_ERR	Read Command Sequence received with a BSID or GSID	R/W	No	No	0

BUS_LD : SDATA Driver Strength Register(Address 002Bh)

Bit	Symbol	Description	R/W	B/G	Trig	Default
7:1	reserved	reserved	R/W	No	No	0x00
0	BUS_LD	SDATA drive strength 0: 50pf 1: 80pf	R/W	No	No	0

EXT_TRIG_MASK : Extend Trig Mask Register(Address 002Dh)

Bit	Symbol	Description	R/W	B/G	Trig	Default
7:0	EXT_TRIG_MASK	Setting bit EXT_TRIG_MASK[n] disables EXT_TRIG[n]	RW MW	No	No	0xFF

EXT_TRIG : Extend Trig Register(Address 002Eh)

Bit	Symbol	Description	R/W	B/G	Trig	Default
7:0	EXT_TRIG	Setting bit EXT_TRIG[n] loads EXT_TRIG[n]'s associated register	R/W MW	Yes	No	0x00

Tape And Reel Information

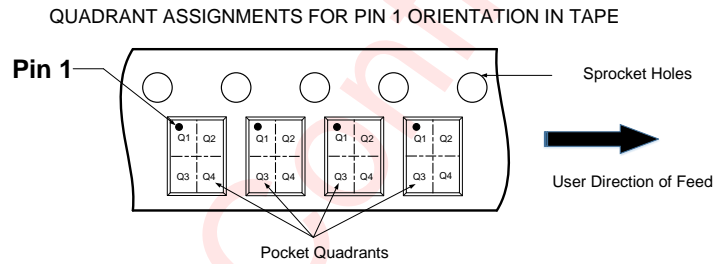
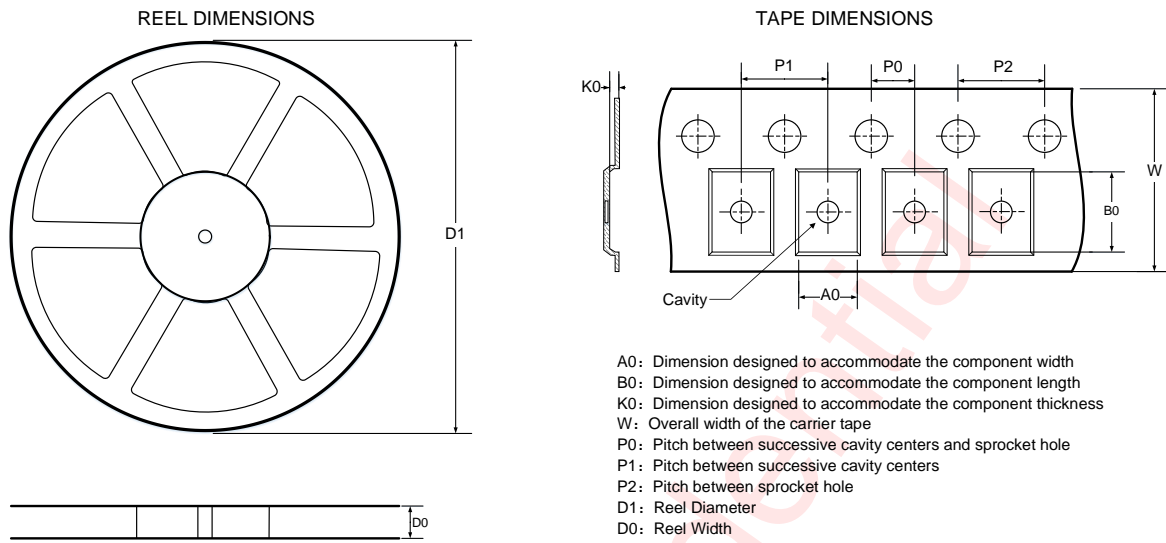

Note: The above picture is for reference only. Please refer to the value in the table below for the actual size

DIMENSIONS AND PIN1 ORIENTATION

D1 (mm)	D0 (mm)	A0 (mm)	B0 (mm)	K0 (mm)	P0 (mm)	P1 (mm)	P2 (mm)	W (mm)	Pin1 Quadrant
330	12.4	2.65	2.65	0.75	2	4	4	12	Q1

All dimensions are nominal

Figure 15 Tape and Reel

Package Description

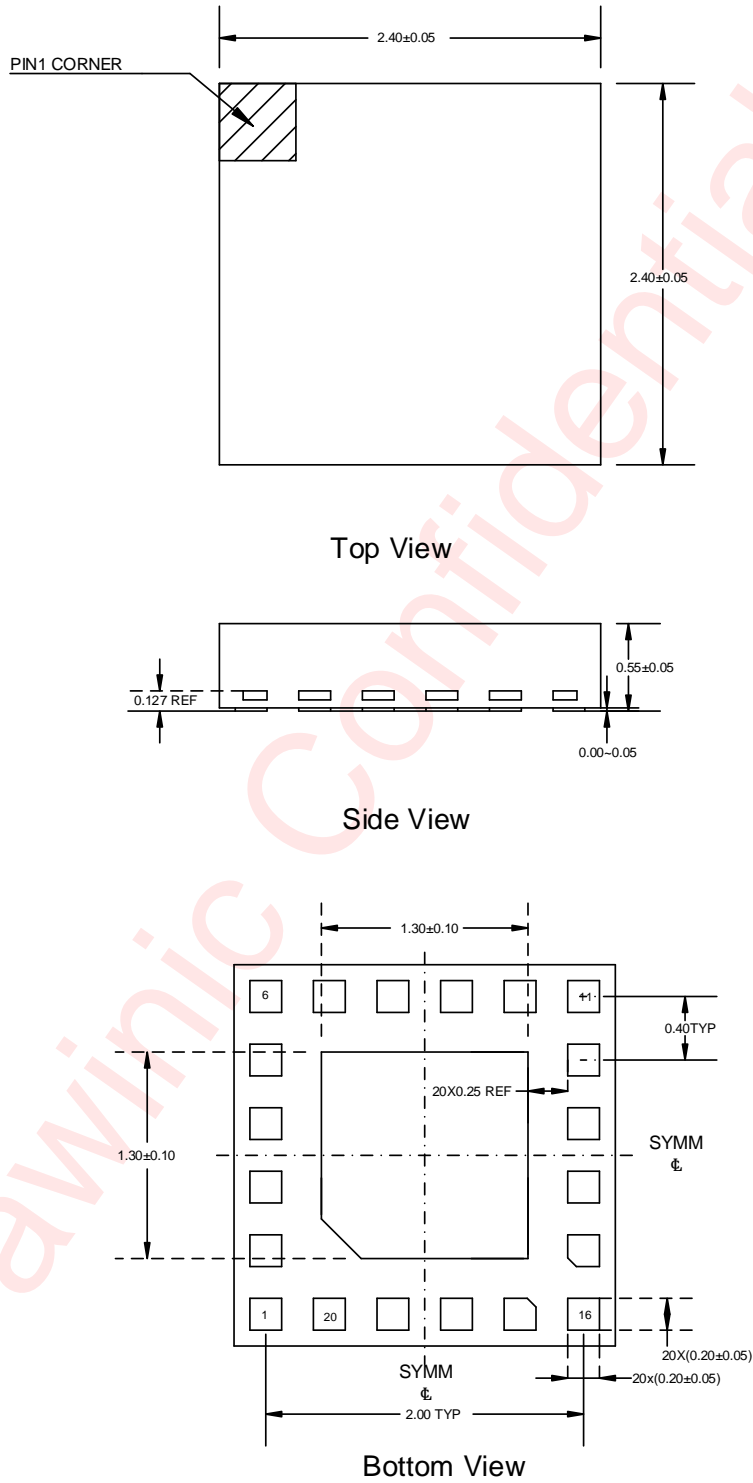

Unit: mm

Figure 16 Package Outline

Land Pattern Data

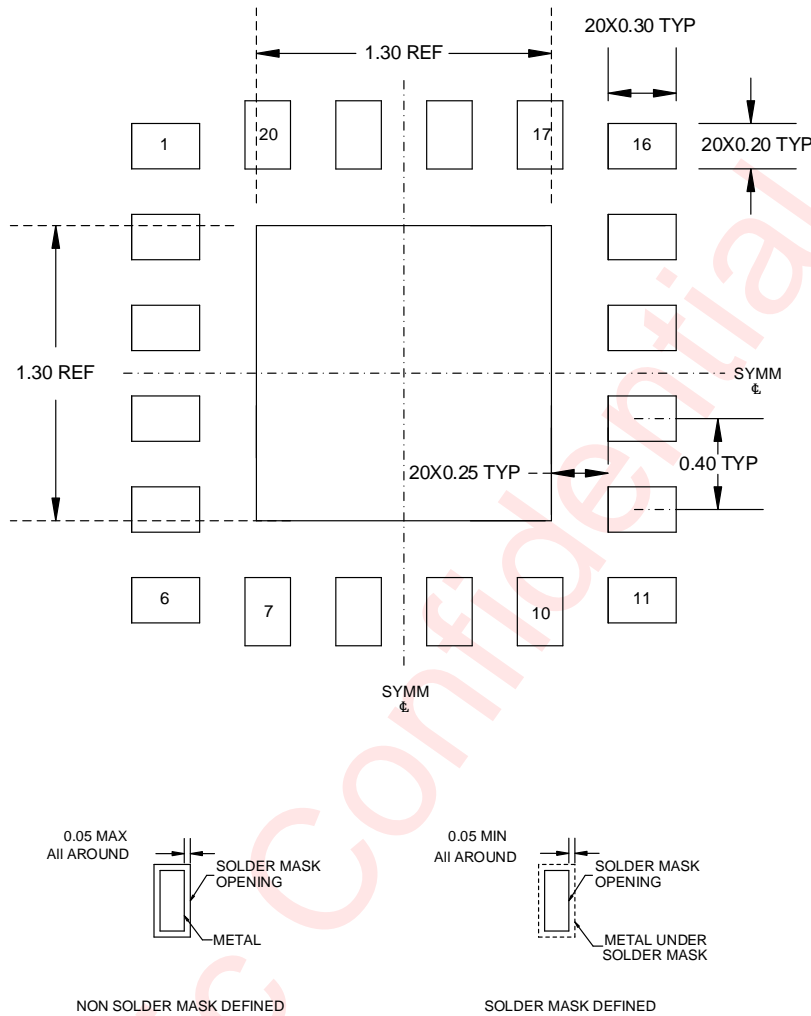

Unit: mm

Figure 17 Land Pattern Data

Revision History

Version	Date	Change Record
V1.0	Jan. 2022	Officially released
V1.1	Feb. 2022	Update Supply Voltage Range and Control Voltage Range (P4&P5) Change the spec of T _{sw} (P5)
V1.2	Aug. 2022	Fix Some Formatting issues

awinic Confidential

Disclaimer

All trademarks are the property of their respective owners. Information in this document is believed to be accurate and reliable. However, Shanghai AWINIC Technology Co., Ltd (AWINIC Technology) does not give any representations or warranties, expressed or implied, as to the accuracy or completeness of such information and shall have no liability for the consequences of use of such information.

AWINIC Technology reserves the right to make changes to information published in this document, including without limitation specifications and product descriptions, at any time and without notice. Customers shall obtain the latest relevant information before placing orders and shall verify that such information is current and complete. This document supersedes and replaces all information supplied prior to the publication hereof.

AWINIC Technology products are not designed, authorized or warranted to be suitable for use in medical, military, aircraft, space or life support equipment, nor in applications where failure or malfunction of an AWINIC Technology product can reasonably be expected to result in personal injury, death or severe property or environmental damage. AWINIC Technology accepts no liability for inclusion and/or use of AWINIC Technology products in such equipment or applications and therefore such inclusion and/or use is at the customer's own risk.

Applications that are described herein for any of these products are for illustrative purposes only. AWINIC Technology makes no representation or warranty that such applications will be suitable for the specified use without further testing or modification.

All products are sold subject to the general terms and conditions of commercial sale supplied at the time of order acknowledgement.

Nothing in this document may be interpreted or construed as an offer to sell products that is open for acceptance or the grant, conveyance or implication of any license under any copyrights, patents or other industrial or intellectual property rights.

Reproduction of AWINIC information in AWINIC data books or data sheets is permissible only if reproduction is without alteration and is accompanied by all associated warranties, conditions, limitations, and notices. AWINIC is not responsible or liable for such altered documentation. Information of third parties may be subject to additional restrictions.

Resale of AWINIC components or services with statements different from or beyond the parameters stated by AWINIC for that component or service voids all express and any implied warranties for the associated AWINIC component or service and is an unfair and deceptive business practice. AWINIC is not responsible or liable for any such statements.