

0.1-6GHz SPDT Switch for High Power Applications

Features

- Broadband frequency range: 0.1 to 6 GHz
- High power handing capability of up to 38 dBm
- Low insertion loss : 0.62 dB typical @ 6.0 GHz
- High isolation: 25 dB typical @ 6.0 GHz
- High switching speed: 1 us typical
- Low harmonic generation
- Small FCLGA (6-pin, 1.1mm x 0.7mm x 0.47mm) package

Applications

- Multi-Mode GSM/CDMA/WCDMA/LTE and NR including n77, n78, n79 bands
- Cellular modems, tablets and USB Devices
- Other RF front-end modules

General Description

The AW13612FLR is a single-pole dual-throw switch with high power handing capability of up to 38dBm and low insertion loss. It can be used to support band switching and mode switching for GSM, WCDMA, LTE, and NR applications.

The symmetrical design of internal ports makes it convenient for PCB routing and adjustment of receiving and transmitting signals. The band/mode switching is realized by the GPIO pins as referenced in the chip block diagram and the control logic.

The AW13612FLR is provided in a compact FCLGA 1.1mm x 0.7mm x 0.47mm-6L package.

Typical Application Circuit

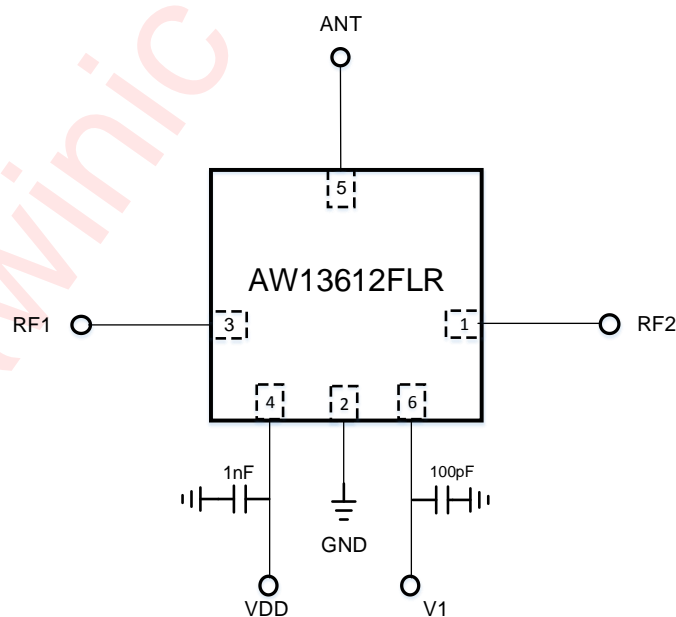

Figure 1 Typical Application Circuit of AW13612FLR

Pin Configuration And Top Mark

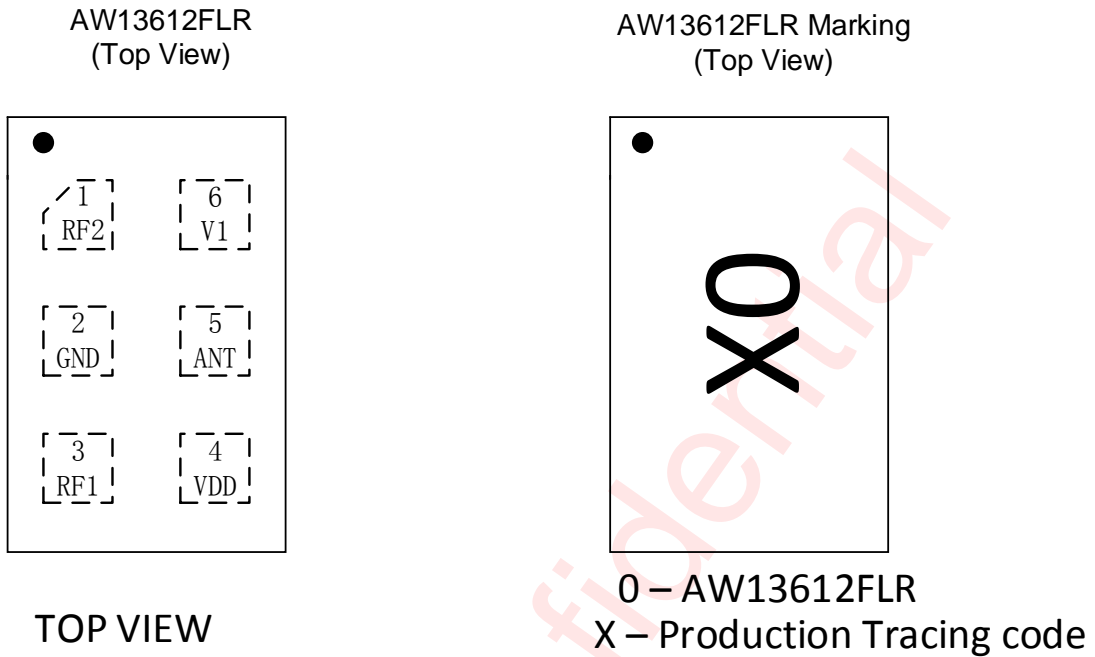

Figure 2 Pin Configuration and Top Mark

Pin Definition

No.	NAME	DESCRIPTION
1	RF2	RF I/O path 2
2	GND	Ground
3	RF1	RF I/O path 1
4	VDD	DC power supply
5	ANT	Antenna port
6	V1	DC control voltage 1

Functional Block Diagram

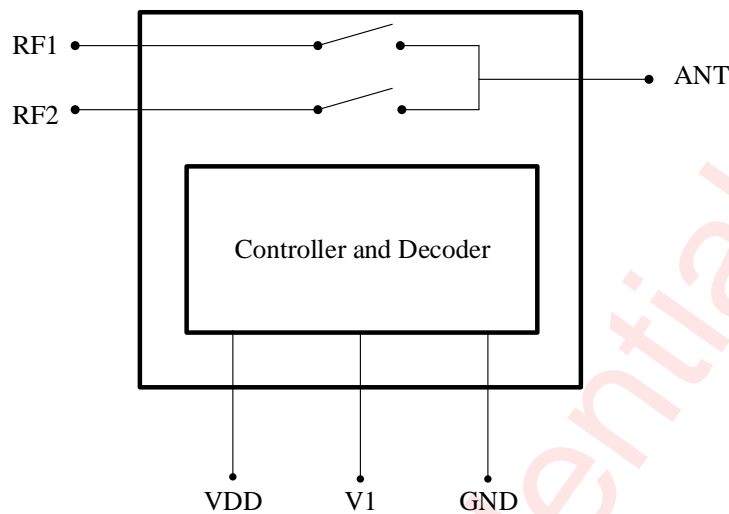

Figure 3 FUNCTIONAL BLOCK DIAGRAM

Ordering Information

Part Number	Temperature	Package	Marking	Moisture Sensitivity Level	Environmental Information	Delivery Form
AW13612 FLR	-40°C~85°C	FCLGA 1.1mmX0.7mm- 6L	0	MSL3	ROHS+HF	3000 units/ Tape and Reel

Absolute Maximum Ratings^(NOTE1)

PARAMETERS	RANGE
Supply voltage range V_{BUS}	-0.3V to 3.6V
Control Voltage Range	V1
RF input power(RF1/RF2)	39dBm
Operating Free-air Temperature Range	-40°C to 85°C
Storage temperature T_{STG}	-65°C to 150°C
Lead temperature (soldering 10 seconds)	260°C
ESD	
HBM(Human Body Model) ^(NOTE 2)	±1000V
CDM (Charged Device Model) ^(NOTE 3)	±500V

NOTE1: Conditions out of those ranges listed in "absolute maximum ratings" may cause permanent damages to the device. In spite of the limits above, functional operation conditions of the device should be within the ranges listed in "recommended operating conditions". Exposure to absolute-maximum-rated conditions for prolonged periods may affect device reliability.

NOTE2: The human body model is a 100pF capacitor discharged through a 1.5kΩ resistor into each pin. Test method: ESDA/JEDEC JS-001-2017.

NOTE3: All pins. Test Condition: ESDA/JEDEC JS-002-2018.

Electrical Characteristics

VDD=1.8V, V1=0/1.8V, PIN=0dBm, TOP=+25°C, Z₀=50Ω. (unless otherwise noted)

PARAMETER		TEST CONDITION	MIN	TYP	MAX	UNIT
DC Specifications						
VDD	Supply Voltage		1.65	1.8	3.3	V
IDD	Supply Current			47	100	μA
VCTL_H	Control Voltage		1.35	1.8	3.3	V
VCTL_L	High Low		-0.3		0.45	
ICTL	Control Current	VCTL = 1.8V		0.1	1	μA
Tsw	Turn-on Switching Time	50% of final control voltage to 90% of final RF power, switching between RF1/2		1.0	2.0	μs
RF Specifications						
IL	Insertion loss	617-960MHz		0.24	0.33	dB
		960-2170 MHz		0.29	0.38	dB
		2170-2700 MHz		0.34	0.45	dB
		3300-3800 MHz		0.41	0.57	dB
		3800-5000 MHz		0.53	0.69	dB
		5150-5925 MHz		0.62	0.79	dB
ISO	Isolation	617-960MHz	37	45		dB
		960-2170 MHz	34	40		dB
		2170-2700 MHz	29	33		dB
		3300-3800 MHz	27	30		dB
		3800-5000 MHz	24	27		dB
		5150-5925 MHz	22	25		dB
RL	Input return loss	617-960MHz	23	28		dB
		960-2170 MHz	17	23		dB
		2170-2700 MHz	16	20		dB
		3300-3800 MHz	14	18		dB
		3800-5000 MHz	12	15		dB
		5150-5925 MHz	10	12		dB

PARAMETER	TEST CONDITION	MIN	TYP	MAX	UNIT
2fo	Second harmonics PIN=+35dBm, 915MHz,CW		-62	-52	dBm
3fo	Third harmonics PIN=+35dBm, 915MHz,CW		-58	-50	dBm
P0.1dB	0.1dB Compression Point 0.1-6 GHz		38		dBm

Power ON and OFF Sequence

It is very important that the user adheres to the correct power-on/off sequence in order to avoid damaging the device. The control signal V1 should be set to 0V unless VDD is set in the operating voltage range.

Power ON:

- 1) Apply voltage supply --- VDD
- 2) Set Controls---V1
- 3) Apply RF input

Change switch position from one RF port to another:

- 1) Remove RF input
- 2) Change control voltages V1 to set the switch to desired RF port
- 3) Apply RF input

Power OFF:

- 1) Remove RF input
- 2) Remove control voltages-V1
- 3) Remove VDD input

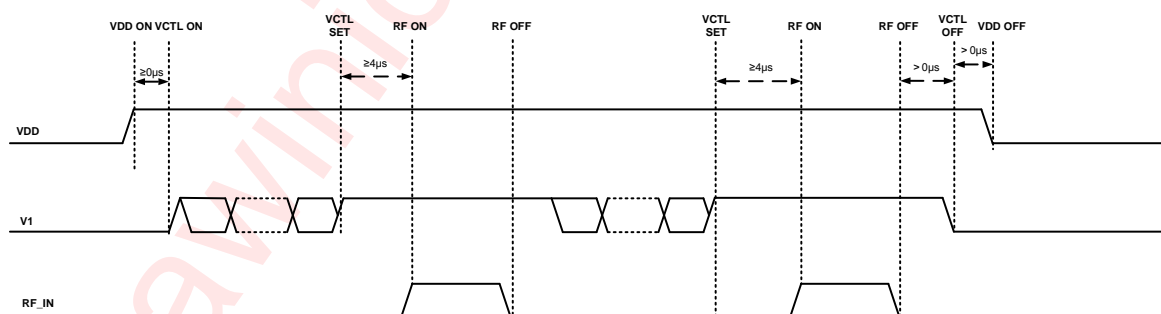
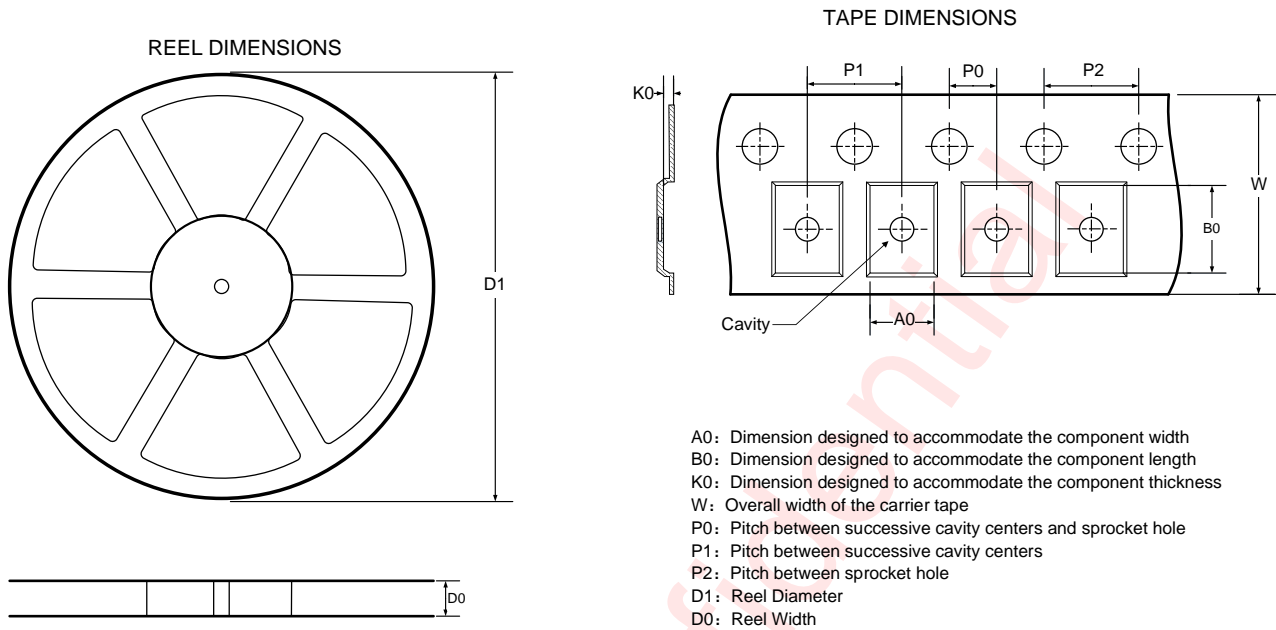

Figure 4 Power on/Change switch/Power off sequence

AW13612FLR Control Logic

State	Active Path	V1
0	ANT to RF1	0
1	ANT to RF2	1

Tape And Reel Information



QUADRANT ASSIGNMENTS FOR PIN 1 ORIENTATION IN TAPE

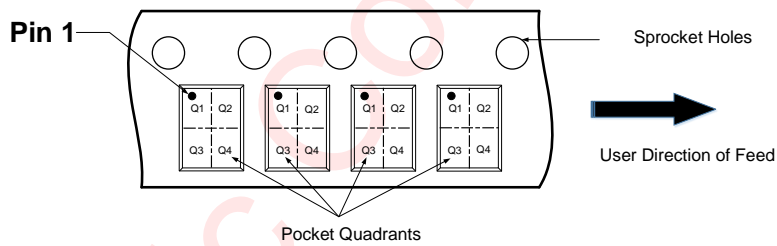

DIMENSIONS AND PIN1 ORIENTATION

D1 (mm)	D0 (mm)	A0 (mm)	B0 (mm)	K0 (mm)	P0 (mm)	P1 (mm)	P2 (mm)	W (mm)	Pin1 Quadrant
180	8.4	0.8	1.2	0.56	2	4	4	8	Q1

All dimensions are nominal

Figure 5 Tape and Reel

Package Description

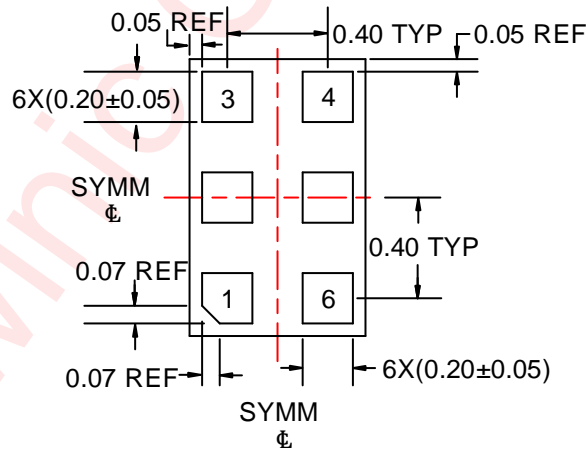
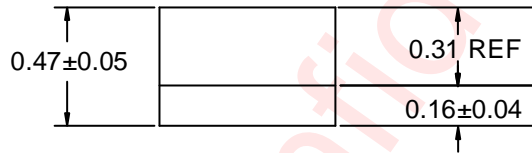
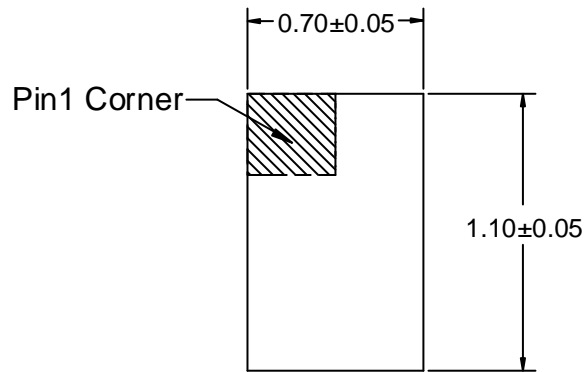

Unit:mm

Figure 6 Package Outline

Land Pattern Data

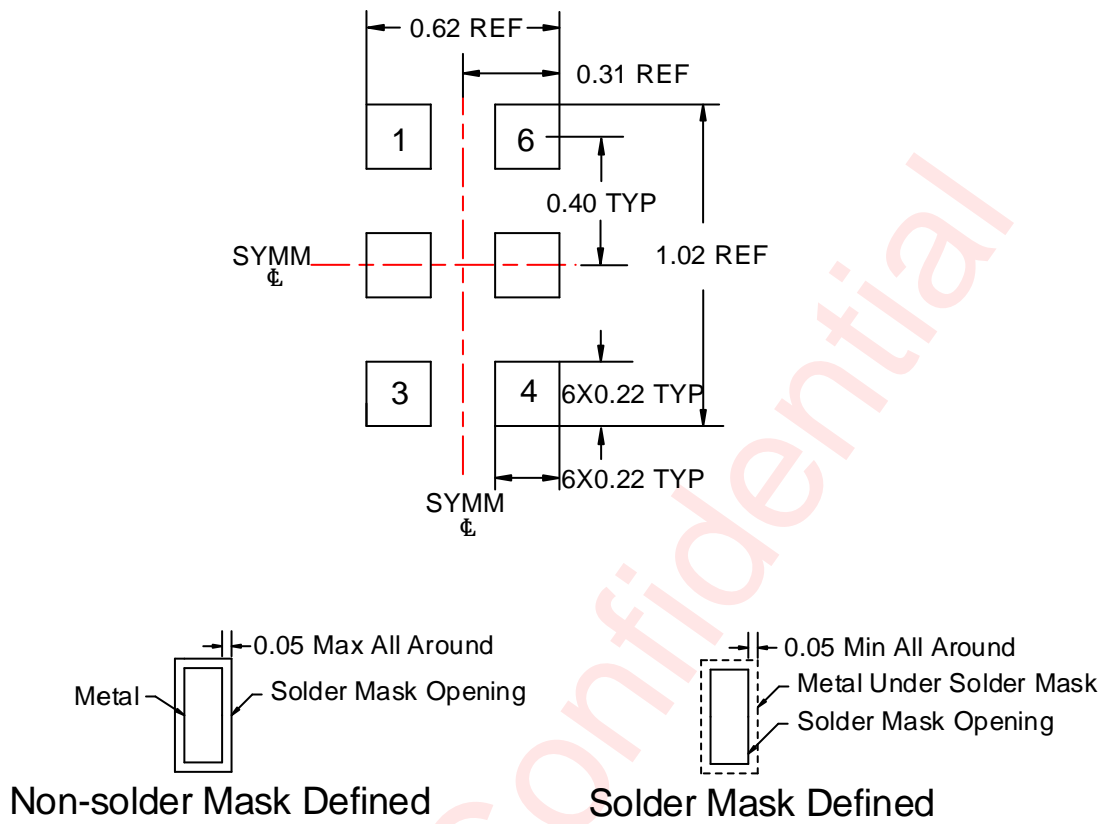

Unit: mm

Figure 7 Land Pattern Data

Revision History

Version	Date	Change Record
V1.0	Nov. 2020	Officially Released

awinic Confidential

Disclaimer

All trademarks are the property of their respective owners. Information in this document is believed to be accurate and reliable. However, Shanghai AWINIC Technology Co., Ltd (AWINIC Technology) does not give any representations or warranties, expressed or implied, as to the accuracy or completeness of such information and shall have no liability for the consequences of use of such information.

AWINIC Technology reserves the right to make changes to information published in this document, including without limitation specifications and product descriptions, at any time and without notice. Customers shall obtain the latest relevant information before placing orders and shall verify that such information is current and complete. This document supersedes and replaces all information supplied prior to the publication hereof.

AWINIC Technology products are not designed, authorized or warranted to be suitable for use in medical, military, aircraft, space or life support equipment, nor in applications where failure or malfunction of an AWINIC Technology product can reasonably be expected to result in personal injury, death or severe property or environmental damage. AWINIC Technology accepts no liability for inclusion and/or use of AWINIC Technology products in such equipment or applications and therefore such inclusion and/or use is at the customer's own risk.

Applications that are described herein for any of these products are for illustrative purposes only. AWINIC Technology makes no representation or warranty that such applications will be suitable for the specified use without further testing or modification.

All products are sold subject to the general terms and conditions of commercial sale supplied at the time of order acknowledgement.

Nothing in this document may be interpreted or construed as an offer to sell products that is open for acceptance or the grant, conveyance or implication of any license under any copyrights, patents or other industrial or intellectual property rights.

Reproduction of AWINIC information in AWINIC data books or data sheets is permissible only if reproduction is without alteration and is accompanied by all associated warranties, conditions, limitations, and notices. AWINIC is not responsible or liable for such altered documentation. Information of third parties may be subject to additional restrictions.

Resale of AWINIC components or services with statements different from or beyond the parameters stated by AWINIC for that component or service voids all express and any implied warranties for the associated AWINIC component or service and is an unfair and deceptive business practice. AWINIC is not responsible or liable for any such statements.