

DPDT USB Switch With Over Voltage Protection

Features

- USB 2.0 Hi-speed DPDT switch
- Typical -3dB bandwidth: 1.0 GHz
- Over voltage protection : 4.8V typical
- 20V DC protection on D+ and D- Ports
- +25V surge protection on D+ and D-
- Supply voltage range: 2.7V to 5.5V
- 5Ω switch on-resistance typical
- C_{ON}: 6pF typical
- I_{CC}: 35μA typical
- FCQFN 1.5mm X2.0mm X0.55mm-10L package

Applications

- Smartphones
- Tablets

General Description

The AW35742 is a Hi-Speed USB 2.0(480Mbps) DPDT (Double Pole Double Throw) switch with integrated protection for USB D+ and D-, it can be configured as a dual 1:2 or 2:1 switch.

The AW35742 protection on the D+/D- pins can tolerate up to 20V DC, when D+ or D- voltage is greater than the OVP(Over-Voltage Protection) threshold, the switch will be automatically shutoff to protect downstream devices.

The device operates over 2.7V to 5.5V supply range.

The AW35742 is available in an FCQFN 1.5mm X2.0mm X0.55mm-10L package.

Typical Application Circuit

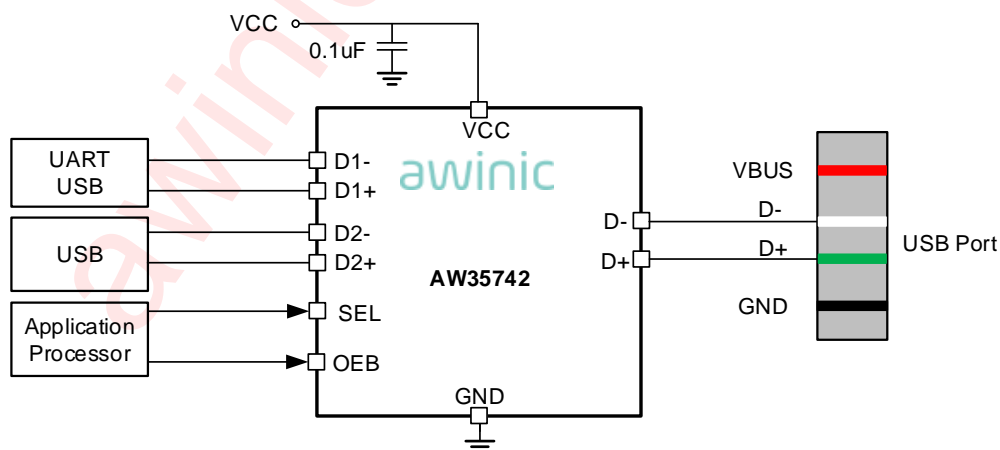

Typical Application Circuit of AW35742

All the trademarks mentioned in the document are the property of their owners.

Pin Configuration And Top Mark

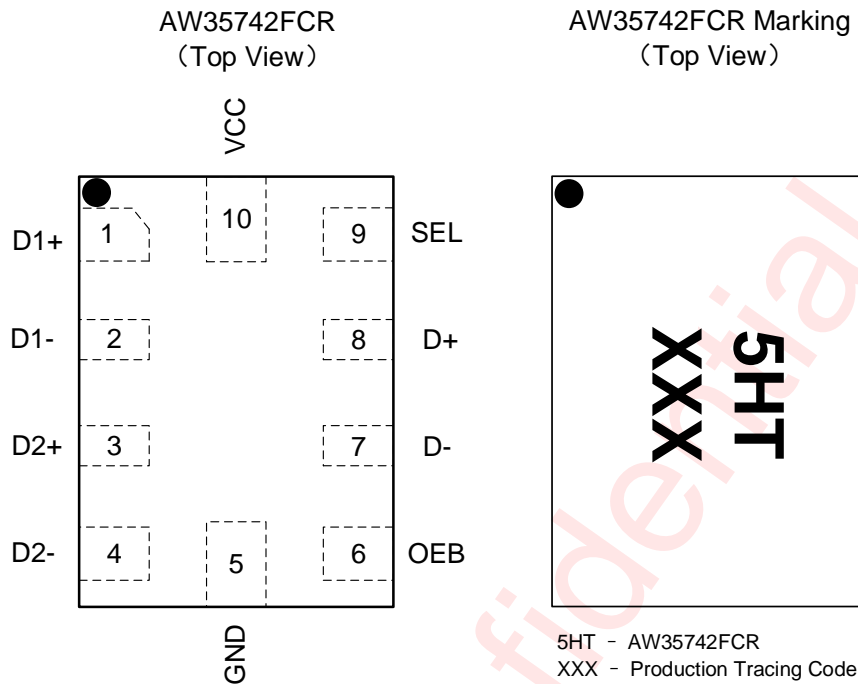

Pin Configuration And Top Mark

Pin Definition

No.	NAME	DESCRIPTION
1	D1+	Multiplexed high speed data port1, differential +
2	D1-	Multiplexed high speed data port1, differential -
3	D2+	Multiplexed high speed data port2, differential +
4	D2-	Multiplexed high speed data port2, differential -
5	GND	Ground
6	OEB	Output enable, active low
7	D-	Common high speed data port, differential -
8	D+	Common high speed data port, differential +
9	SEL	Switch select(logic Low = D+/- to D1+/- ,logic High = D+/- to D2+/-)
10	VCC	Supply voltage

Pin Functions

OEB	SEL	D- CONNECTION	D+ CONNECTION
H	X	High-Z	High-Z
L	L	D- to D1-	D+ to D1+
L	H	D- to D2-	D+ to D2+

Functional Block Diagram

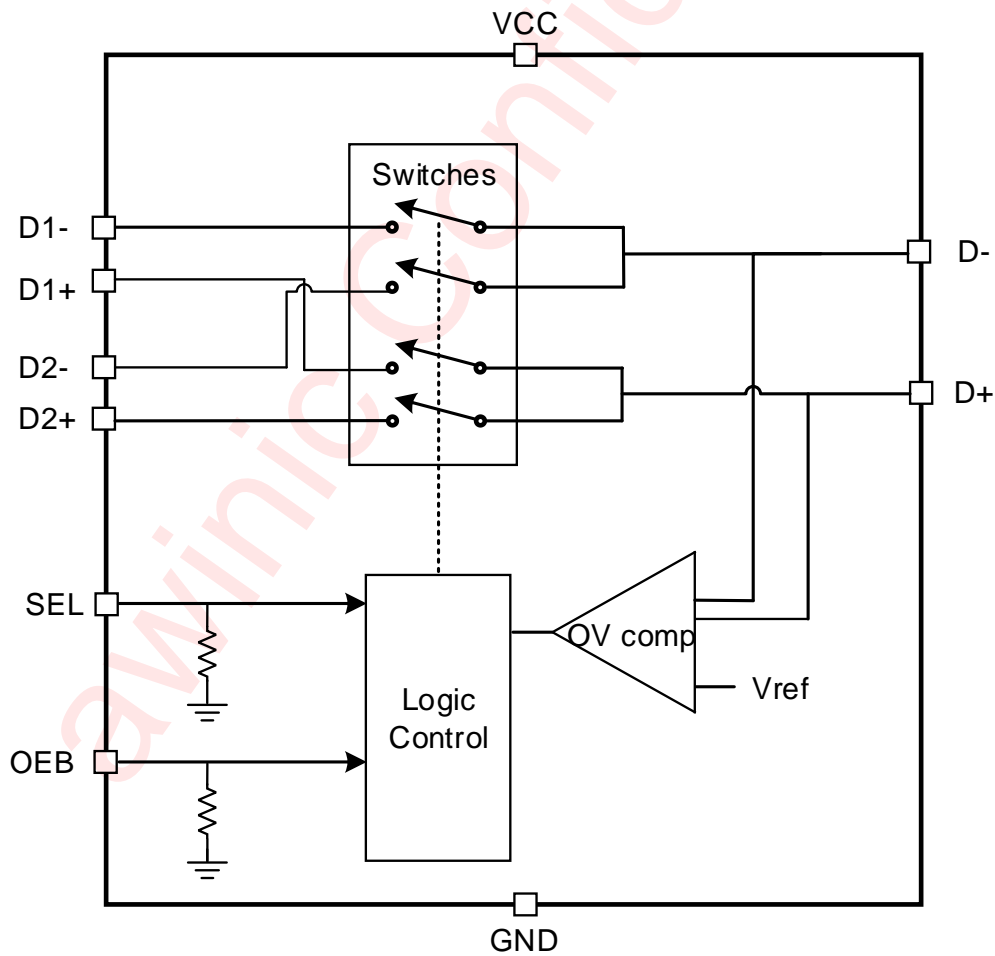

Functional Block Diagram

Typical Application Circuits

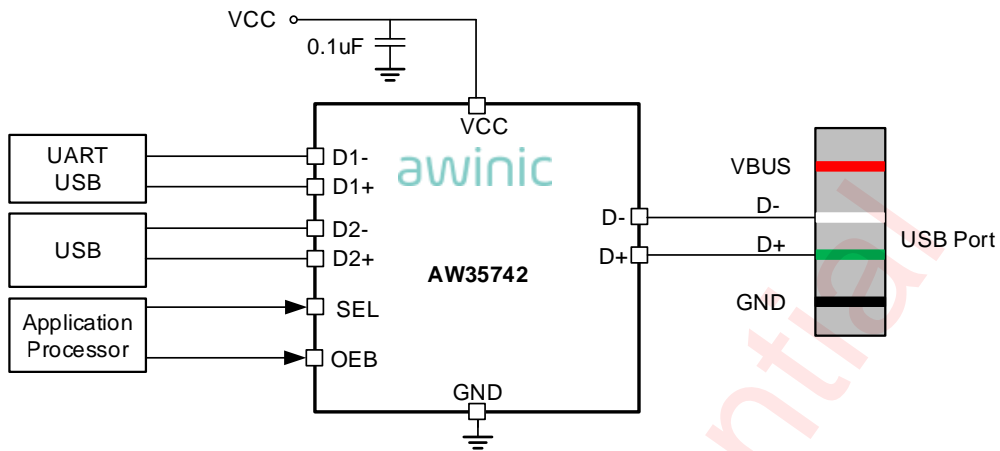

Typical Application Circuit of AW35742

Notice for Typical Application Circuits:

1. The AW35742 has internal 7-M Ω pull down resistors on SEL and OEB, so no external resistors are required on the logic pins.
2. Internal pull-down resistor on SEL pins ensures the D1+ and D1- channels are selected by default.

Ordering Information

Part Number	Temperature	Package	Marking	Moisture Sensitivity Level	Environmental Information	Delivery Form
AW35742FCR	-40°C~85°C	FCQFN 1.5mm X2.0mm -10L	5HT	MSL1	ROHS+HF	3000 units/ Tape and Reel

Absolute Maximum Ratings(NOTE1)

PARAMETERS		RANGE
Supply voltage range VCC		-0.3V to 6V
Input/Output DC voltage(D+, D-)		-0.3V to 20V
Input/Output DC voltage(D1+, D1-, D2+, D2-)		-0.3V to 6V
Input voltage range	SEL, OEB	-0.3V to 6V
Junction-to-ambient thermal resistance θ_{JA}		95°C/W
Maximum operating junction temperature T_{JMAX}		150°C
Operating free-air temperature range		-40°C to 85°C
Storage temperature T_{STG}		-65°C to 150°C
Lead temperature (soldering 10 seconds)		260°C
ESD		
Human Body Model (All pins, per JEDEC JS-001)		±2kV
Charged Device Model (All pins, per JEDEC JS-002)		±1.5kV
Latch-Up		
Test condition: JESD78E		±200mA

NOTE1: Conditions out of those ranges listed in "absolute maximum ratings" may cause permanent damages to the device. In spite of the limits above, functional operation conditions of the device should within the ranges listed in "recommended operating conditions". Exposure to absolute-maximum-rated conditions for prolonged periods may affect device reliability.

Electrical Characteristics

T_A = -40°C to 85°C unless otherwise noted. Typical values are guaranteed for V_{CC}=3.3V T_A = 25°C.

PARAMETER		TEST CONDITION	MIN	TYP	MAX	UNIT
V _{CC}	Supply voltage		2.7	3.3	5.5	V
I _{CC}	Active supply current	OEB=0V SEL =0V 0V < V _{D±} < 3.6V		35	50	μA
I _{CC_PD}	Standby supply current	OEB= V _{CC} SEL= 0V		9.5		μA
DC Characteristics						
R _{ON}	On-state resistance	V _{I/O} =0.4V, I _{SINK} =8mA		5		Ω
ΔR _{ON}	On-state resistance match between channels	V _{I/O} =0.4V, I _{SINK} =8mA		0.1		Ω
R _{ON(FLAT)}	ON-state resistance flatness	V _{I/O} =0V to 0.4V, I _{SINK} =8mA		0.1		Ω
I _{OFF}	I/O pin OFF leakage current on D+/D-	V _{D±} = 0 V or 3.6 V V _{D1±} or V _{D2±} = 3.6 V or 0 V			10	μA
I _{ON}	ON leakage current on D+/D-	V _{D±} = 0 V or 3.6 V V _{D1±} and V _{D2±} = high-Z		2	10	μA
Digital Characteristics						
V _{IH}	Input logic high	SEL, OEB	1.4			V
V _{IL}	Input logic low	SEL, OEB			0.4	V
R _{PD}	Internal pull-down resistor on digital input pins			7		MΩ
Protection						
V _{OVP_TH}	OVP threshold	D+/D- rising	4.4	4.8	5.4	V
V _{OVP_HYST}	OVP threshold hysteresis			60		mV
V _{CLAMP_V}	Clamping voltage on D _{1±} and D _{2±} pins during surge	8/20 μs surge test, OEB=0V, R _L = open			9	V
t _{CLAMP}	Clamp time during OVP	8/20 μs surge test, OEB=0V, R _L = open		2	5	μs

Electrical Characteristics (Continued)

T_A = -40°C to 85°C unless otherwise noted. Typical values are guaranteed for V_{CC}=3.3V T_A = 25°C.

PARAMETER	TEST CONDITION	MIN	TYP	MAX	UNIT	
Dynamic Characteristics						
C _{ON}	IO pins ON capacitance	V _{D±} = 0 or 3.3 V, f = 240 MHz, switch ON		6	pF	
O _{ISO}	Differential off isolation	R _L = 50 Ω C _L = 5 pF f = 100 kHz, switch OFF		-60	dB	
		R _L = 50 Ω C _L = 5 pF f = 240MHz, switch OFF		-20	dB	
X _{TALK}	Channel to channel crosstalk	R _L = 50 Ω C _L = 5 pF f = 100 kHz, switch ON		-60	dB	
BW	-3dB bandwidth	R _L = 50 Ω, switch ON		1.0	GHz	
t _{switch}	Switching time between channels (SEL1, SEL2 to output)	V _{D±} = 0.8 V R _L = 50 Ω		1.5	5	μs
t _{on}	Device turn on time (OEB to output)	C _L = 5 pF, V _{CC} = 2.7 V to 5.5 V		15		μs
t _{off}	Device turn off time (OEB to output)			1.5		μs
t _{pd}	Propagation delay	V _{D±} = 0.4 V R _L = 50 Ω, C _L = 5 pF, V _{CC} = 2.7 V to 5.5 V		200		ps

Typical Characteristics

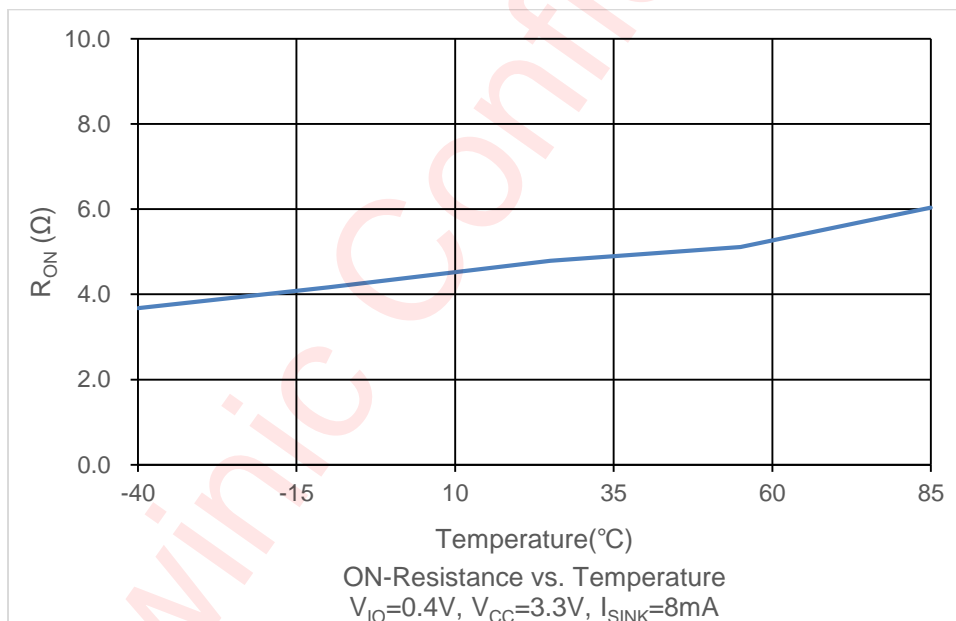
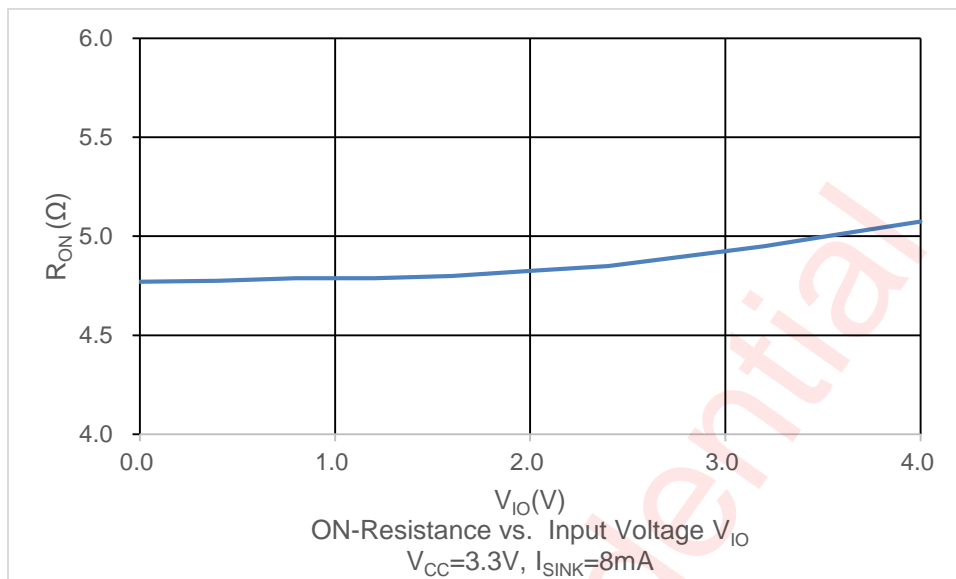

Detailed Functional Description

The AW35742 is a Hi-Speed USB 2.0 DPDT switch with integrated protection for USB D+ and D-, it can be configured as a dual 1:2 or 2:1 switch. The AW35742 will protect D+ and D- pins when stressed with voltages up to 20V. The device can pass signals with bandwidth 1GHz to maintain signal integrity and eye compliance.

Over-Voltage Protection

AW35742 is designed to protect the system from damage. Over-voltage event happens when voltage on D+/D- exceeds 4.8V(typ.), and device will activate OVP to disconnect the switches.

High Impedance Mode

When OEB is logic high, the AW35742 is in high impedance mode, all the signal paths are in Hi-Z state.

OEB	SEL	D- Connection	D+ Connection
H	X	High-Z	High-Z
L	L	D- to D1-	D+ to D1+
L	H	D- to D2-	D+ to D2+

PCB Layout Consideration

To obtain the optimal performance of AW35742, PCB layout should be considered carefully. Here are some guidelines:

1. Place supply bypass capacitors as close to VCC pin as possible and avoid placing the bypass capacitors near the D+/D- traces.
2. The differential characteristic impedance of D+ and D- traces is suggested to be 90Ω , and it's better to shield D+ and D- traces by ground planes.
3. Route the high-speed USB signals using a minimum of vias and corners which reduces signal reflections and impedance changes.
4. Do not route USB traces under or near crystals, oscillators, clock signal generators, switching regulators, mounting holes, magnetic devices or ICs that use or duplicate clock signals.
5. Avoid stubs on the high-speed USB signals because they cause signal reflections.
6. Route all high-speed USB signal traces over continuous GND planes, with no interruptions.

Package Description

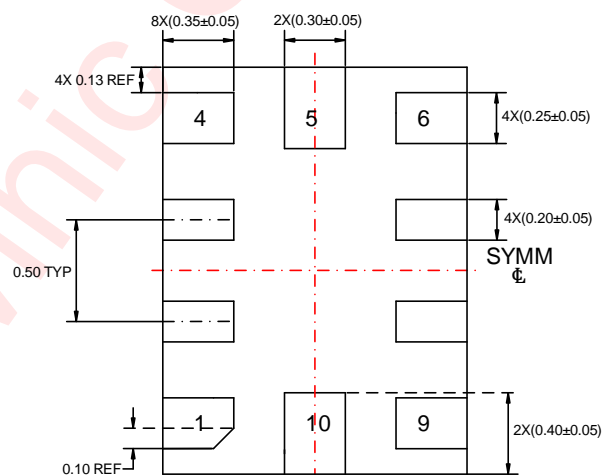
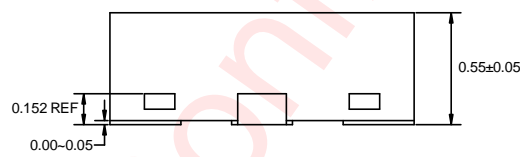
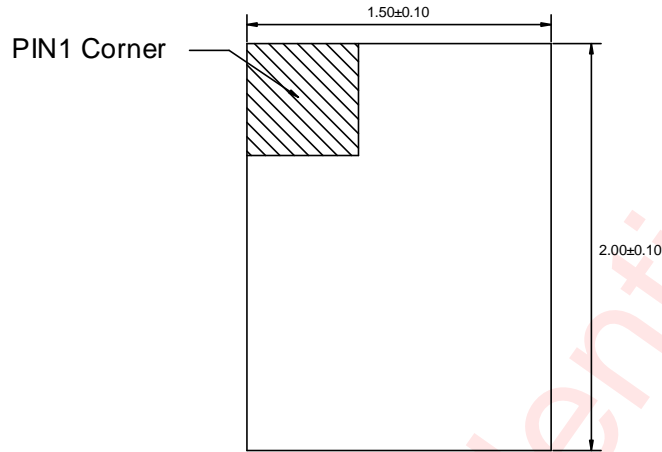

Unit: mm

Land Pattern Data

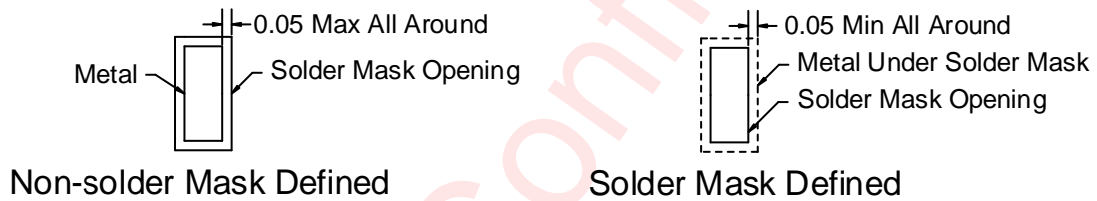
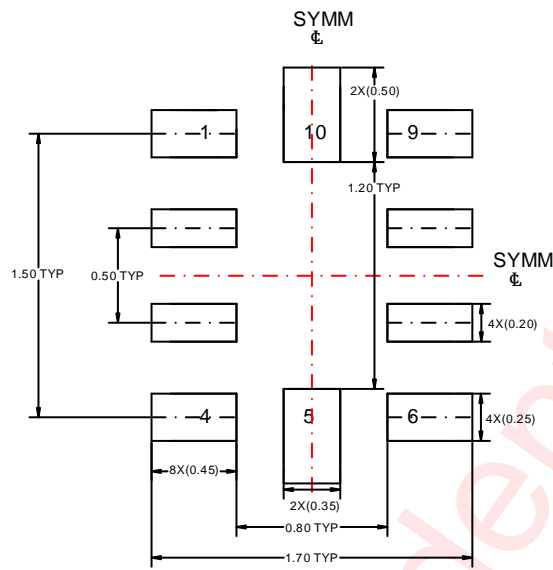

Unit: mm

Revision History

Version	Date	Change Record
V1.0	Feb. 2019	Datasheet V1.0 released
V1.1	Feb. 2020	Updated Description of SEL(P2) , D+/- MAX Voltage(P1,P5,P20)
V1.2	Aug. 2021	Updated Description of SEL,OEB(P6)

awinic Confidential

Disclaimer

Information in this document is believed to be accurate and reliable. However, Shanghai AWINIC Technology Co., Ltd (AWINIC Technology) does not give any representations or warranties, expressed or implied, as to the accuracy or completeness of such information and shall have no liability for the consequences of use of such information.

AWINIC Technology reserves the right to make changes to information published in this document, including without limitation specifications and product descriptions, at any time and without notice. Customers shall obtain the latest relevant information before placing orders and shall verify that such information is current and complete. This document supersedes and replaces all information supplied prior to the publication hereof.

AWINIC Technology products are not designed, authorized or warranted to be suitable for use in medical, military, aircraft, space or life support equipment, nor in applications where failure or malfunction of an AWINIC Technology product can reasonably be expected to result in personal injury, death or severe property or environmental damage. AWINIC Technology accepts no liability for inclusion and/or use of AWINIC Technology products in such equipment or applications and therefore such inclusion and/or use is at the customer's own risk.

Applications that are described herein for any of these products are for illustrative purposes only. AWINIC Technology makes no representation or warranty that such applications will be suitable for the specified use without further testing or modification.

All products are sold subject to the general terms and conditions of commercial sale supplied at the time of order acknowledgement.

Nothing in this document may be interpreted or construed as an offer to sell products that is open for acceptance or the grant, conveyance or implication of any license under any copyrights, patents or other industrial or intellectual property rights.

Reproduction of AWINIC information in AWINIC data books or data sheets is permissible only if reproduction is without alteration and is accompanied by all associated warranties, conditions, limitations, and notices. AWINIC is not responsible or liable for such altered documentation. Information of third parties may be subject to additional restrictions.

Resale of AWINIC components or services with statements different from or beyond the parameters stated by AWINIC for that component or service voids all express and any implied warranties for the associated AWINIC component or service and is an unfair and deceptive business practice. AWINIC is not responsible or liable for any such statements.