

200mA 1-Wire Configurable Front Flash LED Driver with Ultra Small Package

FEATURES

- Front Flash LED Driving
- 200mA Maximum LED Current
- 16 LED Current Levels Selectable by 1-wire Interface
- LED Current Accuracy: $\pm 8\%$
- Low Dropout Voltage: 50mV@200mA
- LED Short Protection
- Under Voltage Lock Out (UVLO)
- Over Thermal Protection(OTP)
- Ultra Small 1.5mm×1.0mm DFN-6 Package
Compatible with AW3640

APPLICATION

- Cell Phone

GENERAL DESCRIPTION

The AW36402 is a low voltage-drop current sink LED driver, which supports both flash and torch applications. The current-regulation sink integrated in the chip makes the LED current be capable of keeping constant when input voltage, LED forward voltage or temperature are changing. The LED current can be adjusted among 16 steps by sending 1-wire pulses into the EN pin, and the maximum value is 200mA.

The AW36402 is available in an ultra-small 1.5mm×1.0mm DFN-6 package, and only one multi-layer ceramic capacitor is needed for the peripheral of the solution.

In shut down mode, the AW36402 turns off all internal circuits and the consumption is less than 1 μ A.

The device requires 2.7V~5.5V input voltage range and an operating temperature range of -40~85 $^{\circ}$ C.

TYPICAL APPLICATION CIRCUIT

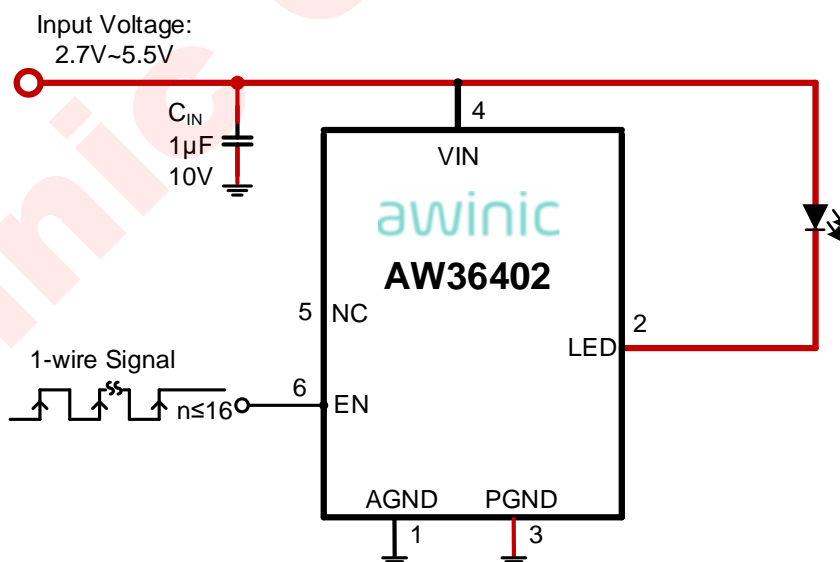
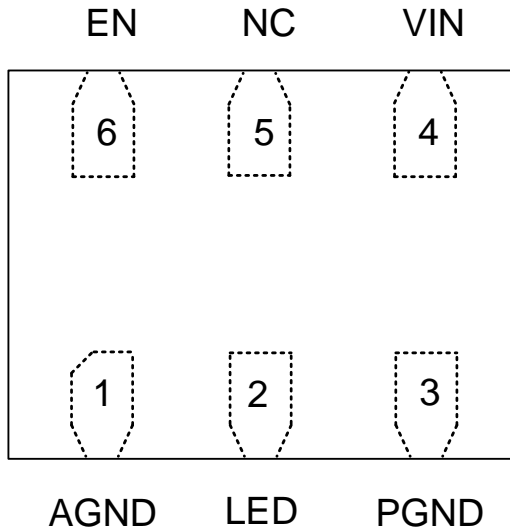
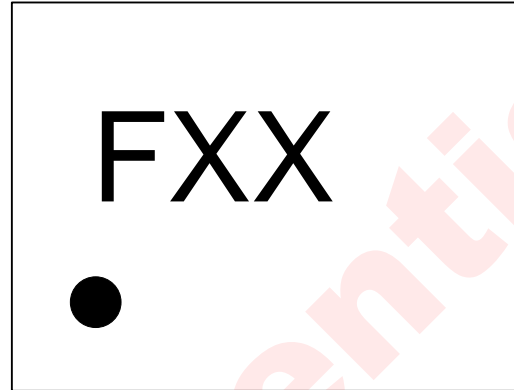

Figure 1. The AW36402 Application Circuit for Single LED

PIN CONFIGURATION AND TOP MARK**AW36402DNR Pin Configuration
(Top View)****AW36402DNR Marking
(Top View)**

F -- AW36402DNR
XX -- Production Tracking Code

Figure 2. The AW36402 Pin Configuration and Top Mark

PIN DEFINITION

No.	NAME	TYPE	DESCRIPTION
1	AGND	Ground	Analog Ground.
2	LED	I/O	Low-Side Current Sink Output for LED.
3	PGND	Ground	Power Ground.
4	VIN	Power	Power Supply (2.7V-5.5V).
5	NC	I/O	No Connect.
6	EN	I/O	Enable Pin. LED Current Can be Adjusted by Sending 1-wire Pulse into This Pin.

ORDERING INFORMATION

Part Number	Temperature	Package	Marking	Moisture Sensitivity Level	Environmental Information	Delivery Form
AW36402DNR	-40°C~85°C	DFN-6 1.5mm*1mm	FXX	MSL1	ROHS+HF	3000 units/ Tape and Reel

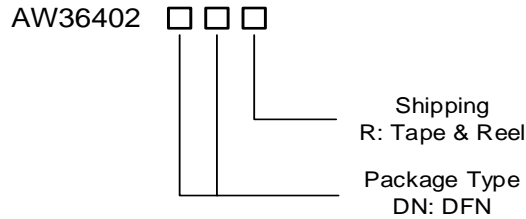

AWINIC FLASH LED DRIVER SERIES

Product	Channels	Type	Description	Package
AW3644	2	Boost	High Efficiency, Dual Independent 1.5A Flash LED Driver	CSP-12
AW36414	2	Boost	High Efficiency, Dual Independent 1.5A Flash LED Driver	CSP-12
AW3643	2	Boost	High Efficiency, Dual 1.5A Flash LED Driver	CSP-12
AW36413	2	Boost	High Efficiency, Dual 1.5A Flash LED Driver	CSP-12
AW3648	1	Boost	High Efficiency, 1.5A Flash LED Driver	CSP-12
AW3641E	1	Charge Pump	Flash Current & Flash Timer Programmable 1A Flash LED Driver	DFN-10
AW3640	1	Current Sink	200mA 1-Wire Configurable Front Flash LED Driver	DFN-6
AW36402	1	Current Sink	200mA 1-Wire Configurable Front Flash LED Driver	DFN-6
AW36404	1	Current Sink	400mA 1-Wire Configurable Front Flash LED Driver	DFN-8
AW36406	1	Current Sink	600mA PWM Configurable Front Flash LED Driver	DFN-8

TYPICAL APPLICATION CIRCUIT

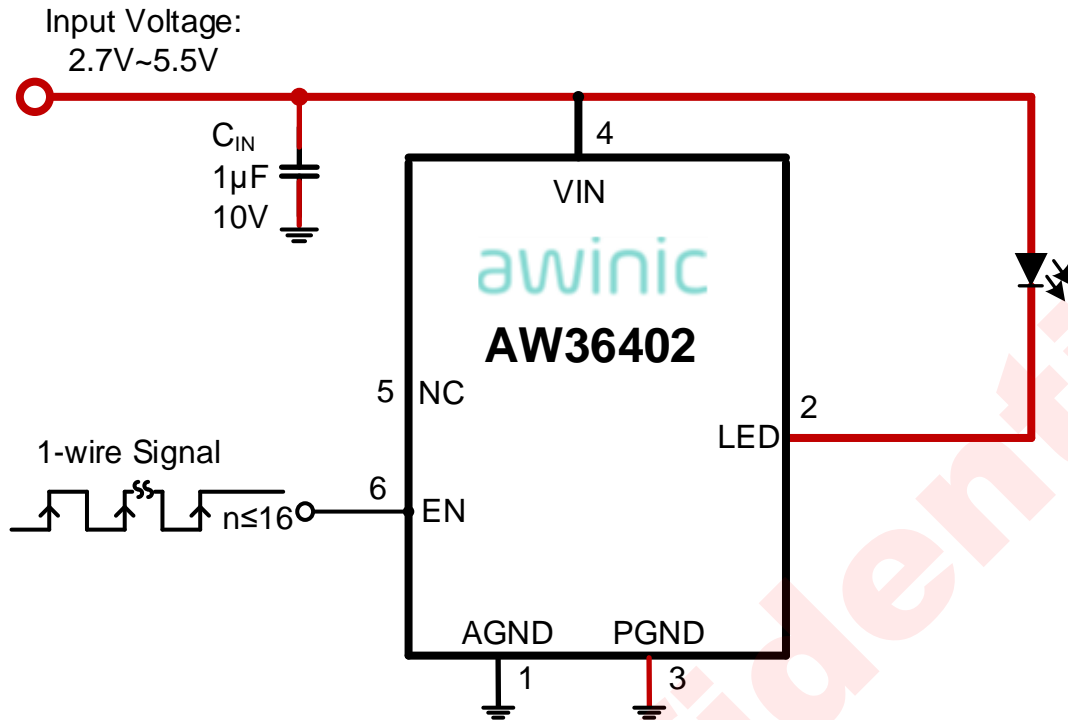

Figure 3. Application Circuit for Single LED

Notice for Typical Application Circuits:

1. C_{IN} should be close to the pin of VIN.
2. Red line is high current path. Considering driving ability, for example, the power path INPUT--VIN--LED should be as short and wide as possible.
3. For better thermal performance and noise performance, GND pins (PIN1, and PIN3) should be connected directly to a large area of the PCB ground plane.

ABSOLUTE MAXIMUM RATINGS^(NOTE1)

PARAMETERS		Range	Unit
VIN, LED		-0.3 to 6	V
EN		-0.3 to (VIN+0.3)	V
Max Junction Temperature T _{JMAX}		155	°C
Storage Temperature T _{STG}		-65 to 150	°C
Maximum lead temperature (soldering)		260	°C
Junction to Ambient Thermal Resistance θ_{JA}		142	°C/W
ESD, All Pins ^(NOTE2)	HBM	±2000	V
	MM	±200	V
	CDM	±2000	V
Latch-Up JEDEC STANDARD NO.78B DECEMBER 2008		+IT: +350 -IT: -350	mA

RECOMMENDED OPERATING CONDITIONS

PARAMETERS		Range	Unit
VIN		2.7 to 5.5	V
Junction temperature (T _J)		-40 to 125	°C
Ambient temperature (T _A)		-40 to 85	°C

NOTE1: Conditions out of those ranges listed in “absolute maximum ratings” may cause permanent damages to the device. In spite of the limits above, functional operation conditions of the device should within the ranges listed in “recommended operating conditions”. Exposure to absolute-maximum-rated conditions for prolonged periods may affect device reliability.

NOTE2: The human body model is a 100pF capacitor discharged through a 1.5k Ω resistor into each pin. Test method: MIL-STD-883G Method 3015.7

ELECTRICAL CHARACTERISTICS

VIN=3.6V, TA=25°C for typical values (unless otherwise noted)。

Symbol	Description	Test Conditions	Min	Typ	Max	Units
Power supply						
VIN	Input Operation Voltage		2.7		5.5	V
UVLO	Input Under Voltage Lock Out	Rising edge		2.4		V
		Falling edge	1.9	2.2	2.5	V
ISD	Current In Shutdown Mode	EN=0		0.1	1	μA
IQ	Quiescent Current	EN=1, LED pin open		160		μA
LED Driver						
I _{LED}	Total Output Current, Flash/Torch Mode	Step NUM=1	-8%	200	8%	mA
V _{DROP}	Dropout Voltage	I _{LED} =200mA		50	125	mV
I _{SHORT}	LED Short Detecting Current			2.5		mA
T _{SOFTSTART}	Current Rising Time			200		μs
Control						
V _{IL}	Logic Input Low Level				0.4	V
V _{IH}	Logic Input High Level		1.3			V
R _{EN}	Pull Down Resistor Inside			500		kΩ
T _{SD}	Thermal Shutdown Threshold			155		°C
	Thermal Shutdown Hysteresis			20		°C
1-Wire Dimming Pulse Timing						
T _{LO}	EN Pulse Low Time		0.5	2	10	μs
T _{HI}	EN Pulse High Time		0.5	2	10	μs
T _{ON_DELAY}	Time Between EN Pulled To High and Soft-Start			350	450	μs
T _{SHDN}	Chip Shutdown Delay	Measure from EN falling edge to the chip entering into shut down mode	0.5		2.5	ms

TYPICAL CHARACTERISTICS

VIN=3.6V, TA=25°C, Unless otherwise noted.

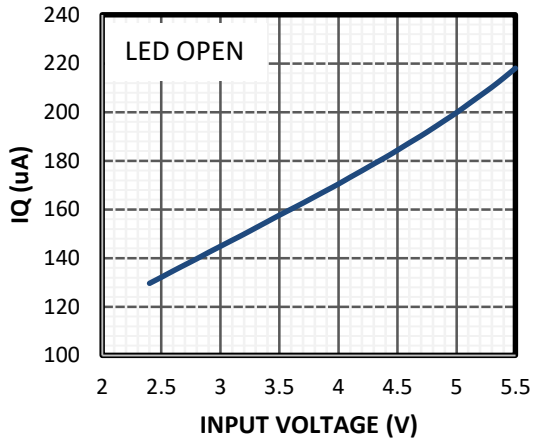

Figure 4. Quiescent Current

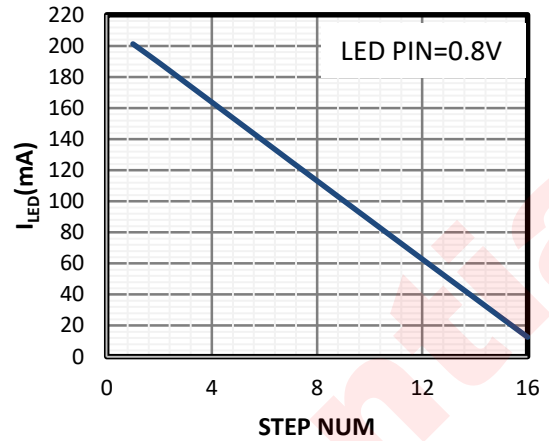

Figure 5. LED Current vs Step Num

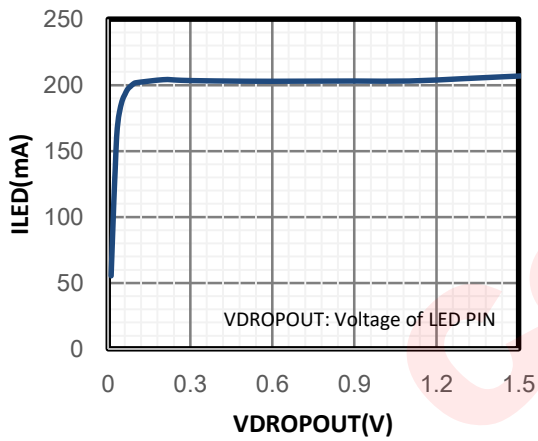

Figure 6. LED Current vs Dropout Voltage

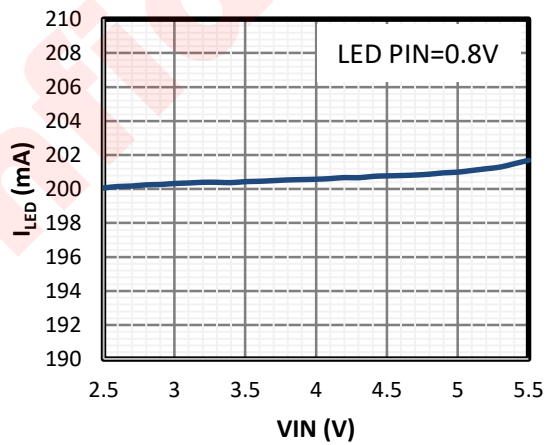

Figure 7. LED Current vs VIN

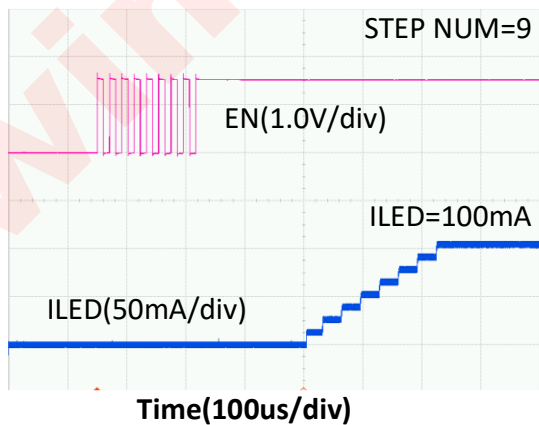

Figure 8. Startup Wave

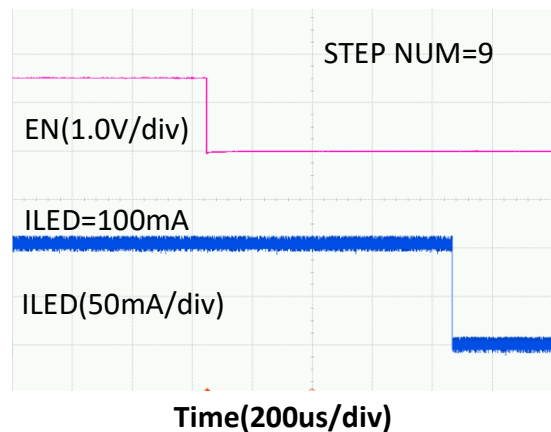

Figure 9. Shutdown Wave

FUNCTION BLOCK

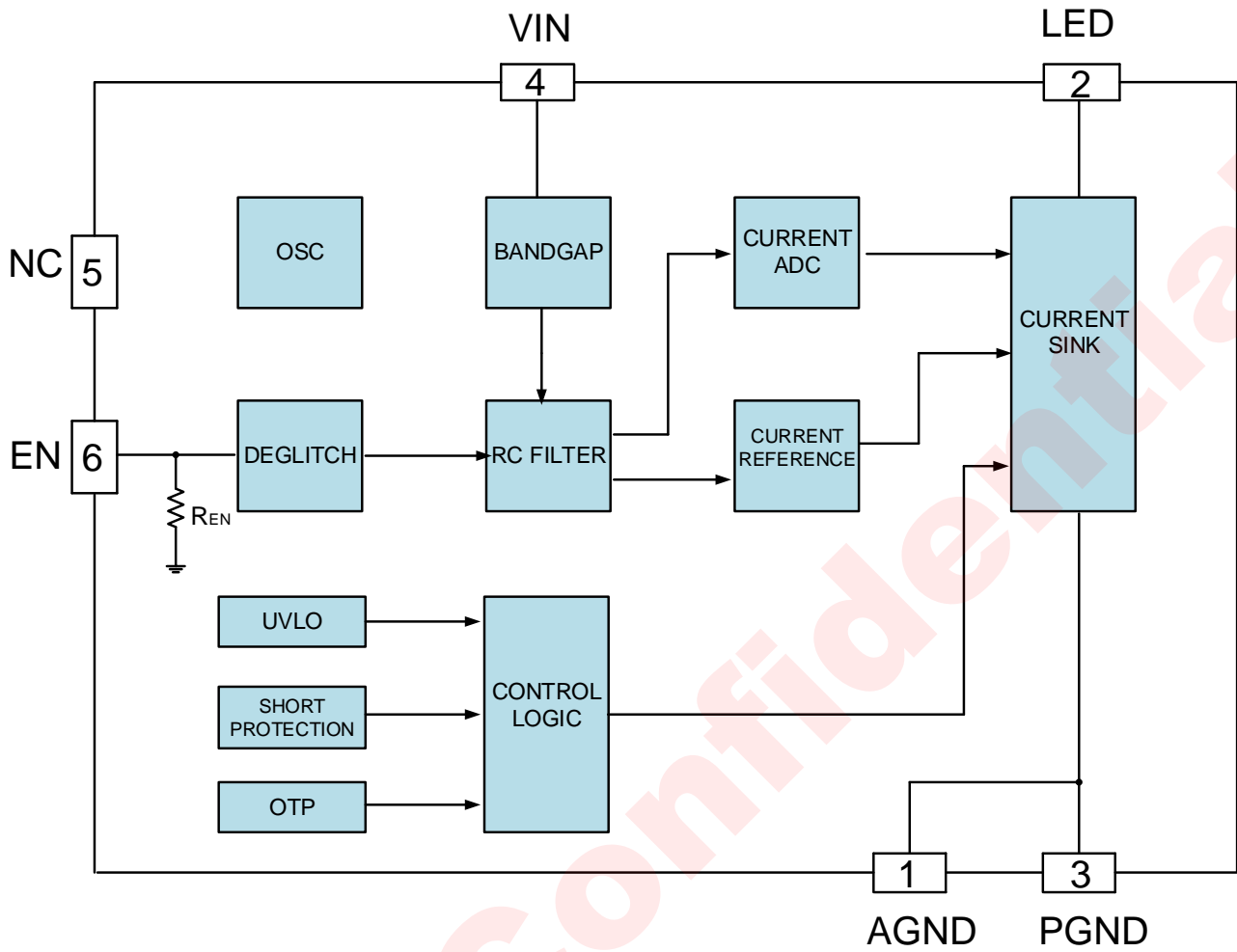

Figure 10. The AW36402 Function Block

DETAILED DESCRIPTION

The AW36402 is a low voltage-drop current sink LED driver, which supports both flash and torch applications. The current-regulation sink integrated in the chip makes the LED current capable of keeping constant when input voltage, LED forward voltage or temperature are changing. The LED current can be adjusted among 16 steps by sending 1-wire pulse into the EN pin, and the maximum value is 200mA.

EN Control

The voltage level at EN pin determines the operation state of the chip. When the EN pin is set to high, the AW36402 operates in normal state. And the chip would enter shutdown mode if the EN pin is set to low for over 2.5ms, as a built-in shutdown delay circuit in the AW36402. The shutdown current dissipated by the AW36402 is less than 1 μ A.

The AW36402 built in deglitch circuit. The interference between signals inside the portable device is unavoidable, thus deglitch circuit is necessary at the EN pin. The deglitch circuit inside the AW36402 is capable of eliminating the glitch which is narrower than 80ns, preventing the incorrect trigger at the EN pin effectively.

Soft-Start

To decrease VBAT voltage fluctuation caused by inrush current, the AW36402 built in soft-start function. It takes 8 steps to ramp up to setting current and the ramp time is about 200 μ s.

UVLO

The device has under voltage lock-out (UVLO) function to monitor the input voltage. Once the input voltage VIN drops below UVLO falling threshold (around 2.2V), the output current is disabled. Once the input voltage increases above UVLO rising threshold (around 2.4V), the output current resumes its previous setting.

LED Short Protection

Short protection function will be enabled after the 1st step of soft-start. The IC internally compares the voltage difference between VIN and the sink node (LED pin) with a preset threshold. If this difference is below the preset threshold, AW36402 will treat the LED as shorted and disable its Flash/Torch mode current through the LED pin. However, a 2.5mA detecting current will be kept to generate the LED's voltage drop. Because some normal flash LEDs may have larger than desired leakage current (up to hundreds of micro-amps) even if it's not fully turned on, this 2.5mA sensing current can guarantee that a properly functioning LED will not mistakenly be treated as a shorted LED. If the short circuit is removed during operation, the LED will automatically recover to the programmed current setting.

Thermal Shutdown

In flash or torch mode, the device has thermal shutdown protection, when the IC temperature goes above thermal shutdown rising threshold (around 155 $^{\circ}$ C), the output current is disabled. There are 2 conditions should be satisfied at the same time to resume output current: one is the IC temperature drops below thermal shutdown falling threshold (around 135 $^{\circ}$ C); the other is that the chip is reset through EN.

APPLICATION INFORMATION

1-Wire Pulse Dimming

The AW36402 adopts the 1-wire pulse dimming to avoid the switch noise. A 4-bit DAC inside the AW36402 allows counting the rising edge at the EN pin to set the LED current (refer to Figure 11). Figure 11 shows that high level time $0.5\mu\text{s} < T_{\text{HI}} < 10\mu\text{s}$; and low level time $0.5\mu\text{s} < T_{\text{LO}} < 10\mu\text{s}$. If high time of EN is larger than $T_{\text{ON_DELAY}}$, then LED current will start to ramp up to setting value. But if add another pulse after soft-start, LED current will be changed to a new setting value directly. If low time of EN is larger than T_{SHDN} , then the AW36402 will be shut down.

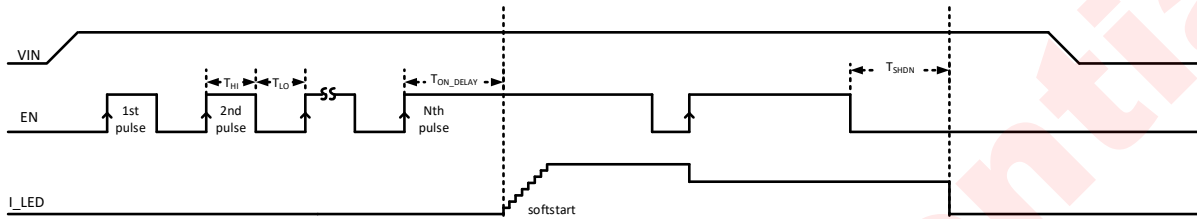

Figure 11. The AW36402 1-wire Dimming Timing Diagram

The LED current steps down along with the increasing EN pulse rising edge number. After the current setting process, the EN pin should set to high level.

LED current can be calculate as below:

$$I_{\text{LED}} \approx 12.5\text{mA} * (17 - N)$$

N is number of EN pulse rising edge. N is integer and changed from 1 to 16. Please note that every 16 pulses is a cycle when $N > 16$.

Efficiency

The AW36402 is a low voltage-drop current sink LED driver, its operation efficiency can be approximately calculated as below.

$$\eta = \frac{P_{\text{OUT}}}{P_{\text{IN}}} = \frac{V_F \times I_{\text{OUT}}}{V_{\text{IN}} \times I_{\text{IN}}} \approx \frac{V_F \times I_{\text{OUT}}}{V_{\text{IN}} \times I_{\text{OUT}}} = \frac{V_F}{V_{\text{IN}}}$$

V_F in the formula represents the forward voltage of LED. If V_{IN} is 3.6V, V_F is 3.4V, the chip efficiency is about 94%.

PCB LAYOUT CONSIDERATION

To make fully use of the performance of the AW36402, the guidelines below should be followed:

1. All the peripherals should be placed as close to the device as possible. Place the input capacitor C_{IN} on the top layer (same layer as the AW36402) and close to VIN (pin4).
2. Route the power line (shown in Figure 3) as widely and shortly as possible to reduce parasitic impedance.
3. To optimize the heat dissipation performance, the GND pins (pin1 & 3) should be connected to the PCB ground plane using as many vias as possible.

TAPE AND REEL INFORMATION

Carrier Tape

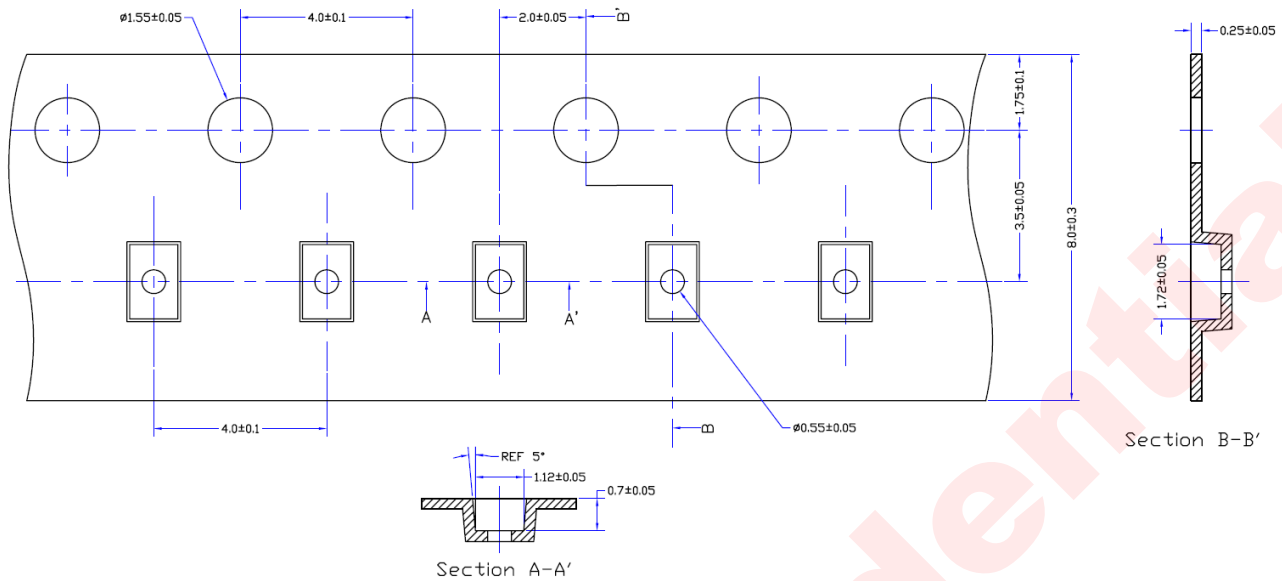

NOTES:

1. 10 pocket hole pitch cumulative tolerance ± 0.2 .
2. The meander of tape is assumed with 1mm or less every 100mm between 250mm.
3. Material: CONDUCTIVE POYSTYRENE.
4. All DIMS in MM.
5. Surface resistance $1 \times 10^{11}(\text{max})$ OHMS/SQ612-UDFN1.5*1.0.

Pin 1

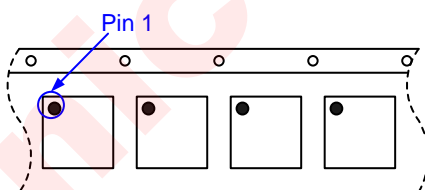

User Direction of Feed

Reel

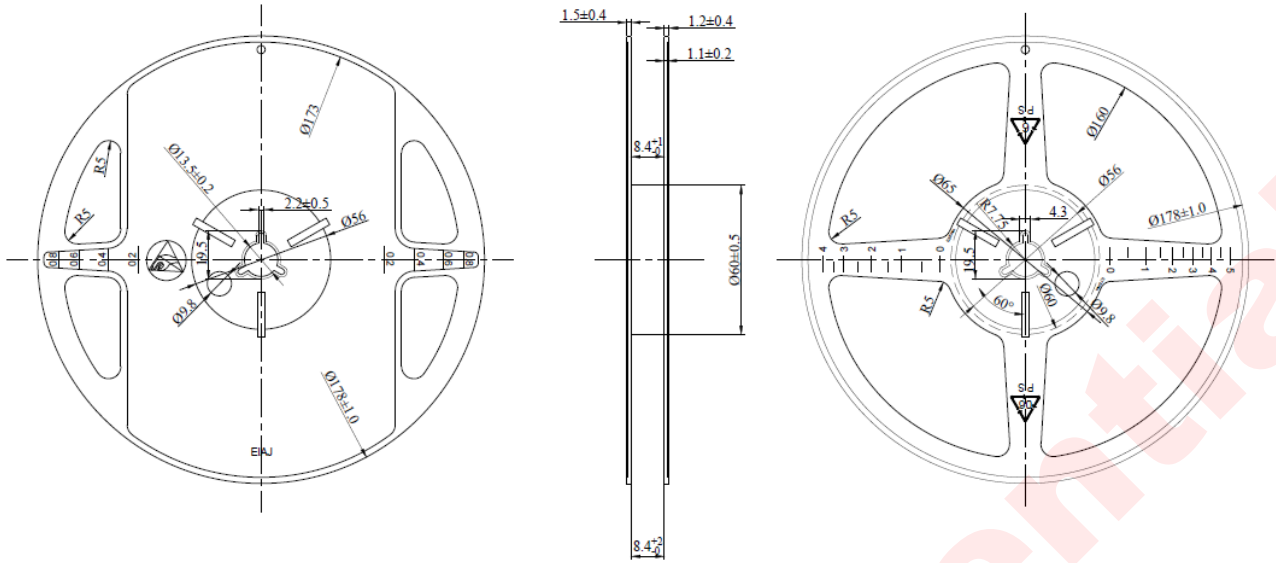

NOTE:

1. All DIMS in mm.
2. General tolerance $\pm 0.25\text{mm}$.
3. Material: Dissipative.
4. Flange warpage: 3mm maximum.
5. Surface resistivity : $10\text{E}5\sim 10\text{E}11$ OHMS/SQ.

PACKAGE INFORMATION

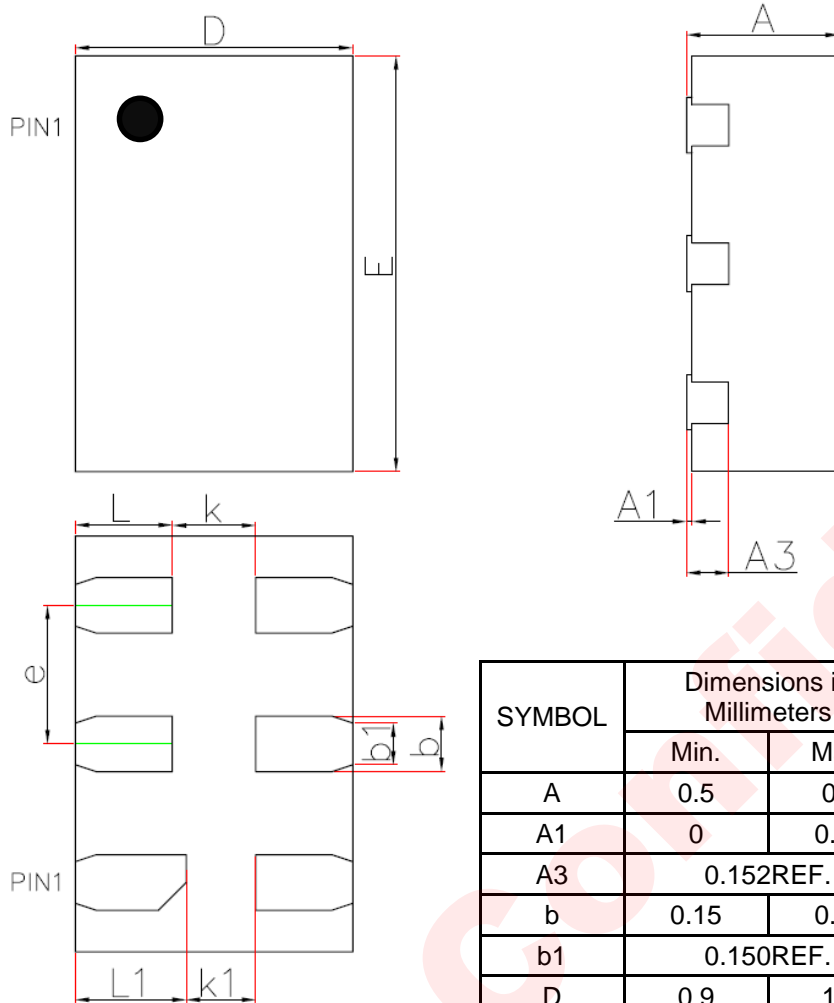

SYMBOL	Dimensions in Millimeters		Dimensions in Inches	
	Min.	Max.	Min.	Max.
A	0.5	0.6	0.02	0.024
A1	0	0.05	0	0.002
A3	0.152REF.		0.006REF.	
b	0.15	0.25	0.006	0.01
b1	0.150REF.		0.006REF.	
D	0.9	1.1	0.035	0.043
E	1.4	1.6	0.055	0.063
e	0.500BSC.		0.020BSC.	
k	0.300REF.		0.012REF.	
k1	0.250REF.		0.010REF.	
L	0.3	0.4	0.012	0.016
L1	0.35	0.45	0.014	0.018

NOTE:

- 1、 All DIMS in mm.
- 2、 General Tolerance $\pm 0.25\text{mm}$.

LAND PATTERN EXAMPLE

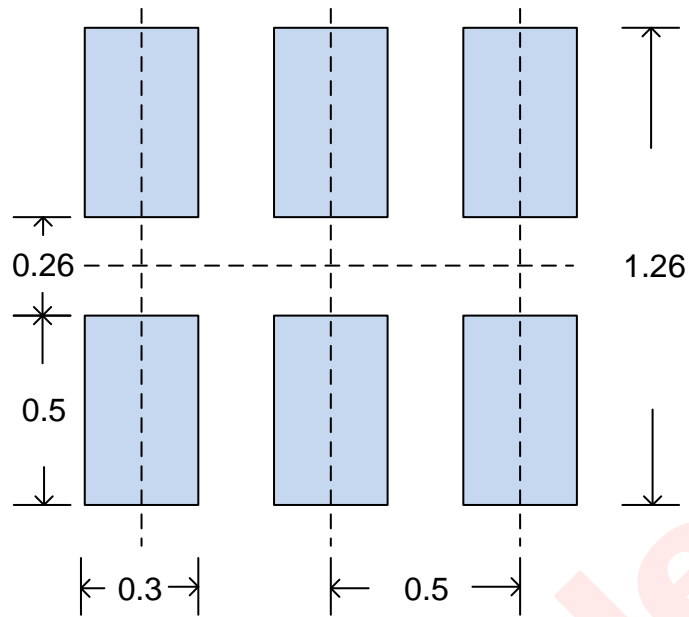

NOTE: Dimensions are in millimeters.

REFLOW

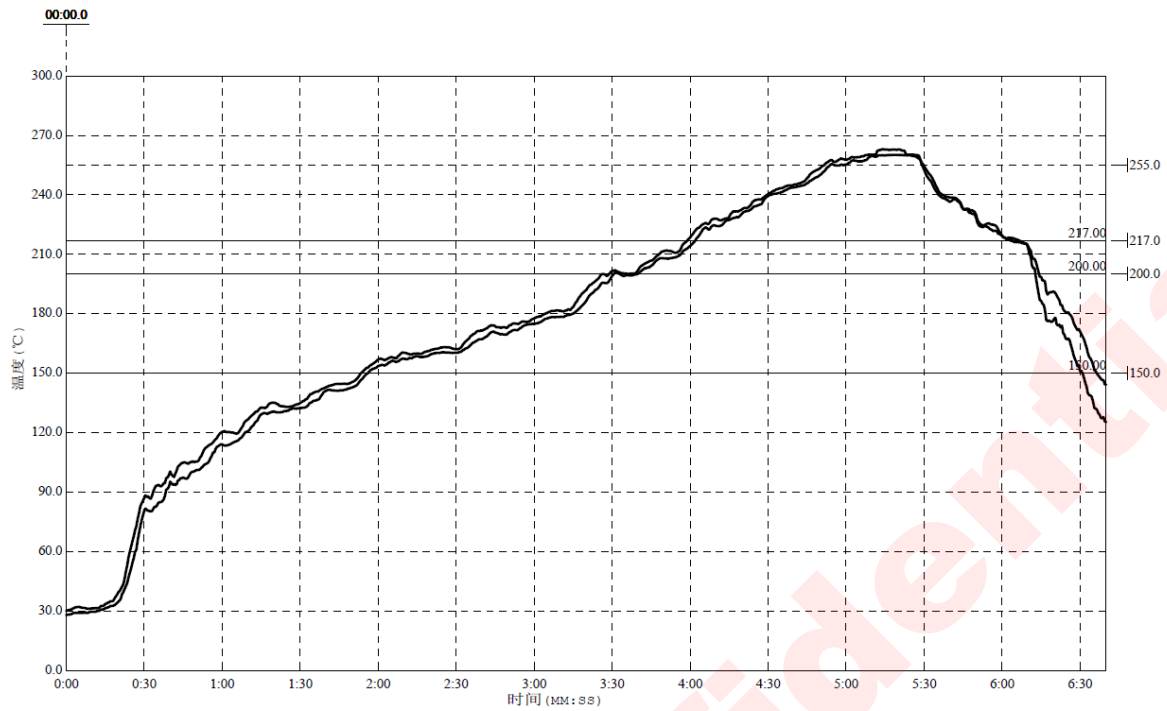

Reflow Note	Spec
Average ramp-up rate (217°C to Peak)	Max. 3°C /sec
Time of Preheat temp.(from 150°C to 200°C)	60-120sec
Time to be maintained above 217°C	60-150sec
Peak Temperature	>260°C
Time within 5°C of actual peak temp	20-40sec.
Ramp-down rate	Max. 6°C /sec
Time from 25°C to peak temp	Max. 8min.

Version information

VERSION	DATE	Change Record
V1.0	2017.10	Datasheet V1.0 Released.
V1.1	2018.1	1. Add User Direction of Feed. (P11) 2. Modify Spec of T _{ON_DELAY} .(P6) 3. Modify Description of Test Conditions of T _{SHDN} . (P6)
V1.2	2018.4	1. Add Spec of Torch Current.(P6) 2. Rotate Pin Configuration(Figure 2) by 90 degrees.(P2) 3. Add upper limit of V _{DROP} . (P6)
V1.3	2018.5	1.Modify "Max Junction Temperature T _{JMAX} " from125°C to 155°C.(P5)

DISCLAIMER

Information in this document is believed to be accurate and reliable. However, Shanghai AWINIC Technology Co., Ltd (AWINIC Technology) does not give any representations or warranties, expressed or implied, as to the accuracy or completeness of such information and shall have no liability for the consequences of use of such information.

AWINIC Technology reserves the right to make changes to information published in this document, including without limitation specifications and product descriptions, at any time and without notice. Customers shall obtain the latest relevant information before placing orders and shall verify that such information is current and complete. This document supersedes and replaces all information supplied prior to the publication hereof.

AWINIC Technology products are not designed, authorized or warranted to be suitable for use in medical, military, aircraft, space or life support equipment, nor in applications where failure or malfunction of an AWINIC Technology product can reasonably be expected to result in personal injury, death or severe property or environmental damage. AWINIC Technology accepts no liability for inclusion and/or use of AWINIC Technology products in such equipment or applications and therefore such inclusion and/or use is at the customer's own risk.

Applications that are described herein for any of these products are for illustrative purposes only. AWINIC Technology makes no representation or warranty that such applications will be suitable for the specified use without further testing or modification.

All products are sold subject to the general terms and conditions of commercial sale supplied at the time of order acknowledgement.

Nothing in this document may be interpreted or construed as an offer to sell products that is open for acceptance or the grant, conveyance or implication of any license under any copyrights, patents or other industrial or intellectual property rights.

Reproduction of AWINIC information in AWINIC data books or data sheets is permissible only if reproduction is without alteration and is accompanied by all associated warranties, conditions, limitations, and notices. AWINIC is not responsible or liable for such altered documentation. Information of third parties may be subject to additional restrictions.

Resale of AWINIC components or services with statements different from or beyond the parameters stated by AWINIC for that component or service voids all express and any implied warranties for the associated AWINIC component or service and is an unfair and deceptive business practice. AWINIC is not responsible or liable for any such statements.