

## 1A Lithium Titanate Battery Charger IC CN3155

### General Description:

The CN3155 is a complete constant-current /constant voltage linear charger for single cell or dual-cell lithium titanate rechargeable batteries. The device contains an on-chip power MOSFET and eliminates the need for the external current sense resistor and blocking diode. Its low external component count makes CN3155 ideally suited for portable applications.

Thermal feedback regulates the charge current to limit the die temperature during high power operation or high ambient temperature. The regulation voltage is internally fixed at 2.75V or 5.5V depending on CELL pin voltage level, it can also be adjusted upwards with an external resistor. The charge current can be programmed externally with a single resistor. When the input supply is removed, the CN3155 automatically enters a low power sleep mode, dropping the battery drain current to less than 3uA. Other features include under-voltage lockout, automatic recharge and charging/termination indicator.

The CN3155 is available in thermally enhanced 8-pin SOP/PP package.

### Applications:

- Electronic Toys
- Power Bank
- Portable Devices
- Variety Of Chargers

### Features:

- Charge Management for 1 or 2-cell Lithium Titanate Batteries
- On-chip Power MOSFET
- No external Blocking Diode or Current Sense Resistors Required
- Constant Charge Voltage 2.75V or 5.5V, can be adjusted upwards by an external resistor
- Precharge Conditioning for Reviving Deeply Discharged Cells and Minimizing Heat Dissipation During Initial Stage of Charge
- Can be used as a Voltage Source
- Programmable Continuous Charge Current Up to 1A
- Constant-Current/Constant-Voltage/Constant-Temperature Operation to Maximize Charge Rate Without Risk of Overheating
- Automatic Low-Power Sleep Mode When Input Supply is Removed
- Status Indication for LEDs or uP Interface
- C/10 Charge Termination
- Automatic Recharge
- Pb-free, rohs compliant, halogen free

### Pin Assignment

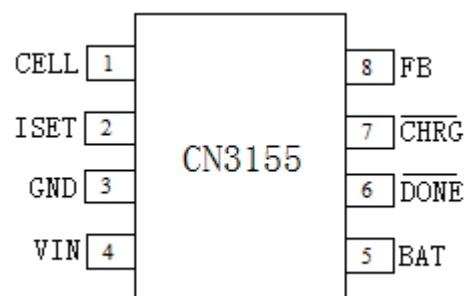

# CONSONANCE

## Typical Application Circuit

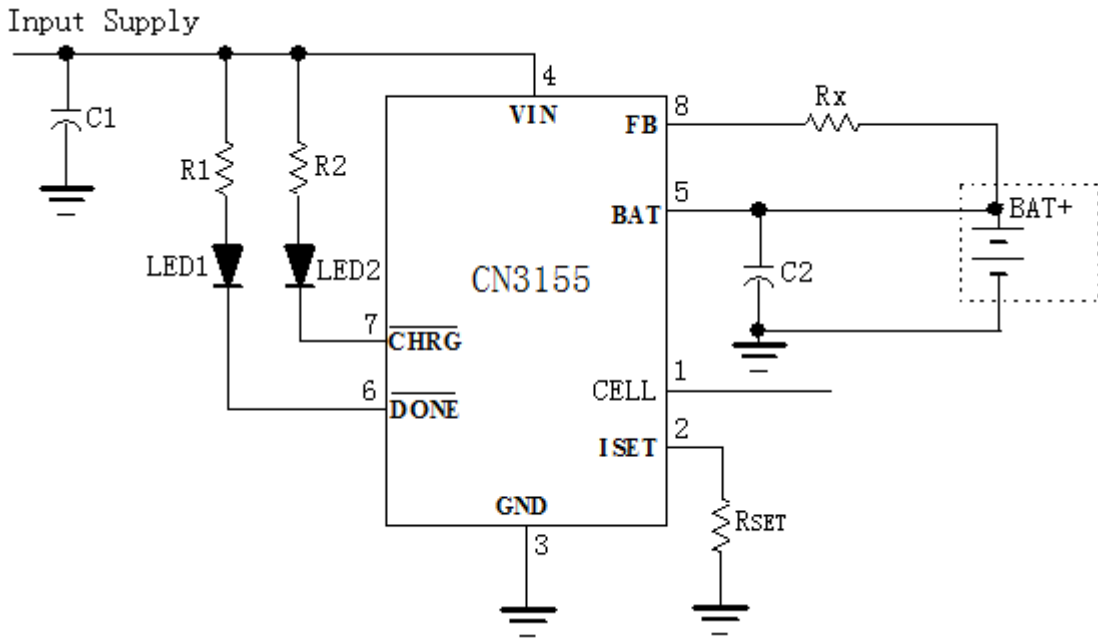

Figure 1 Typical Application Circuit

In Figure 2, the BAT pin's voltage in constant voltage mode is given by the following equation:

$$V_{bat} = 2.75 + 3.61 \times 10^{-6} \times R_x \quad \text{if CELL pin is low, or}$$

$$V_{bat} = 5.5 + 3.61 \times 10^{-6} \times R_x \quad \text{if CELL pin is high}$$

Where,  $V_{bat}$  is in volt

$R_x$  is in ohm

Note: when an external resistor is used to adjust constant charge voltage, the voltage accuracy may be affected due to the process variation and the difference in temperature coefficient between the silicon and the environment.

## Ordering Information:

Part No.	Package	Shipping	Operating Temperature Range
CN3155	SOP8/PP	Tape and Reel, 4000/Reel	-40°C to +85°C

# CONSONANCE

## Block Diagram

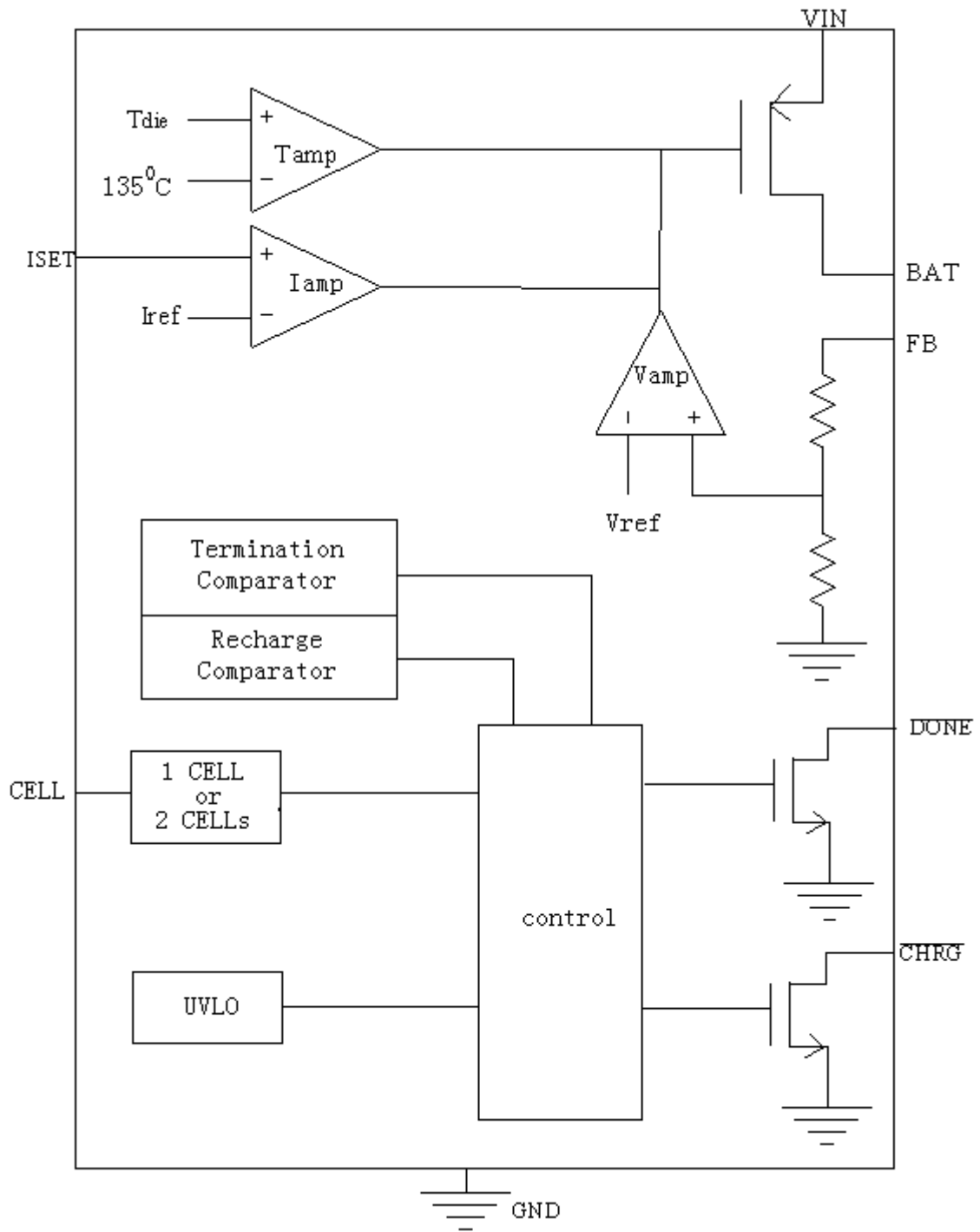

Figure 2 Block Diagram

# CONSONANCE

## Pin Description

Pin No.	Name	Function Description
1	CELL	<b>Cell number setting Pin.</b> If CELL pin is logic-low, 1-cell lithium titanate battery is charged, and the constant voltage is regulated at 2.75V(FB short to BAT); If CELL pin is logic-high, 2-cell lithium titanate batteries are charged, and the constant voltage is regulated at 5.5V(FB short to BAT).
2	ISET	<b>Constant Charge Current Setting and Charge Current Monitoring Pin.</b> The charge current is set by connecting a resistor R <sub>ISET</sub> from this pin to GND. When in trickle charge mode, the ISET pin's voltage is regulated to 0.12V. When in constant charge current mode, the ISET pin's voltage is regulated to 1.205V. In all modes during charging, the voltage on ISET pin can be used to measure the charge current as follows: $I_{CH} = (V_{ISET} / R_{ISET}) \times 1011$
3	GND	<b>Ground Terminal.</b>
4	VIN	<b>Positive Terminal of Input Supply Voltage.</b> VIN is the power supply to the internal circuit. When VIN drops to within 10mv of the BAT pin voltage, CN3155 enters low power sleep mode, dropping BAT pin's current to less than 3uA.
5	BAT	<b>Battery Connection Pin.</b> Connect the positive terminal of the battery to BAT pin. BAT pin draws less than 3uA current in sleep mode. BAT pin provides charge current to the battery.
6	$\overline{DONE}$	<b>Charge termination Status Output.</b> Open drain output. In charge termination status, $\overline{DONE}$ is pulled low by an internal switch; Otherwise $\overline{DONE}$ pin is in high impedance state.
7	$\overline{CHRG}$	<b>Charge Status Output.</b> When the battery is being charged, the $\overline{CHRG}$ pin is pulled low by an internal switch, otherwise $\overline{CHRG}$ pin is in high impedance state.
8	FB	<b>Battery Voltage Kelvin Sense Input.</b> This Pin can Kelvin sense the battery voltage; Also the regulation voltage in constant voltage mode can be adjusted upwards by connecting an external resistor between FB and BAT pin.
9	EP	<b>Exposed PAD.</b> Should be connected to GND.

## Absolute Maximum Ratings

All Terminal Voltage..... -0.3V to 6.5V  
 BAT Short-Circuit Duration..... Continuous  
 Storage Temperature..... -65°C to 150°C  
 Thermal Resistance ..... TBD

Maximum Junction Temperature..... 150°C  
 Operating Temperature..... -40°C to 85°C  
 Lead Temperature(Soldering)..... 260°C

*Stresses beyond those listed under 'Absolute Maximum Ratings' may cause permanent damage to the device. These are stress ratings only and functional operation of the device at these or any other conditions above those indicated in the operational sections of the specifications is not implied. Exposure to Absolute Maximum Rating Conditions for extended periods may affect device reliability.*

# CONSONANCE

## Electrical Characteristics

(VIN=5V, TA=−40°C to 85°C, Typical Values are measured at TA=25°C, unless otherwise noted)

Parameters	Symbol	Test Conditions	Min	Typ	Max	Unit	
Input Supply Voltage	VIN		3.0		6.0	V	
Operating Current	IVIN	Charge Termination Mode	300	450	600	uA	
Undervoltage Lockout	Vuvlo	VIN falling		2.0	3.0	V	
Regulation Voltage	VREG	CELL pin is logic-low	2.72	2.75	2.78	V	
		CELL pin is logic-high	5.445	5.5	5.555		
BAT pin Current	IBAT	RISET=1.22K, constant current mode	850	1000	1150	mA	
		RISET=1.22K, precharge mode	75	100	125		
		VIN=0V, sleep mode			3	uA	
<b>Precharge Threshold</b>							
Precharge Threshold	VPRE	FB voltage rises, FB short to BAT	CELL=0	1.55	1.65	1.75	V
			CELL=1	3.16	3.3	3.44	
Precharge Threshold Hysteresis	HPRE	FB voltage falls, FB short to BAT	CELL=0		0.16	V	
			CELL=1		0.32		
<b>Charge Termination Threshold</b>							
Charge Termination Threshold	Vterm	VISET falls, measure voltage at ISET pin	0.096	0.12	0.144	V	
<b>Recharge Threshold</b>							
Recharge Threshold	VRECH	VISET rises, measure voltage at ISET pin	0.535	0.6	0.665	V	
<b>Sleep Mode</b>							
Sleep Mode Threshold	VSLP	VIN from high to low, measures the voltage (VIN−VBAT)		10		mv	
Sleep mode Release Threshold	VSLPR	VIN from low to high, measures the voltage (VIN−VBAT)		60		mv	
<b>ISET Pin</b>							
ISET Pin Voltage	VISET	Precharge mode	0.09	0.12	0.15	V	
		Constant current mode	1.11	1.205	1.30		
<b>FB Pin</b>							
FB Input Current 1	IFB1	VFB=2.5V, normal operation	4.1	6.3	8.5	uA	
FB Input Current 1	IFB2	VIN<Vuvlo or VIN<VBAT			1	uA	
<b>CELL Pin</b>							
High Input Threshold	VHIGH		2.3			V	
Low Input Threshold	VLOW				0.6	V	
CELL input Current					0.5	uA	

# CONSONANCE

(Continued from last page)

Parameters	Symbol	Test Conditions	Min	Typ	Max	Unit
<b><math>\overline{\text{CHRG}}</math> Pin</b>						
$\overline{\text{CHRG}}$ Sink Current	$I_{\text{CHRG}}$	$V_{\text{CHRG}}=0.3\text{V}$ , charge mode		10		mA
$\overline{\text{CHRG}}$ Leakage Current		$V_{\text{CHRG}}=6\text{V}$ , termination mode			1	uA
<b><math>\overline{\text{DONE}}</math> Pin</b>						
$\overline{\text{DONE}}$ Sink Current	$I_{\text{DONE}}$	$V_{\text{DONE}}=0.3\text{V}$ , charge mode		10		mA
$\overline{\text{DONE}}$ Leakage Current		$V_{\text{DONE}}=6\text{V}$ , termination mode			1	uA

## Detailed Description

The CN3155 is a linear battery charger designed primarily for charging single cell or dual-cell lithium titanate batteries. Featuring an internal P-channel power MOSFET, the charger uses a constant-current/constant-voltage to charge the batteries. Continuous charge current can be programmed up to 1A with an external resistor. No blocking diode or current sense resistor is required. The open-drain output  $\overline{\text{CHRG}}$  and  $\overline{\text{DONE}}$  indicates the charger's status. The internal thermal regulation circuit reduces the programmed charge current if the die temperature attempts to rise above a preset value of approximate 135°C. This feature protects the CN3155 from excessive temperature, and allows the user to push the limits of the power handling capability of a given circuit board without risk of damaging the CN3155 or the external components. Another benefit of adopting thermal regulation is that charge current can be set according to typical, not worst-case, ambient temperatures for a given application with the assurance that the charger will automatically reduce the current in worst-case conditions. The charge cycle begins when the voltage at the VIN pin rises above the UVLO level, a current set resistor is connected from the ISET pin to ground. The  $\overline{\text{CHRG}}$  pin outputs a logic low to indicate that the charge cycle is ongoing. At the beginning of the charge cycle, if the voltage at FB pin is below the precharge threshold, the charger is in trickle charge mode, the trickle charge current is 10% of the constant charge current. The charger goes into the fast charge constant current mode once the voltage on the FB pin rises above the precharge threshold. In constant current mode, the charge current is set by  $R_{\text{ISET}}$ . When the battery approaches the regulation voltage, the charge current begins to decrease as the CN3155 enters the constant-voltage mode. When the current drops to charge termination threshold, the charge cycle is terminated,  $\overline{\text{DONE}}$  is pulled low by an internal switch and  $\overline{\text{CHRG}}$  pin assumes a high impedance state to indicate that the charge cycle is terminated. The charge termination threshold is 10% of the current in constant current mode. To restart the charge cycle, remove the input voltage and reapply it. The charge cycle can also be automatically restarted if the ISET pin voltage rises above the recharge threshold. The on-chip reference voltage, error amplifier and the resistor divider provide regulation voltage with 1% accuracy which can meet the requirement of lithium titanate batteries. When the input voltage is not present, the charger goes into a sleep mode, dropping battery drain current to less than 3uA. This greatly reduces the current drain on the battery and increases the standby time.

The charging profile is shown in figure 3:

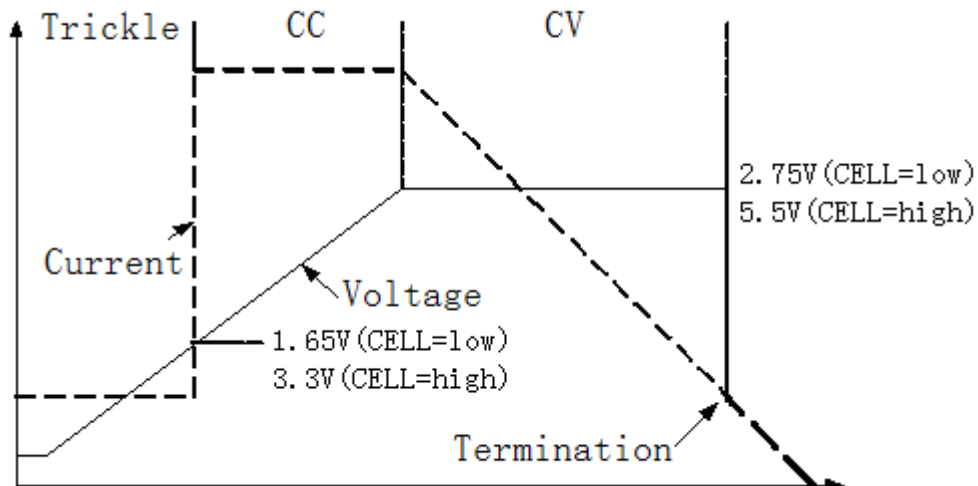

Figure 3 Charging Profile

## Application Information

### Undervoltage Lockout (UVLO)

CN3155 has an internal undervoltage lockout circuit that monitors the input voltage and keeps the charger in shutdown mode until VIN rises above the undervoltage lockout voltage.

### Sleep mode

There is an on-chip sleep comparator in CN3155. The comparator keeps the charger in sleep mode if VIN falls below sleep mode threshold (VBAT+10mv). Once in sleep mode, the charger will not come out of sleep mode until VIN rises 60mv above the battery voltage.

### Trickle charge mode

At the beginning of a charge cycle, if the battery voltage is below the precharge threshold, the charger is in trickle charge mode, the trickle charge current is 10% of the constant charge current.

### Battery Voltage Kelvin Detection

There is a battery voltage Kelvin detection input pin (FB). This pin connects with error amplifier through precise resistor divider network on chip. FB pin can be connected to battery's positive terminal directly, which can avoid the influence of parasitic resistor between positive terminal and BAT pin. The existence of these parasitic resistors would prolong the charging time, or even cause under-charge of battery. These problems can be solved by FB pin. If FB pin is floating or tied to GND, CN3155 would always in trickle charge mode.

### Setting Charge Current

The formula for the battery charge current in constant current mode is:

$$I_{CH} = 1218V / R_{ISET}$$

Where:  $I_{CH}$  is the charge current in ampere

$R_{ISET}$  is the total resistance from the ISET pin to ground in ohm

For best stability over temperature and time, 1% metal film resistors are recommended. If the charger is in constant-current or constant voltage mode, the charge current can be monitored by measuring the ISET pin voltage, and the charge current is calculated as the following equation:

$$I_{CH} = (V_{ISET} / R_{ISET}) \times 1011$$

### Adjusting the regulation voltage in constant voltage mode

The regulation voltage in constant voltage mode can be adjusted by an external resistor connecting between FB pin and BAT pin as shown in Figure 4:

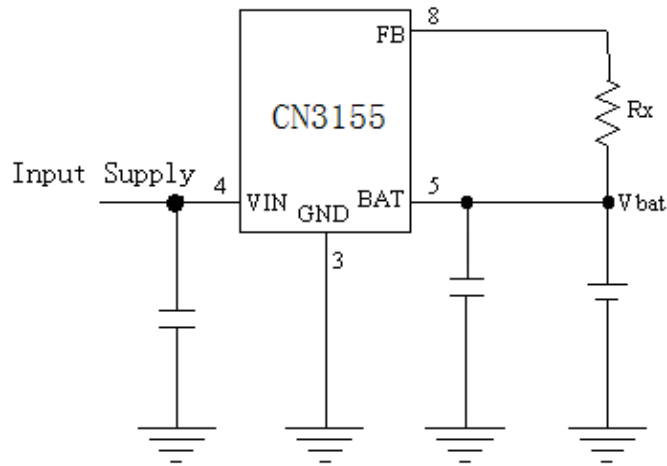

**Figure 4 Adjust Regulation Voltage in Constant Voltage Mode**

In Figure 4, the regulation voltage in constant voltage mode will be given by the following equation:

$$\begin{aligned} V_{bat} &= 2.75 + 3.61 \times 10^{-6} \times R_x && \text{If CELL is logic-low, or} \\ V_{bat} &= 5.5 + 3.61 \times 10^{-6} \times R_x && \text{If CELL is logic-high} \end{aligned}$$

Where,  $V_{bat}$  is in volt,  
 $R_x$  is in ohm

### About Typical Application Circuit

The detailed description on the components in typical application circuit of Figure 1:

No.	Symbol	Description
1	R1	Resistors for LED current limit.
2	R2	
3	$R_{ISET}$	The resistor to set constant charge current, the charge current is determined by: $I_{CH} = 1218V / R_{ISET}$
4	$R_x$	The resistor to adjust the constant charge voltage. The regulation voltage in constant charge voltage mode is: $V_{bat} = 2.75 + 3.61 \times 10^{-6} \times R_x \quad \text{If CELL is logic-low, or}$ $V_{bat} = 5.5 + 3.61 \times 10^{-6} \times R_x \quad \text{If CELL is logic-high}$
5	C1	Many types of capacitors can be used for the bypassing capacitor, Generally, a 1uF ceramic capacitor, placed in close proximity to VIN and GND pins, works well. In some applications depending on the power supply characteristics and cable length, it may be necessary to increase the capacitor's value. For the consideration of the bypass capacitor, please refer to the Application Note AN102 from our website.
6	C2	Output capacitor, 4.7uF to 10uF.
7	LED1	LED indicator for charge termination.
8	LED2	LED indicator for charge status.

### Charge Termination

In constant voltage mode, when the charging current decreases to 10% of the constant current, CN3155 will enter into termination mode.

### Recharge

In charge termination mode, if the charge current rises above 50% of constant current, CN3155 will enter into charge mode again.

# CONSONANCE

## Constant-Current/Constant-Voltage/Constant-Temperature

The CN3155 use a unique architecture to charge a battery in a constant-current, constant-voltage, constant temperature fashion as shown in Figure 2. Amplifiers Iamp, Vamp, and Tamp are used in three separate feedback loops to force the charger into constant-current, constant-voltage, or constant-temperature mode, respectively. In constant current mode the charge current delivered to the battery equal to  $1218V/R_{ISET}$ . If the power dissipation of the CN3155 results in the junction temperature approaching 135°C, the amplifier Tamp will begin decreasing the charge current to limit the die temperature to approximately 135°C. As the battery voltage rises, the CN3155 either returns to constant-current mode or it enters constant voltage mode straight from constant-temperature mode.

## Open-Drain Status Outputs

The CN3155 have 2 open-drain status outputs:  $\overline{CHRG}$  and  $\overline{DONE}$ .  $\overline{CHRG}$  is pulled low when the charger is in charging mode, otherwise  $\overline{CHRG}$  becomes high impedance.  $\overline{DONE}$  is pulled low if the charger is in charge termination mode, otherwise  $\overline{DONE}$  becomes high impedance.

The following table lists the two indicator status and its corresponding charging state. It is supposed that red LED is connected to  $\overline{CHRG}$  pin and green LED is connected to  $\overline{DONE}$  pin.

$\overline{CHRG}$ pin	$\overline{DONE}$ pin	State Description
Low(red LED on)	High Impedance(green LED off)	Charging
High Impedance(red LED off)	Low(green LED on)	Charge termination
High Impedance(red LED off)	High Impedance(green LED off)	There are three possible state: <ul style="list-style-type: none"> <li>● the voltage at the VIN pin below the UVLO level or</li> <li>● the voltage at the VIN pin below <math>V_{BAT}</math> or</li> </ul>

Grounding  $\overline{CHRG}$  or  $\overline{DONE}$  pins if not used.

## Stability

Typically a 4.7uF to 10uF capacitor(C2 in Figure 1) from BAT pin to GND is required to stabilize the feedback loop.

In constant current mode, the stability is also affected by the impedance at the ISET pin . With no additional capacitance on the ISET pin, the loop is stable with current set resistors values as high as 50K  $\Omega$  . However, additional capacitance on ISET pin reduces the maximum allowed current set resistor. The pole frequency at ISET pin should be kept above 200KHz. Therefore, if ISET pin is loaded with a capacitance C, the following equation should be used to calculate the maximum resistance value for  $R_{ISET}$ :

$$R_{ISET} < 1 / (6.28 \times 2 \times 10^5 \times C)$$

## VIN Bypass Capacitor

In most applications, a high-frequency bypass capacitor(C1 in Figure 1) is needed for input supply. Generally, a 1uF ceramic capacitor, placed in close proximity to VIN and GND pins, works well. In some applications depending on the power supply characteristics and cable length, it may be necessary to increase the capacitor's value.

If the ceramic capacitor is used as the input supply bypassing purpose, a voltage spike may be created when the input voltage is applied to the CN3155 via a cable. If the cable is a bit long, the circuit shown in Figure 5 or a TVS diode from VIN pin to GND should be considered to use to prevent the CN3155 from being damaged by the voltage spike.

For the consideration of the bypass capacitor, please refer to the Application Note AN102 from our website.

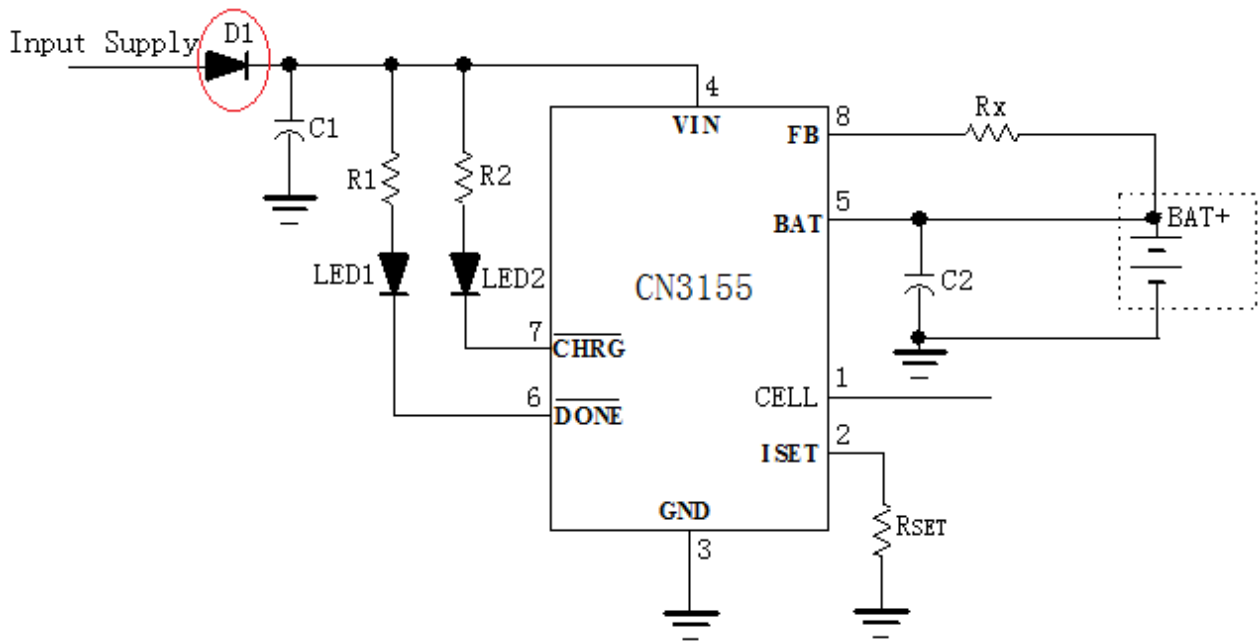

Figure 5 Adding Diode D1 to Suppress Voltage Spike

## Board Layout Considerations

1.  $R_{ISET}$  at ISET pin should be as close to CN3155 as possible, also the parasitic capacitance at ISET pin should be kept as small as possible.
2. The capacitance at VIN pin and BAT pin should be as close to CN3155 as possible.
3. During charging, CN3155's temperature may be high, the NTC thermistor should be placed far enough to CN3155 so that the thermistor can reflect the battery's temperature correctly.
4. It is very important to use a good thermal PC board layout to maximize charging current. The thermal path for the heat generated by the IC is from the die to the copper lead frame through the package lead (especially the ground lead) to the PC board copper, the PC board copper is the heat sink. The footprint copper pads should be as wide as possible and expand out to larger copper areas to spread and dissipate the heat to the surrounding ambient. Feedthrough vias to inner or backside copper layers are also useful in improving the overall thermal performance of the charger. Other heat sources on the board, not related to the charger, must also be considered when designing a PC board layout because they will affect overall temperature rise and the maximum charge current. The ability to deliver maximum charge current under all conditions require that the exposed metal pad on the back side of the CN3155 package be soldered to the PC board ground. Failure to make the thermal contact between the exposed pad on the backside of the package and the copper board will result in larger thermal resistance.

# CONSONANCE

## Package Information

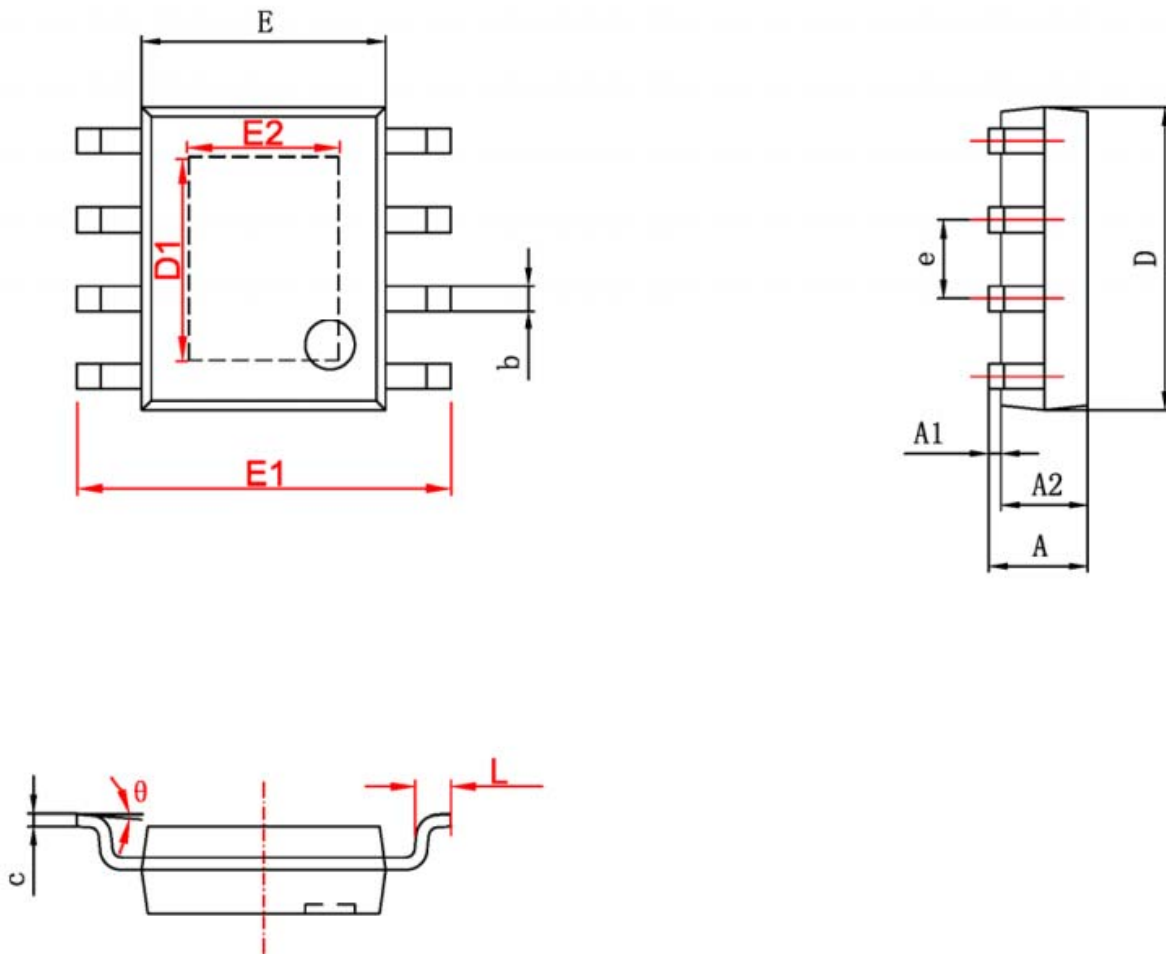

字符	Dimensions In Millimeters		Dimensions In Inches	
	Min	Max	Min	Max
A	1.350	1.750	0.053	0.069
A1	0.050	0.150	0.004	0.010
A2	1.350	1.550	0.053	0.061
b	0.330	0.510	0.013	0.020
c	0.170	0.250	0.006	0.010
D	4.700	5.100	0.185	0.200
D1	3.202	3.402	0.126	0.134
E	3.800	4.000	0.150	0.157
E1	5.800	6.200	0.228	0.244
E2	2.313	2.513	0.091	0.099
e	1.270 (BSC)		0.050 (BSC)	
L	0.400	1.270	0.016	0.050
θ	0°	8°	0°	8°

Consonance does not assume any responsibility for use of any circuitry described. Consonance reserves the right to change the circuitry and specifications without notice at any time.

1000 万+元器件 PDF 数据手册在线免费下载: <https://pdf.ttic.cc>

Electronic Component Datasheets Free Download: <https://pdf.ttic.cc>

国内知名度极高的电子元器件行业 B2B 供求平台（1 亿+库存信息，30 万+日访问量，终端工程师及工厂首选平台）: <https://www.ttic.cc>

Highly renowned B2B supply and demand platform for electronic components industry (More than 100,000,000 inventory information, More than 300,000 visits per daily , preferred platform for terminal engineers and factories):  
<https://www.ttic.cc>

全球供应商库存及价格信息: <http://price.hqbdsj.com>

Electronic Component's Price & Stock: <http://price.hqbdsj.com>