

Date Sheet



華 芯

WWW.WXHXKJ.COM

The "Huaxin" brand was founded in 2003 and has a history of 18 years. The company is mainly engaged in Hall elements, has a group of senior professional device design, integrated circuit design and test engineers, and has a first-class development and test platform. We have developed a number of high-end products with independent intellectual property rights, such as RF LDMOS series and RF VDMOS series, which represent China's integrated circuit level.

HX6472

Omnipolar Hall Switch

HX6472 Hall effect switch is a temperature stable, Superior high-temperature performance is made possible through a dynamic offset cancellation that utilizes chopper-stabilization.

HX6472 includes the following on a single silicon chip: voltage regulator, Hall voltage generator, small-signal amplifier, chopper stabilization, Schmitt trigger, and open drain output. Advanced DMOS wafer fabrication processing is used to take advantage of low-voltage requirements, component matching, very low input-offset errors, and small component geometries.

This device requires the presence of omni-polar magnetic fields for operation.

HX6472 is rated for operation between the ambient temperatures -40°C and $+85^{\circ}\text{C}$ for the E temperature range. and -40°C to 125°C for the K temperature range. The two package styles available provide magnetically optimized solutions for most applications. Package types SO is an SOT-23, a miniature low-profile surface-mount package, while package UA is a three-lead ultra-mini SIP for through-hole mounting.

The package type is in a Halogen Free version was verified by third party Lab.

Features and Benefits

- DMOS Hall IC Technology.
- Operation range from 2.5V to 30V .
- Omni polar, output switches with absolute value of North or South pole from magnet.
- Reverse bias protection on power supply pin.
- High Sensitivity for reed switch replacement applications.
- Low sensitivity drift in crossing of Temp range.
- High ESD Protection, HBM $> \pm 4\text{KV}(\text{min})$

Applications

- Solid state switch.
- Limit switch.
- Magnet proximity sensor
- Position sensor
- Speed sensor
- Rotation sensor
- Counting sensor

Ordering Information

	<p>Company Name and Product Category HX:HX Hall Effect/MP:HX Power MOSFET</p> <p>Part number 6286,6275,6278,6287,6383,6474,6571,6572,6573,6574...</p> <p>If part # is just 3 digits, the forth digit will be omitted.</p> <p>Temperature range E: 85 °C, I: 105 °C, K: 125 °C, L: 150 °C</p> <p>Package type UA:TO-92S,VK:TO-92S(4pin),VF:TO-92S(5pin),SO:SOT-23, SQ:QFN-3,ST:TSOT-23,SN:SOT-553,SF:SOT-89(5pin)</p> <p>Sorting α, β, Blank.....</p>
---	--

Part No.	Temperature Suffix	Package Type
HX6472KUA	K (-40°C to + 125°C)	UA (TO-92S)
HX6472EUA	E (-40°C to + 85°C)	UA (TO-92S)
HX6472KSO	K (-40°C to + 125°C)	SO (SOT-23)
HX6472ESO	E (-40°C to + 85°C)	SO (SOT-23)

KUA spec is using in industrial and automotive application. Special Hot Testing is utilized.

Functional Diagram

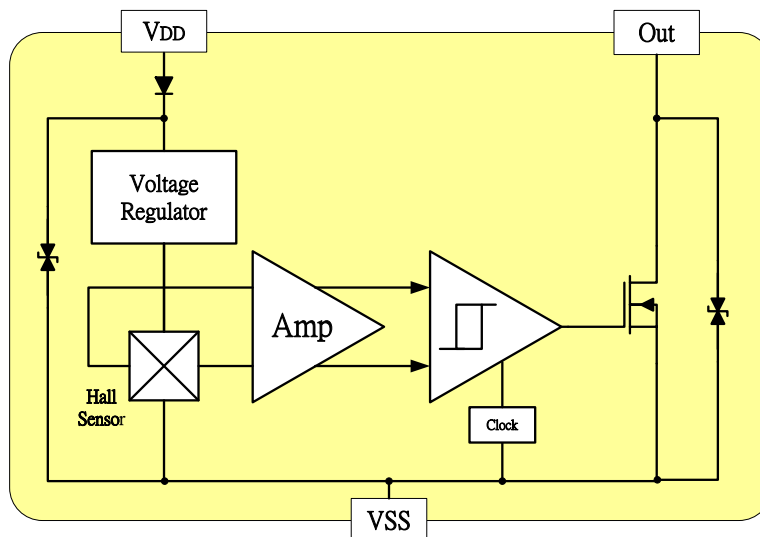

Absolute Maximum Ratings At ($T_a=25^{\circ}\text{C}$)

Characteristics		Values	Unit
Supply voltage, (V_{DD})		36	V
Output Voltage, (V_{out})		36	V
Reverse Voltage, (V_{DD} / V_{out})		-36/-0.3	V
Output current, (I_{SINK})		25	mA
Operating Temperature Range, (T_A)	“E” Class	-40 ~ +85	$^{\circ}\text{C}$
	“K” Class	-40 ~ +125	$^{\circ}\text{C}$
Storage temperature Range, (T_s)		-55 ~ +150	$^{\circ}\text{C}$
Maximum Junction Temp, (T_j)		150	$^{\circ}\text{C}$
Thermal Resistance	(θ_{JA}) UA/ SO	206 / 543	$^{\circ}\text{C}/\text{w}$
	(θ_{JC}) UA/ SO	148 / 410	$^{\circ}\text{C}/\text{w}$
Package Power Dissipation, (P_D)		606 / 230	mW

Note: Do not apply reverse voltage to V_{DD} and V_{OUT} Pin, It may be caused for Miss function or damaged device.

Electrical Specifications

DC Operating Parameters : $T_A=+25^{\circ}\text{C}$, $V_{DD}=12\text{V}$

Parameters	Test Conditions	Min	Typ	Max	Units
Supply Voltage, (V_{DD})	Operating	2.5		30.0	V
Supply Current, (I_{DD})	$B < B_{OP}$		1.7	2.5	mA
Output Saturation Voltage, (V_{DSON})	$I_{out}=20\text{mA}, B > B_{OP}$		300	500.0	mV
Output Leakage Current, (I_{off})	$I_{OFF} B < B_{RP}, V_{OUT} = 20\text{V}$			10.0	μA
Power-On Time, (T_P)				50	μs
Output Switch Time, (T_{SW})				150	μs
Output Switch Frequency, (F_{SW})		3			kHz
Output Rise Time, (T_R)	$R_L=1\text{K}\Omega, C_L=20\text{pF}$		0.04	0.45	μs
Output Fall Time, (T_F)	$R_L=1\text{k}\Omega; C_L=20\text{pF}$		0.18	0.45	μs
Electro-Static Discharge	HBM	4			KV
Operate Point, $BOPS(B_{OPN})$	$B > B_{OPS}(B < B_{OPN}), V_{OUT}$ On	± 10	± 20	± 30	Gauss
Release Point, $BRPS(B_{RPN})$	$B < B_{RPS}(B > B_{RPN}), V_{OUT}$ Off	± 5	± 10	± 15	Gauss
Hysteresis, (B_{HYS})	$ B_{OP} - B_{RP} $		10		Gauss

Typical application circuit

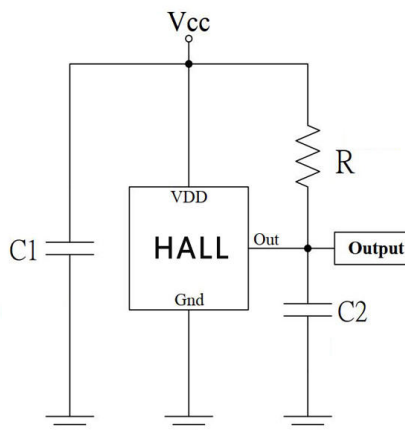

$C1 : 100\text{nF}$
 $C2 : 1\text{nF}$
 $R1 : 1\text{K}\Omega$

Sensor Location, Package Dimension and Marking

UA Package

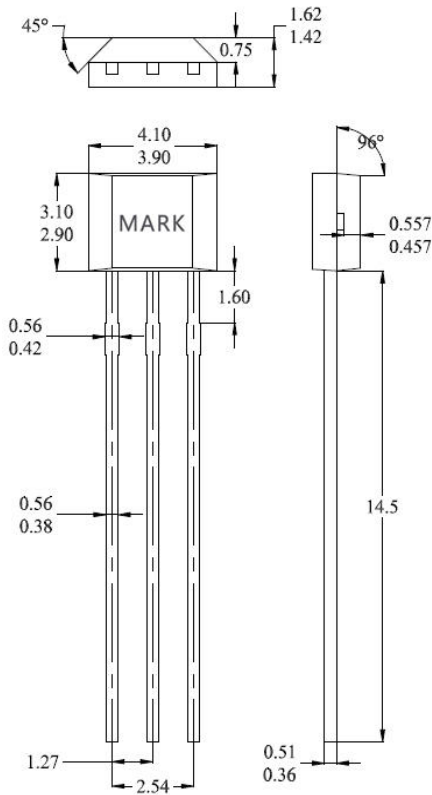

Hall Chip Location

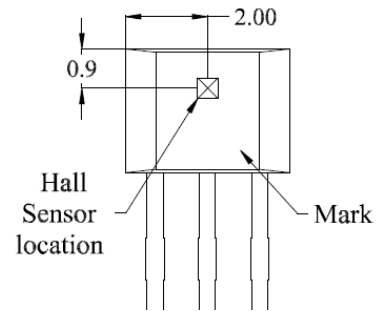

Output Pin Assignment (Top View)

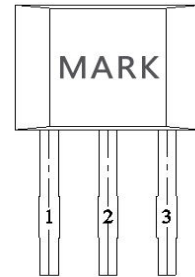

NOTES:

- 1).Controlling dimension: mm
- 2).Leads must be free of flash and plating voids
- 3).Do not bend leads within 1 mm of lead to package interface.
- 4).PINOUT:

Pin 1	V _{DD}
Pin 2	GND
Pin 3	Output

Package (SOT-23) (Top View)

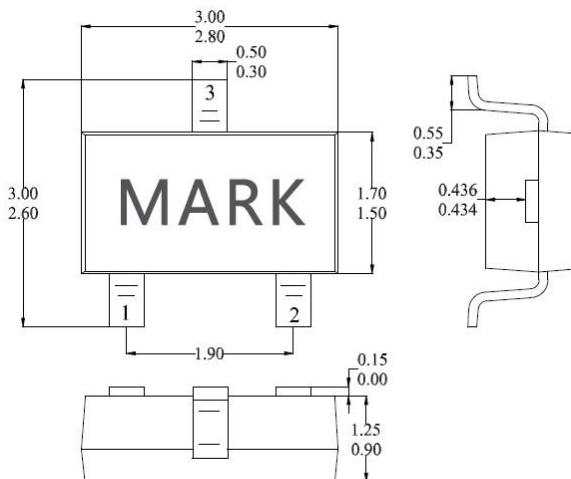

Hall Plate Chip Location (Bottom View)

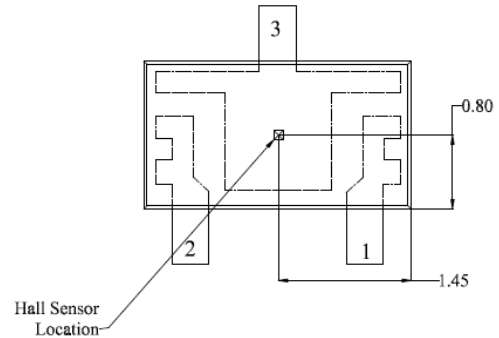

(For reference only) Land Pattern

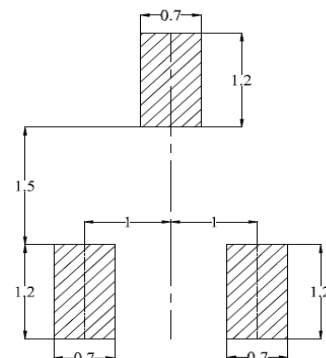

NOTES:

1. PINOUT (See Top View at left :)
Pin 1 V_{DD}; Pin 2 Output; Pin 3 GND
2. Controlling dimension: mm
3. Lead thickness after solder plating will be 0.254mm maximum

Warm reminder

1. Hall is a sensitive device. Please take electrostatic protection measures during use and storage.

2. During the installation process, the Hall should try to avoid applying mechanical stress to the Hall body. If the pins need to be bent, please operate at a distance of 3 mm from the root of the lead.

3. Recommended soldering temperature: soldering with electric soldering iron, the recommended temperature is 350°C, the longest is 5 seconds.

Wave soldering: The recommended maximum temperature is 260°C, the longest is 3 seconds

Infrared reflow soldering: recommended maximum 245°C, maximum 10 seconds

4. It is not recommended to exceed the parameters in the data sheet. Although the Hall will work normally under the limit parameters, it may cause damage to the Hall or the actual product under extreme conditions for a long time. In order to ensure the normal operation of the Hall and the product For safety and stability, please use it within the scope of the data sheet.

For the latest version of this document, go to our website at
www.wxhjkj.com

Or for additional information contact Huaxin Direct:
Anny : 15995280078 E-mail : sales1@wxhjkj.com

Huaxin has the final right to interpret the above product data