

SE150180GTS

N-Channel Enhancement-Mode MOSFET

Revision: A

General Description

Advanced trench technology to provide excellent RDS(ON), low gate charge and low operation voltage. This device is suitable for using as a load switch or in PWM applications.

- Simple Drive Requirement
- Small Package Outline
- Surface Mount Device

Features

For a single MOSFET

- $V_{DS} = 150V$
- $R_{DS(ON)} = 4.8m\Omega @ V_{GS}=10V$

Pin configurations

See Diagram below



TO-247S

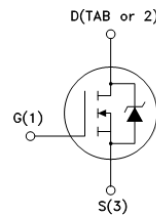

Absolute Maximum Ratings

Parameter		Symbol	Rating	Units
Drain-Source Voltage		V_{DS}	150	V
Gate-Source Voltage		V_{GS}	± 20	V
Drain Current	Continuous	I_D	164	A
	Pulsed		550	
Single pulse avalanche energy		E_{AS}	3400	mJ
Total Power Dissipation	@TA=25°C	P_D	520	W
Operating Junction Temperature Range		T_J	-55 to 175	°C

SE150180GTS

Electrical Characteristics (T _J =25°C unless otherwise noted)						
Symbol	Parameter	Test Conditions	Min	Typ	Max	Units
OFF CHARACTERISTICS (Note 2)						
BV _{DSS}	Drain-Source Breakdown Voltage	I _D =250μA, V _{GS} =0 V	150			V
I _{DSS}	Drain to Source Leakage Current	V _{DS} =150V, V _{GS} =0V			1	μA
I _{GSS}	Gate-Body Leakage Current	V _{GS} =20V			100	nA
V _{GS(th)}	Gate Threshold Voltage	V _{DS} = V _{GS} , I _D =250μA	2	3	4	V
R _{DS(ON)}	Static Drain-Source On-Resistance	V _{GS} =10V, I _D =20A	-	4.8	5.7	mΩ
g _{FS}	Forward Transconductance	V _{DS} =10V, I _D =20A		60		S
DYNAMIC PARAMETERS						
C _{iss}	Input Capacitance	V _{GS} =0V, V _{DS} =75V, f=1MHz		5977		pF
C _{oss}	Output Capacitance			476		pF
C _{rss}	Reverse Transfer Capacitance			20		pF
SWITCHING PARAMETERS						
Q _g	Total Gate Charge ²	V _{GS} =10V, V _{DS} =75V, I _D =20A		70		nC
Q _{gs}	Gate Source Charge			22		nC
Q _{gd}	Gate Drain Charge			10		nC
t _{d(on)}	Turn-On Delay Time	V _{GS} =10V, V _{DS} =75V, R _{GEN} =10Ω I _D =20A		20		ns
t _{d(off)}	Turn-Off Delay Time			37		ns
t _{d(r)}	Turn-On Rise Time			29		ns
t _{d(f)}	Turn-Off Fall Time			12		ns
Thermal Resistance						
Symbol	Parameter		Typ	Max	Units	
R _{θJC}	Thermal Resistance Junction to Case(t≤10s)		-	0.29	°C/W	

Typical Characteristics

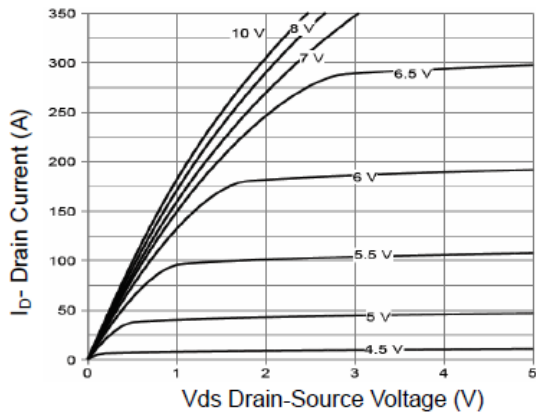

Figure 1 Output Characteristics

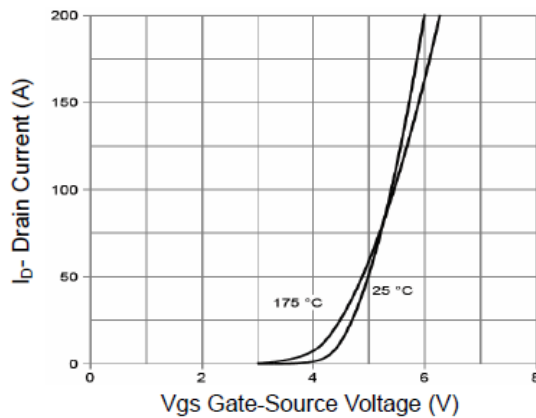

Figure 2 Transfer Characteristics

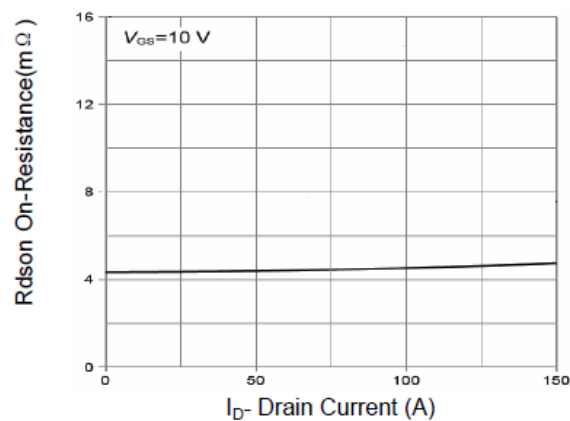

Figure 3 R_{dson} - Drain Current

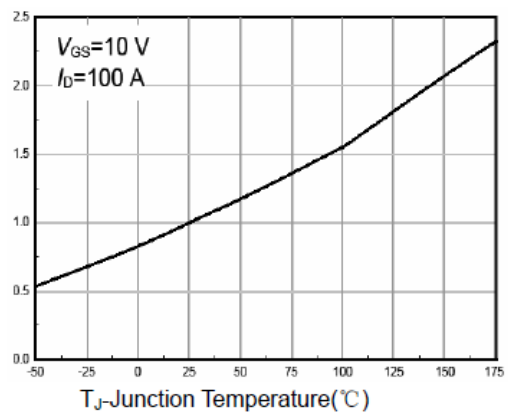

Figure 4 R_{dson} -Junction Temperature

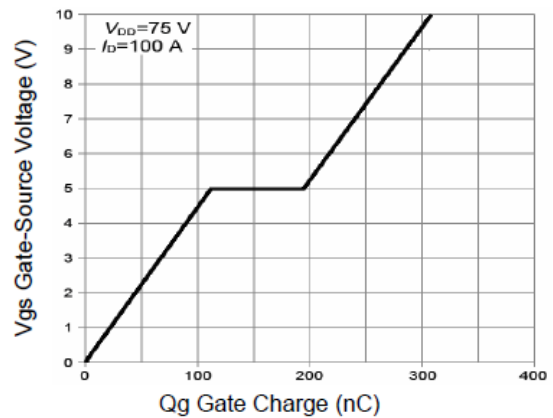

Figure 5 Gate Charge

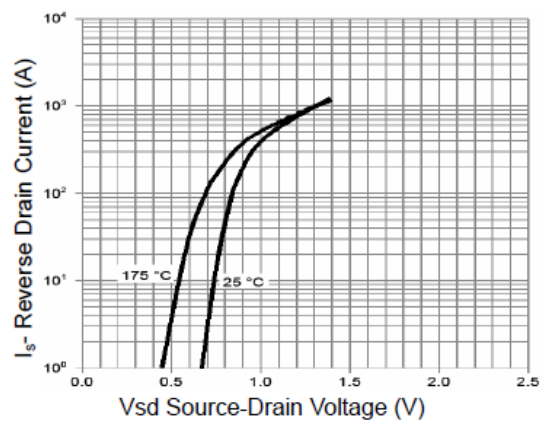

Figure 6 Source- Drain Diode Forward

Typical Characteristics

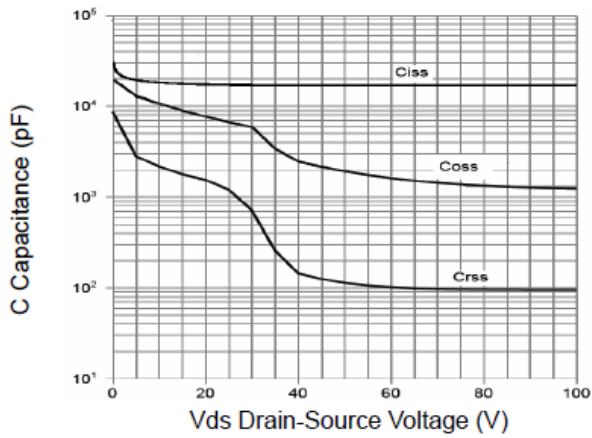

Figure 7 Capacitance vs Vds

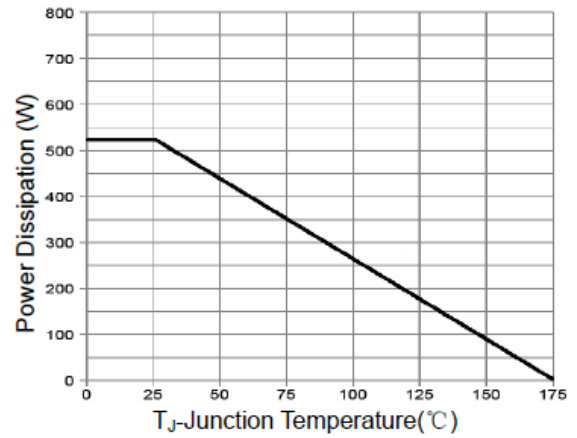

Figure 9 Power De-rating

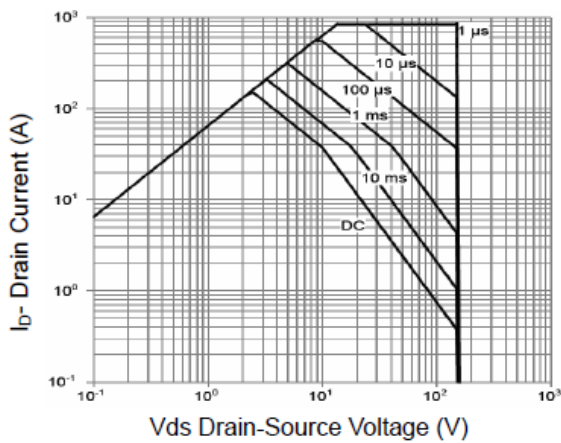

Figure 8 Safe Operation Area

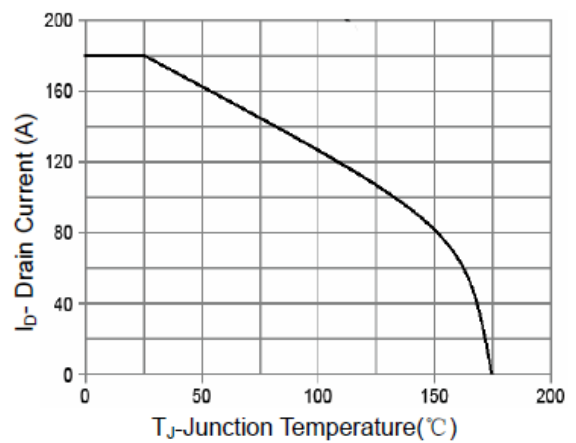

Figure 10 Current De-rating

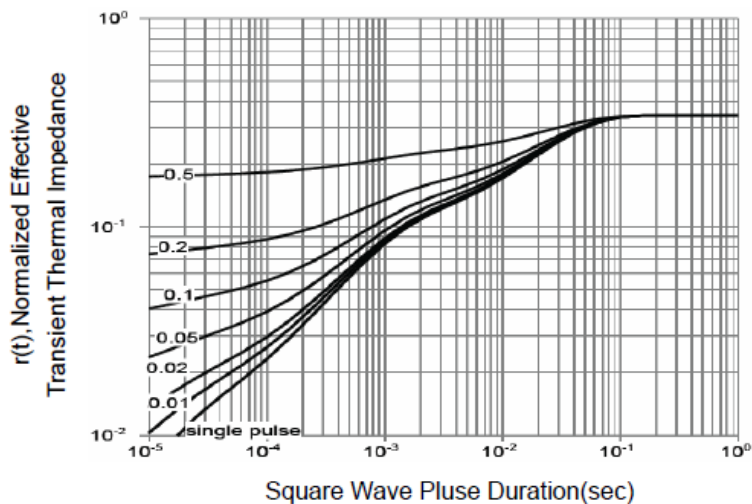
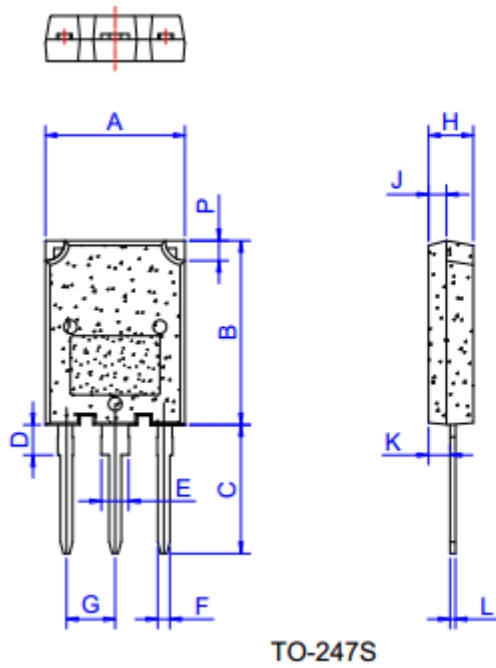

Figure 11 Normalized Maximum Transient Thermal Impedance

SE150180GTS

Package Outline Dimension

TO-247S



TO-247S

Ref.	Dimensions					
	Millimeters			Inches		
	Min.	Typ.	Max.	Min.	Typ.	Max.
A	15.1		16.1	0.594		0.634
B	19.8		20.8	0.78		0.819
C	13.8		14.8	0.543		0.583
D	3.00		4.00	0.118		0.157
E	2.75		3.35	0.108		0.132
F	1.30		1.50	0.051		0.059
G	5.10		5.80	0.201		0.228
H	4.50		5.50	0.177		0.217
J	1.45		2.15	0.057		0.085
K	1.90		2.80	0.075		0.110
L	0.55		0.80	0.022		0.031
P	2.00		2.40	0.079		0.094

The SINO-IC logo is a registered trademark of ShangHai Sino-IC Microelectronics Co., Ltd.

© 2005 SINO-IC – Printed in China – All rights reserved.

SHANGHAI SINO-IC MICROELECTRONICS CO., LTD

Add: Building 3, Room 3401-03, No.200 Zhangheng Road, ZhangJiang Hi-Tech Park, Pudong,
Shanghai 201203, China

Phone: +86-21-33932402 33932403 33932405 33933508 33933608

Fax: +86-21-33932401

Email: webmaster@sino-ic.net

Website: <http://www.sino-ic.net>