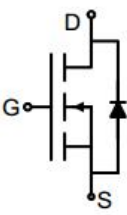



## N-Channel Enhancement Mode Power MOSFET

<p><b>Description</b></p> <p>The GT105N10T uses advanced trench technology to provide excellent <math>R_{DS(ON)}</math>, low gate charge. It can be used in a wide variety of applications.</p> <p><b>General Features</b></p> <ul style="list-style-type: none"> <li>● <math>V_{DS}</math> 100V</li> <li>● <math>I_D</math> (at <math>V_{GS} = 10V</math>) 55A</li> <li>● <math>R_{DS(ON)}</math> (at <math>V_{GS} = 10V</math>) &lt; 10.5m<math>\Omega</math></li> <li>● <math>R_{DS(ON)}</math> (at <math>V_{GS} = 4.5V</math>) &lt; 15m<math>\Omega</math></li> <li>● 100% Avalanche Tested</li> <li>● RoHS Compliant</li> </ul> <p><b>Application</b></p> <ul style="list-style-type: none"> <li>● Synchronous Rectification in SMPS or LED Driver</li> <li>● UPS</li> <li>● Motor Control</li> <li>● BMS</li> <li>● High Frequency Circuit</li> </ul>		 <p>Schematic diagram</p>  <p>TO-220</p>	
<b>Device</b>	<b>Package</b>	<b>Marking</b>	<b>Packaging</b>
GT105N10T	TO-220	GT105N10	50pcs/Tube

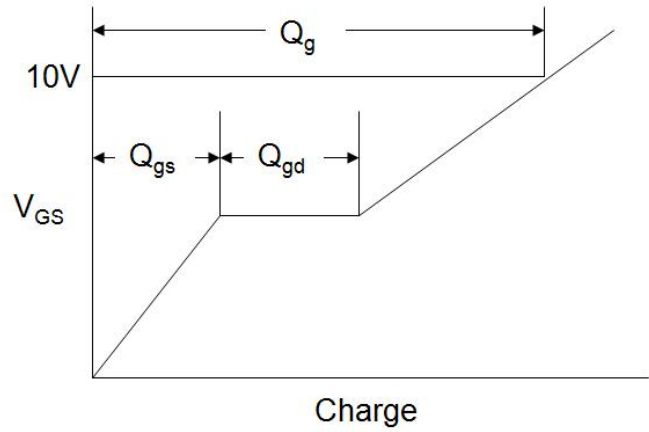
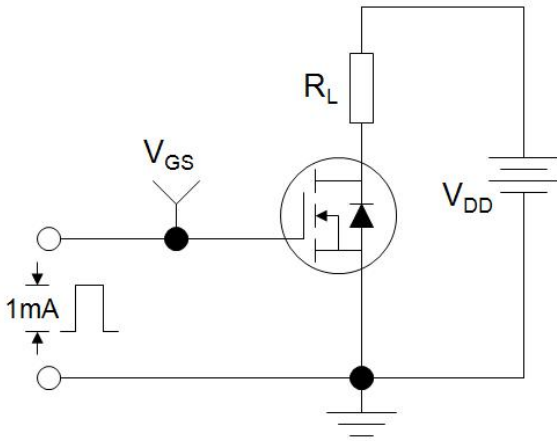
<b>Absolute Maximum Ratings</b> $T_C = 25^\circ C$ , unless otherwise noted			
Parameter	Symbol	Value	Unit
Drain-Source Voltage	$V_{DSS}$	100	V
Continuous Drain Current	$I_D$	55	A
Pulsed Drain Current (note1)	$I_{DM}$	220	A
Gate-Source Voltage	$V_{GSS}$	$\pm 20$	V
Power Dissipation	$P_D$	74	W
Single pulse avalanche energy (note3)	$E_{AS}$	72	mJ
Operating Junction and Storage Temperature Range	$T_J, T_{stg}$	-55 To 150	$^\circ C$
<b>Thermal Resistance</b>			
Parameter	Symbol	Value	Unit
Thermal Resistance, Junction-to-Case	$R_{thJC}$	1.7	$^\circ C/W$

Specifications $T_J = 25^\circ\text{C}$ , unless otherwise noted						
Parameter	Symbol	Test Conditions	Value			Unit
			Min.	Typ.	Max.	
<b>Static Parameters</b>						
Drain-Source Breakdown Voltage	$V_{(BR)DSS}$	$V_{GS} = 0V, I_D = 250\mu A$	100	--	--	V
Zero Gate Voltage Drain Current	$I_{DSS}$	$V_{DS} = 100V, V_{GS} = 0V, T_J = 25^\circ\text{C}$	--	--	1	$\mu A$
Gate-Source Leakage	$I_{GSS}$	$V_{GS} = \pm 20V$	--	--	$\pm 100$	nA
Gate-Source Threshold Voltage	$V_{GS(th)}$	$V_{DS} = V_{GS}, I_D = 250\mu A$	1.0	1.7	2.5	V
Drain-Source On-Resistance	$R_{DS(on)}$	$V_{GS} = 10V, I_D = 35A$	--	8	10.5	m $\Omega$
		$V_{GS} = 4.5V, I_D = 35A$	--	11	15	
Forward Transconductance	$g_{FS}$	$V_{DS}=5V, I_D=35A$	--	45	--	S
<b>Dynamic Parameters</b>						
Input Capacitance	$C_{iss}$	$V_{GS} = 0V,$ $V_{DS} = 50V,$ $f = 1.0\text{MHz}$	--	1625	--	pF
Output Capacitance	$C_{oss}$		--	666	--	
Reverse Transfer Capacitance	$C_{rss}$		--	14	--	
Total Gate Charge	$Q_g$	$V_{DD} = 50V,$ $I_D = 30A,$ $V_{GS} = 10V$	--	54	--	nC
Gate-Source Charge	$Q_{gs}$		--	10	--	
Gate-Drain Charge	$Q_{gd}$		--	14	--	
Turn-on Delay Time	$t_{d(on)}$	$V_{DD} = 50V,$ $I_D = 30A,$ $R_G = 1.6\Omega$	--	13	--	ns
Turn-on Rise Time	$t_r$		--	10	--	
Turn-off Delay Time	$t_{d(off)}$		--	30	--	
Turn-off Fall Time	$t_f$		--	8	--	
<b>Drain-Source Body Diode Characteristics</b>						
Continuous Body Diode Current	$I_S$	$T_C = 25^\circ\text{C}$	--	--	55	A
Body Diode Voltage	$V_{SD}$	$T_J = 25^\circ\text{C}, I_{SD} = 35A, V_{GS} = 0V$	--	--	1.2	V
Reverse Recovery Charge	$Q_{rr}$	$I_F=30A, di/dt=100A/us$	--	95	--	nC
Reverse Recovery Time	$T_{rr}$		--	45	--	ns

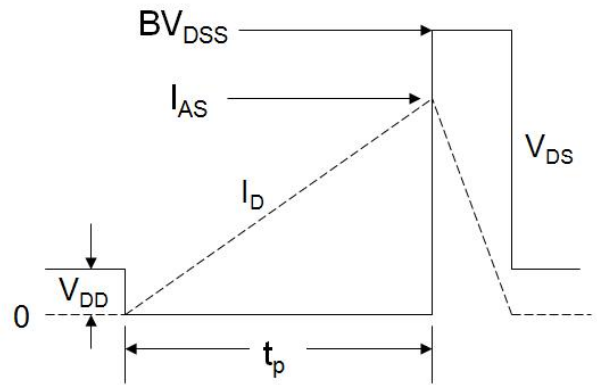
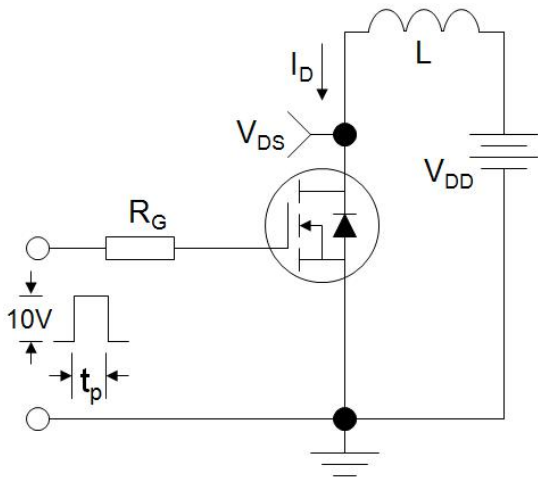
**Notes**

1. Repetitive Rating: Pulse width limited by maximum junction temperature
2. Identical low side and high side switch with identical  $R_G$
3. EAS condition :  $T_J=25, V_{DD}=50V, V_G=10V, L=0.5mH, R_g=25\Omega$

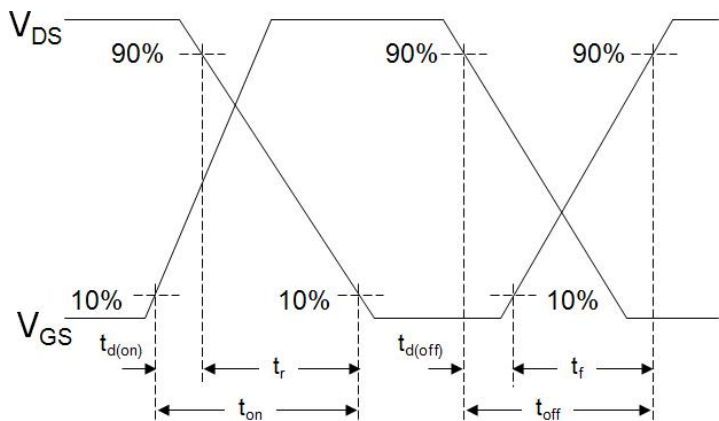
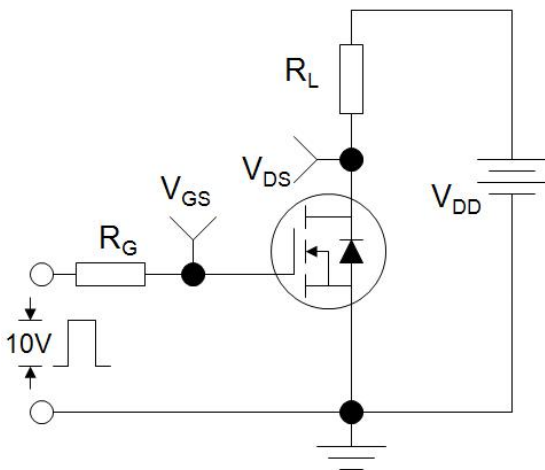
Gate Charge Test Circuit



EAS Test Circuit

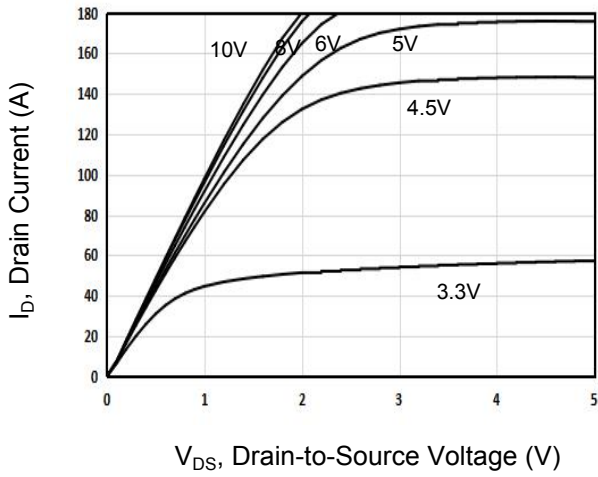


Switch Time Test Circuit

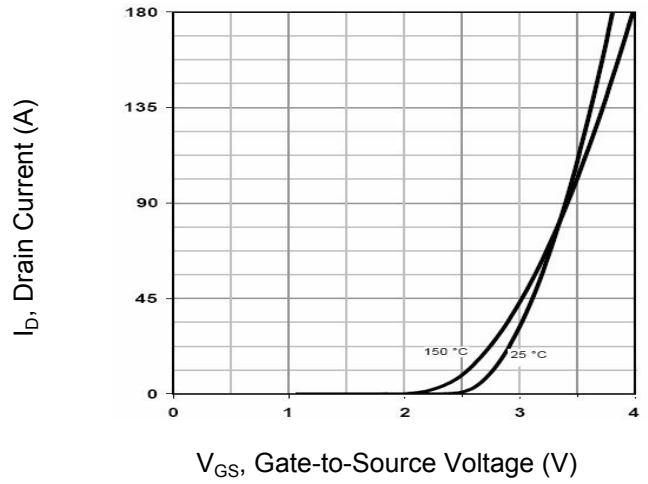


Typical Characteristics  $T_J = 25^\circ\text{C}$ , unless otherwise noted

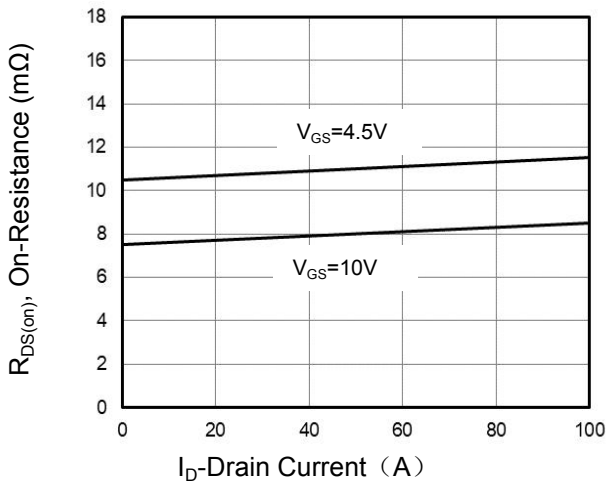
**Figure 1. Output Characteristics**



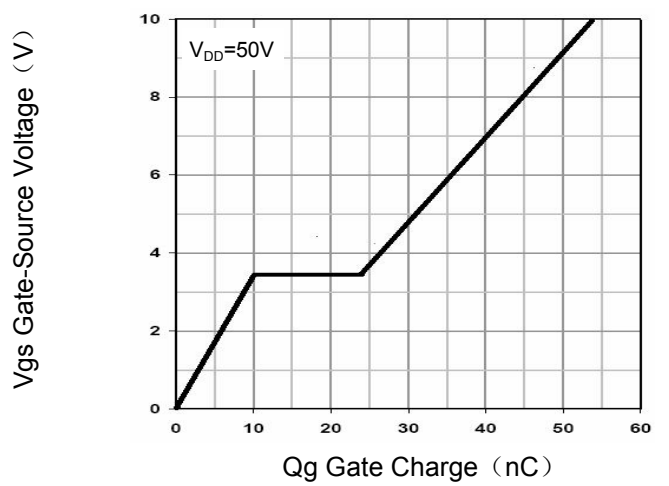
**Figure 2. Transfer Characteristics**



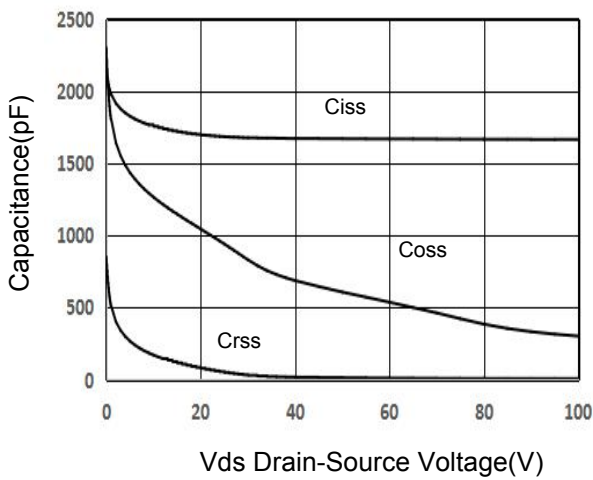
**Figure 3. Rdson-Drain Current**



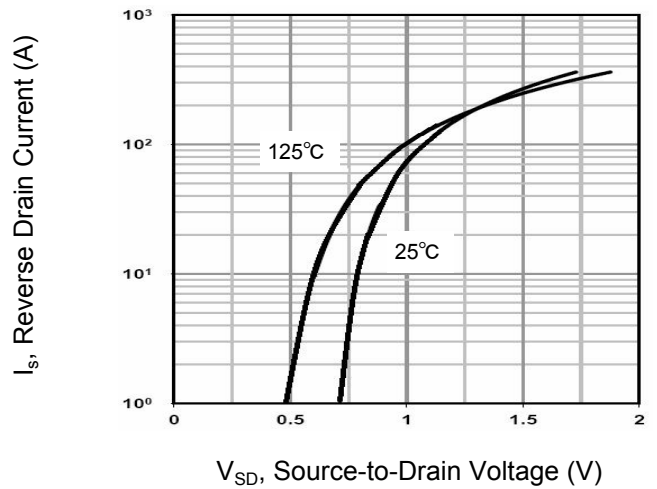
**Figure 4. Gate Charge**



**Figure 5. Capacitance vs Vds**

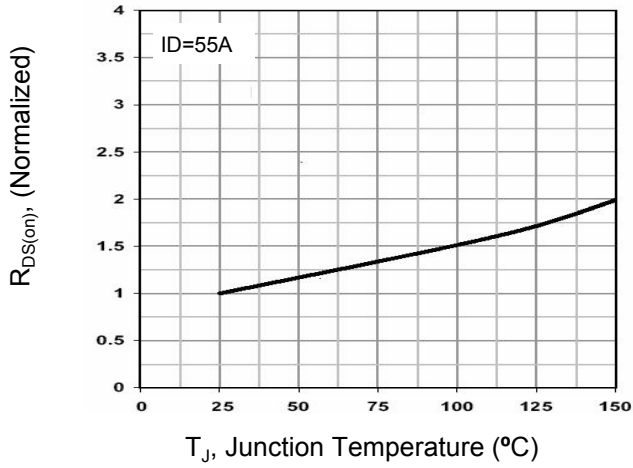


**Figure 6. Source-Drain Diode Forward**

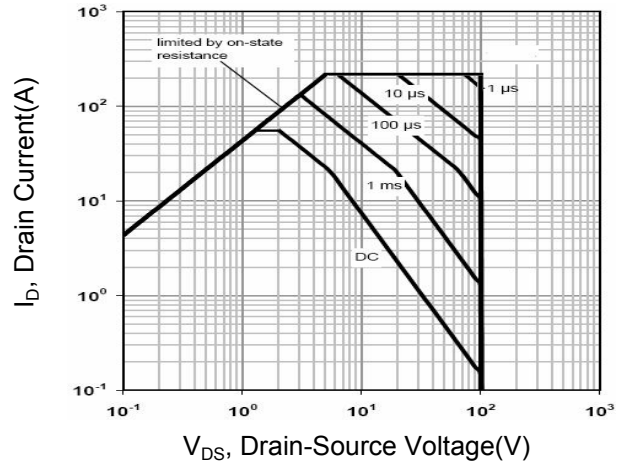


**Typical Characteristics**  $T_J = 25^\circ\text{C}$ , unless otherwise noted

**Figure 7. Drain-Source On-Resistance**



**Figure 8. Safe Operation Area**



**Figure 9. Normalized Maximum Transient Thermal Impedance**

