

TLE5046iC

Technical product description

High End GMR Wheel Speed Sensor with direction detection, ASIL B(D)

About this document

Scope and purpose

High-level description of the product features and technical characteristics as primary information about the functionality of the TLE5046iC High End GMR Wheel Speed Sensor with direction detection, ASIL B(D)

Intended audience

Automotive suppliers interested in wheel speed sensor applications

About this product

Description

Infineon's TLE5046iC is a wheel speed sensor with direction detection designed for sophisticated vehicle control systems. TLE5046iC shows best-in-class jitter performance, thus being the best choice for wheel speed applications. The rotational speed is sensed with high accuracy, enabling the sensor to be used as a component of indirect tire pressure monitoring systems (iTPMS). It is based on integrated giant magneto resistance (iGMR). Excellent sensitivity to magnetic field is specified over a wide temperature range. To meet harsh automotive requirements, robustness to electrostatic discharge (ESD) and electromagnetic compatibility (EMC) was maximized without the need of additional external components.

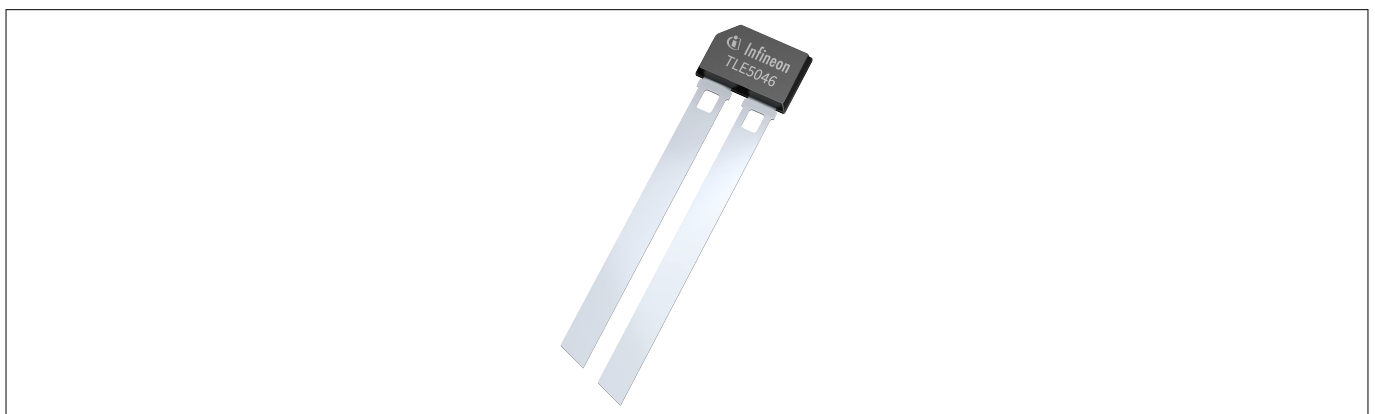

Figure 1 **Product photo**

About this product

Features & Benefits

- Developed according to ISO 26262, compliant with the requirements of ASIL B(D)
- Low jitter 0.02% due to high switching accuracy enables iTPMS
- Two-wire current interface providing speed and direction information
- Advanced stop-start capabilities enabled by
 - Innovative watchdog concept to guarantee maximum signal availability
 - No loss of direction information during start-stop condition
- Wide operating junction temperature range -40°C to 190°C
- Robustness against external magnetic disturbances up to 2mT through differential sensing principle
- High sensitivity enables outstanding air gap performance along with immunity against y-displacement effects
- Small sensor package 5x3mm without need of external capacitor saves module size, increases robustness against mechanical stress, and enables design freedom
- Advanced EMC concept maximizes the availability of the sensor signal
- New established Micro Break feature designed to be immune against disturbances on supply line

Order Information

Table 1

Type	Description	Ordering Number
TLE5046iC-PWM2-R050	Speed sensor with direction detection and PWM protocol, optimized for use with load resistor $R_m \leq 50 \Omega$	SP002627824
TLE5046iC-PWM2-R100	Speed sensor with direction detection and PWM protocol, optimized for use with load resistor $50 \Omega \leq R_m \leq 100 \Omega$	SP002627830
TLE5046iC-PWM2E-R050	Speed sensor with direction detection, additional self-diagnostics, and PWM protocol, optimized for use with load resistor $R_m \leq 50 \Omega$	SP002627816
TLE5046iC-PWM2E-R100	Speed sensor with direction detection, additional self-diagnostics, and PWM protocol, optimized for use with load resistor $50 \Omega \leq R_m \leq 100 \Omega$	SP002627820
TLE5046iC-AK-LR	Speed sensor with direction detection and AK protocol	SP001418756
TLE5046iC-AK-ERR	Speed sensor with direction detection, additional self-diagnostics, and AK protocol	SP001615796

Table of contents

	About this document	1
	About this product	1
	Table of contents	3
1	Product Characteristics	4
2	Functional Description	6
3	PWM Protocol	7
4	AK Protocol	8
5	Safety Mechanisms	8
6	ESD and EMC Characteristics	9
7	ESD HBM Model	9
8	Product Qualification	9
9	Pin Configuration	10
10	Package Outline	11
11	Terminology	12
	Revision history	13
	Disclaimer	14

1 Product Characteristics

1 Product Characteristics

Absolute Maximum Ratings

Stresses above the maximum values listed here may cause permanent damage to the device.

Table 2

Parameter	Symbol	Min.	Typ.	Max.	Unit	Note / Test Condition
Supply voltage	V_{DD}	-	-	24	V	max. 30 min @ $T_J = 25 \pm 5^\circ\text{C}$
		-0.6	-	-	V	$T_J < 80^\circ\text{C}$, I_{DD} reverse current limit applies
Reverse current	I_{DD}	-200	-	-	mA	t = max 4 h
Junction temperature	T_J	-40	-	190	$^\circ\text{C}$	max 4 h, < 16.5 V
Magnetic flux density	B_{max_x}	-	-	250	mT	max. 1min @ $T_A \leq 85^\circ\text{C}$
	B_{max_y}	-	-			
	B_{max_z}	-	-	500	mT	max. 1min @ $T_A \leq 85^\circ\text{C}$

Operating Range

The following operating conditions must not be exceeded in order to ensure correct operation.

Table 3

Parameter	Symbol	Min.	Typ.	Max.	Unit	Note / Test Condition
Supply voltage	V_{DD}	5.2	-	20	V	TLE5046iC-AK*, TLE5046iC-PWM*-R100
	V_{DD}	4.25	-	20	V	TLE5046iC-PWM*-R050
Operating Temperature	T_J	-40		190	$^\circ\text{C}$	
Magnetic signal frequency	f_{mag}	0	-	3000	Hz	
Minimum differential magnetic input signal amplitude, magnetic encoder application	dB_{limit_x} $T_A = 25^\circ\text{C}$	70	90	110	μT	99% criterium
Magnetic induction amplitude at each GMR sensing element	B_x	-25	-	25	mT	
Dynamic and static homogeneous external disturbance fields	$B_{\text{ext}_{XYZ}}$	-2		2	mT	no unwanted pulses

1 Product Characteristics

Functional Parameters

The magnetic input is assumed sinusoidal with constant amplitude and offset. The typical values shown below are valid for $V_{DD} = 12\text{ V}$ and $T_A = 25^\circ\text{C}$. For a more detailed specification please refer to our product datasheets which are available on request.

Table 4

Parameter	Symbol	Min.	Typ.	Max.	Unit	Note / Test Condition
Period jitter	S_{jit}	-	± 0.02		%	$\pm 1\sigma$ value
Duty cycle	DC	40	-	60	%	in calibrated mode
Supply current during static output low state	I_{low}	5.95	7	8.05	mA	
Supply current during static output mid state (AK), or high state (PWM)	I_{mid} I_{high}	11.9	14	16.1	mA	
Supply current during static output high state (AK)	I_{high}	23.8	28	32.2	mA	
Current level for indicating errors	I_{Error}	1	3.5	3.8	mA	
Output current slew rate	SR_r, SR_f	11	-	28	mA/ μs	$SR_r = (I_{90\%} - I_{10\%}) / t_r$ $SR_f = (I_{90\%} - I_{10\%}) / t_f$
Switch-off voltage	V_{reset}			3.5	V	direct on sensor pins
Supply voltage hysteresis	V_{Hys}	1.5		1.7	V	TLE5046iC-AK*, TLE5046iC-PWM*-R100
Supply voltage hysteresis	V_{Hys}	0.65		0.75	V	TLE5046iC-PWM*-R050

2 Functional Description

2 Functional Description

The sensor element has a magnetic interface to detect the increments of a magnetized encoder: the sensing principle is based on the giant magneto resistance (GMR) principle sensitive to magnetic fields in x-direction. It is designed for maximum sensitivity and suppression of homogeneous fields.

In the figure below the typical placement of the TLE5046iC facing a magnetic encoder wheel is shown. The figure also indicates the coordinate system, which is valid throughout this document.

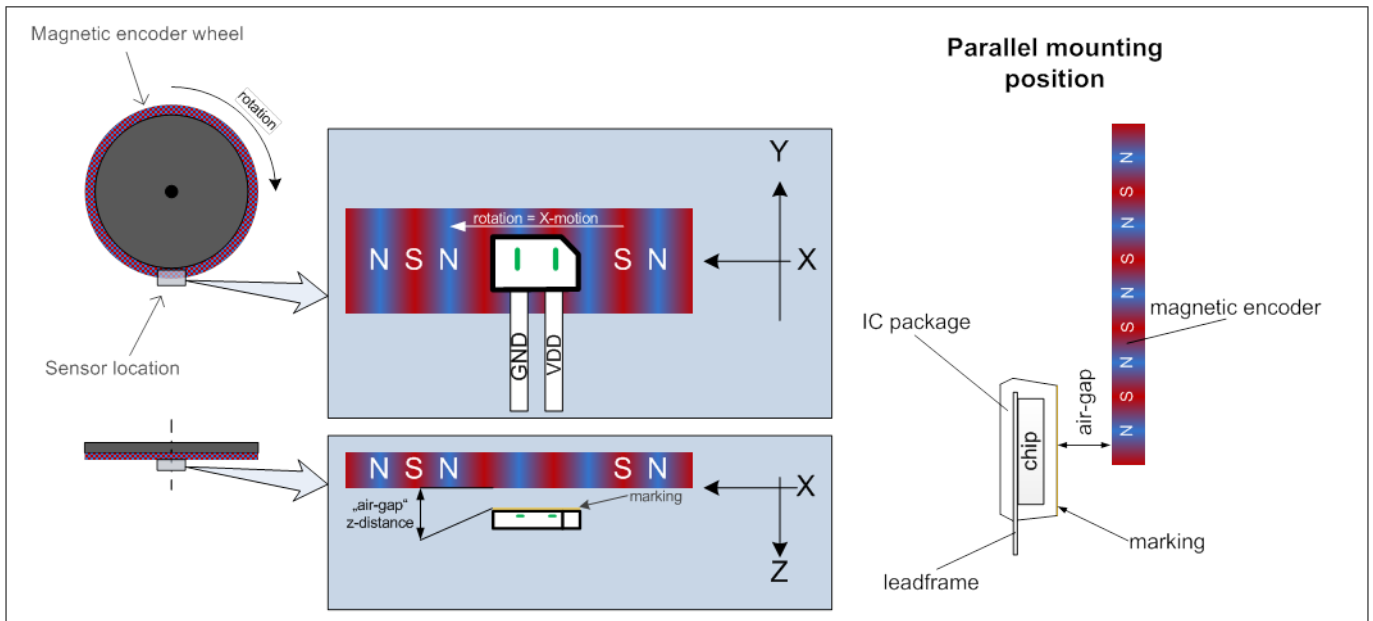

Figure 2 Typical placement of the TLE5046iC

3 PWM Protocol

3 PWM Protocol

The output has been designed as a two-wire current interface based on a Pulse Width Modulation principle. Each zero crossing of the magnetic input signal triggers an output pulse indicated by I_{High} and I_{Low} current consumption.

The PWM Protocol is available in two different protocol options: standard TLE5046iC-PWM2 and TLE5046iC-PWM2E with indication of internal errors by using the warning pulse.

The timing characteristic for TLE5046iC-PWM2 and TLE5046iC-PWM2E is given in the table below:

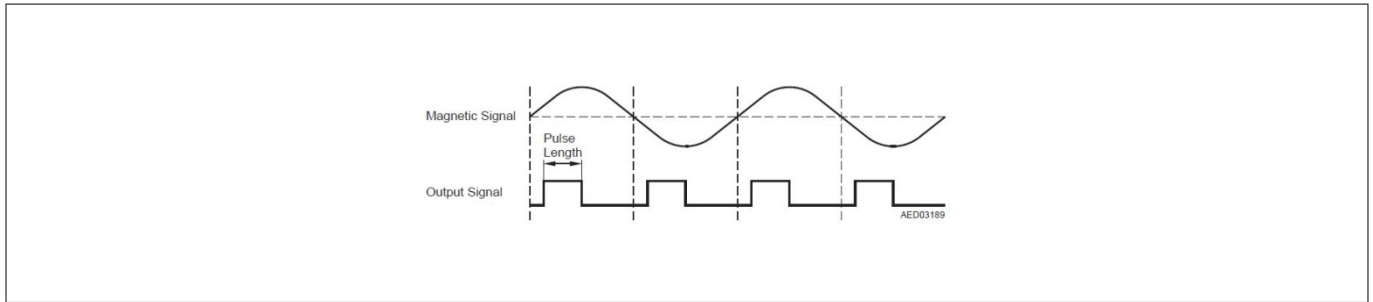

Figure 3 Signal output pulse

The timing characteristic for TLE5046iC-PWM2 and TLE5046iC-PWM2E is given in the table below:

Table 5

Parameter	Symbol	Min.	Typ.	Max.	Unit	Note / Test Condition
Pre-low length	$t_{pre-low}$	38	45	52	μs	
Length of Warning pulse	$t_{Warning}$	38	45	52	μs	
Length of DR-L pulse	t_{DR-L}	76	90	104	μs	
Length of DR-R pulse	t_{DR-R}	153	180	207	μs	
Length of DR-L & EL pulse	$t_{DR-L\&EL}$	306	360	414	μs	
Length of DR-R & EL pulse	$t_{DR-R\&EL}$	616	720	828	μs	
Output of EL pulse, maximum frequency	f_{ELmax}	-	117	-	Hz	
Length of stand still pulse	t_{Stop}	1.232	1.4	1.656	ms	
Stand still period	T_{Stop}	590	737	848	ms	
ΔB_{EL}	ΔB_{EL}		345		mT	$4 * \Delta B_{limit}$
$\Delta B_{Warning}$	$\Delta B_{Warning}$		160		mT	$2 * \Delta B_{limit}$

4 AK Protocol

4 AK Protocol

TLE5046iC-AK-LR and TLE5046iC-AK-ERR devices are compliant with: “Requirement Specifications for Standardized Interface for Wheel Speed Sensors with Additional Information ‘AK-Protocol’ Version: 4.0” dated 13.02.2008 of Daimler AG, unless otherwise stated in this document or in the valid Technical Datasheets.

The following illustration defines the meaning of the data protocol. The bits 0 - 8 in the illustration are designated as the data protocol and their purpose is to transfer additional information to the speed pulse.

Bit position #0 can be used as an indication for air gap reserve (LR), or can be interpreted by the ECU as an “error bit” and treated in a special way (ERR). The two different variants TLE5046iC-AK-LR and TLE5046iC-AK-ERR, respectively, perform accordingly.

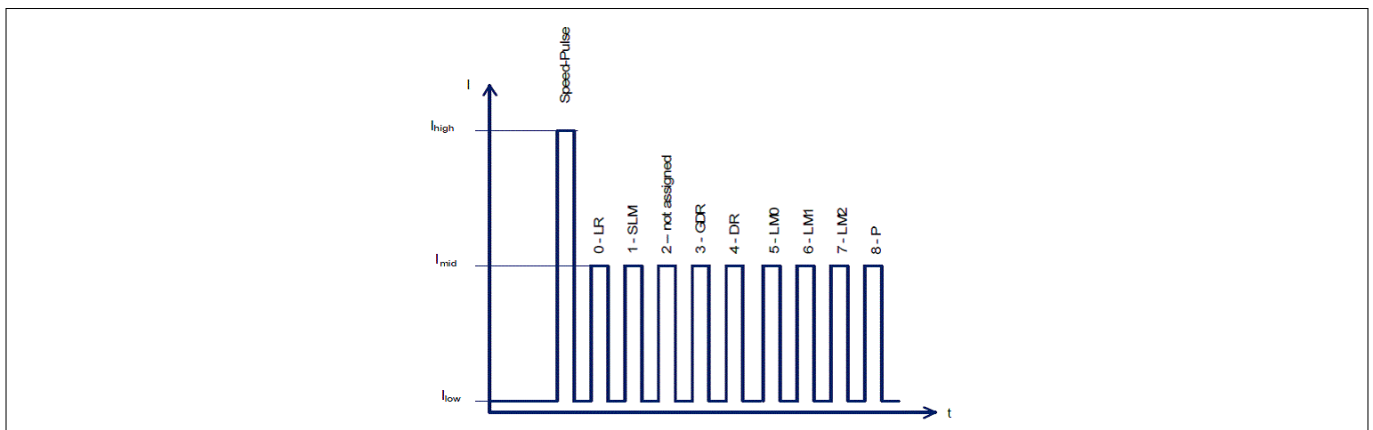

Figure 4 Data protocol

5 Safety Mechanisms

The TLE5046iC offers safety features to support the Automotive Safety Integrity Level ASIL B and is designed to be used in ASIL D systems.

An embedded safety concept was developed to notify the Control System in case of an internal error by setting the output current level to a constant failure indication level I_{Error} .

An embedded safety concept was developed to minimize the effect of hard and soft random errors by the introduction of specific safety mechanisms. In case of an internal error a notification to the ECU is transmitted by either setting the output current level to a constant failure indication level I_{Error} or transmitting an error flag via the protocol.

Following safety mechanisms have been implemented:

- Undervoltage detection: This safety mechanism detects voltage drops to values where the correct functionality of the circuitry is no more ensured. The sensor remains in this state until the error condition is solved and V_{DD} is back into normal operating range.
- Detection of discrepancy between number of active fuses and internally stored number of fuses: This safety mechanism compares the active fuse bits against the internal stored quantity. The sensor remains in this failure indication state I_{Error} until the device is powered off and on again and the error condition is not present any longer.
- Detection of clock malfunction: This safety mechanism forces the failure indication state if the clock is either stuck or below 25% of the nominal value
- Detection of different numbers between speed and direction path: This safety mechanism verifies if more than two consecutive electric events are generated without any detected event in the direction path or vice versa
- Detection of critical air gap, ADC clipping and temperature monitoring: This safety mechanisms verifies critical states inside the ASIC itself.

6 ESD and EMC Characteristics

The full overview including detailed descriptions of the functionality of each safety mechanism and the detailed failure reaction can be found in the Safety Manual.

The entirety of Infineon experience has been used to identify and prevent common cause of failure in the application including EMC disturbances and mechanical tolerances. An advanced EMC concept, inclusive of microbreak feature, without the need of external components, maximizes the availability of the sensor signal at the electrical interface. Also, the speed algorithm is designed for fast start-up and optimization of duty cycle. The extremely low jitter of the sensor contributes to high time accuracy of the speed signal.

TLE5046iC is accompanied by accurate safety analysis and complete documentation to enable the system integrator to quickly evaluate the compatibility with the system/item and start the integration process. A detailed description of how the sensor is to be used in an ISO26262 compliant system can be found in the Safety Manual and Safety Analysis Summary Report, which are available on request.

6 ESD and EMC Characteristics

The TLE5046iC is characterized according to the IC level EMC requirements described in the “Generic IC EMC Test Specification” Version 2.0 from 2014. EMC testreport is available on request.

Additionally component level EMC characterizations are performed according to ISO 7637-2:2011, ISO 7637-3:2007 and ISO 16750-2:2010 regarding pulse immunity, and CISPR 25 (2009-01) Ed. 3.0 regarding conducted emissions.

7 ESD HBM Model

Table 6

Parameter	Symbol	Min.	Typ.	Max.	Unit	Note / Test Condition
ESD Voltage	V _{HBM}	-	-	±12	kV	Method AEC-Q100 Rev H (1.5 kΩ, 100 pF)

8 Product Qualification

Product qualification according to AEC-Q100 Grade 0 is performed.

9 Pin Configuration

9 Pin Configuration

Table 7

Pin No.	Symbol	Function
1	VDD	Supply voltage
2	GND	Ground

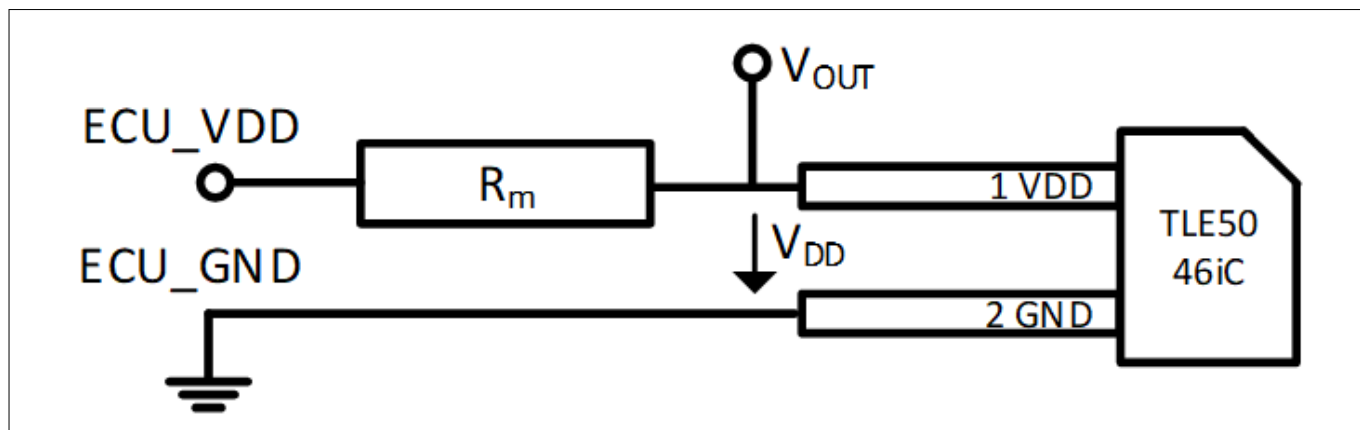

Figure 5 Pin configuration

10 Package Outline

10 Package Outline

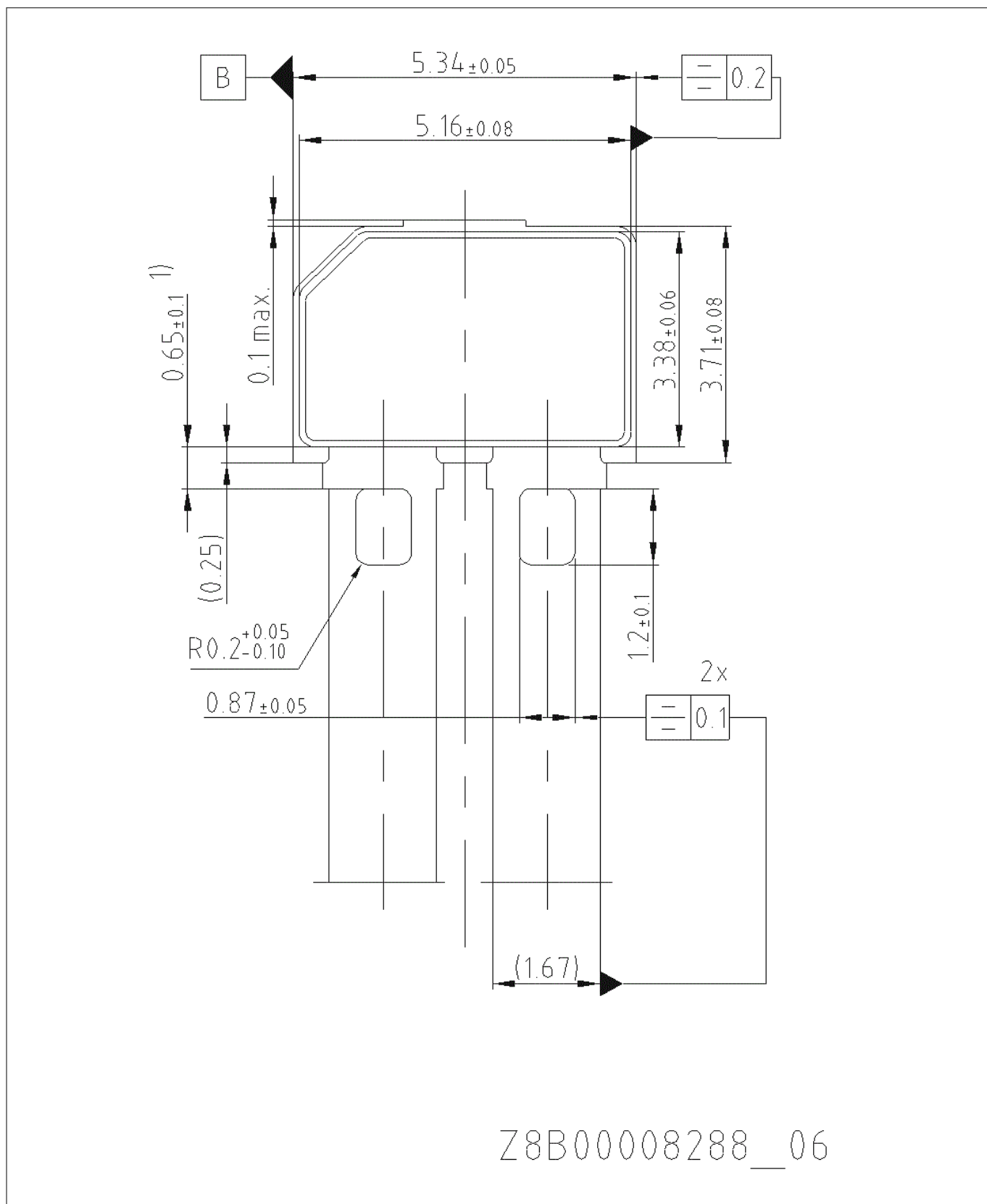

Figure 6 Package Outline

11 Terminology

11 Terminology

Table 8

μs	microsecond
μT	micro-Tesla
A	Ampere
AEC	Automotive Electronics Council
AK	Arbeitskreis
ASIC	application specific integrated circuit
ASIL	automotive safety integrity Level
C	Celsius
CISP	Comité international spécial des perturbations radioélectriques
EMC	electromagnetic compatibility
ESD	electrostatic discharge
GMR	giant magneto resistance
GND	ground
h	hour
HBM	human body model
Hz	Hertz
IC	integrated circuit
iGMR	integrated giant magneto resistance
ISO	International Organization for Standardization
iTPMS	integrated tire pressure monitoring system
kΩ	kilo-Ohm
kV	kilo-Volt
mA	milli-Ampere
min	minute
mm	millimeter
ms	millisecond
mT	milli-Tesla
Ω	Ohm
pF	picofarad
PWM	pulse width modulation
V	Volt
VDD	supply voltage

Revision history

Revision history

Document version	Date of release	Description of changes
1.0	2018-11-06	<ul style="list-style-type: none">Initial version
2.0	2020-06-30	<ul style="list-style-type: none">PWM protocol changed to PWM2

Trademarks

All referenced product or service names and trademarks are the property of their respective owners.

Edition 2020-06-30

Published by

Infineon Technologies AG

81726 Munich, Germany

© 2020 Infineon Technologies AG

All Rights Reserved.

Do you have a question about any aspect of this document?

Email: erratum@infineon.com

Document reference

IFX-lbs1538409505925

IMPORTANT NOTICE

The information given in this document shall in no event be regarded as a guarantee of conditions or characteristics ("Beschaffheitsgarantie").

With respect to any examples, hints or any typical values stated herein and/or any information regarding the application of the product, Infineon Technologies hereby disclaims any and all warranties and liabilities of any kind, including without limitation warranties of non-infringement of intellectual property rights of any third party.

In addition, any information given in this document is subject to customer's compliance with its obligations stated in this document and any applicable legal requirements, norms and standards concerning customer's products and any use of the product of Infineon Technologies in customer's applications.

The data contained in this document is exclusively intended for technically trained staff. It is the responsibility of customer's technical departments to evaluate the suitability of the product for the intended application and the completeness of the product information given in this document with respect to such application.

WARNINGS

Due to technical requirements products may contain dangerous substances. For information on the types in question please contact your nearest Infineon Technologies office.

Except as otherwise explicitly approved by Infineon Technologies in a written document signed by authorized representatives of Infineon Technologies, Infineon Technologies' products may not be used in any applications where a failure of the product or any consequences of the use thereof can reasonably be expected to result in personal injury.