



Features

- Preset 8.4V Charge Voltage with 1% Accuracy
- Programmable Charge Current up to 1A
- Input Voltage: 9V ~ 13V
- Pre-Charging, the Charge Current is adjustable
- Ideal for Dual-Cell (8.4V) Li-Ion Batteries
- Constant-Current Charging, the Charge Current is adjustable
- Constant-Voltage Charging
- Constant-Current/Constant-Voltage Charging with Temperature Monitoring
- Automatic Recharge
- Double LEDs Charge Status Indication
- Available in SOP-8L Package

Applications

- Charger for Li-Ion Coin Cell Batteries
- Portable MP3 Players, Wireless Headsets
- Multifunction Wristwatches
- Bluetooth Applications

Description

The HX6017 is a complete constant current/constant voltage linear charger for cell lithium-ion batteries. Its package and low external component count make the HX6017 ideally suited for portable applications. The charge current can be programmed externally with a single resistor. HX6017 determines the charge mode by detecting the battery voltage: Pre-charge, constant current charging, constant voltage charging. The charge current of pre-charging and constant-current charging is adjustable. The HX6017 is monitored by temperature monitor during the constant-current and constant-voltage charging. There are two LEDs indicate the charge mode.

The HX6017 is available in the SOP-8L package (or upon request).

Typical Application Circuit

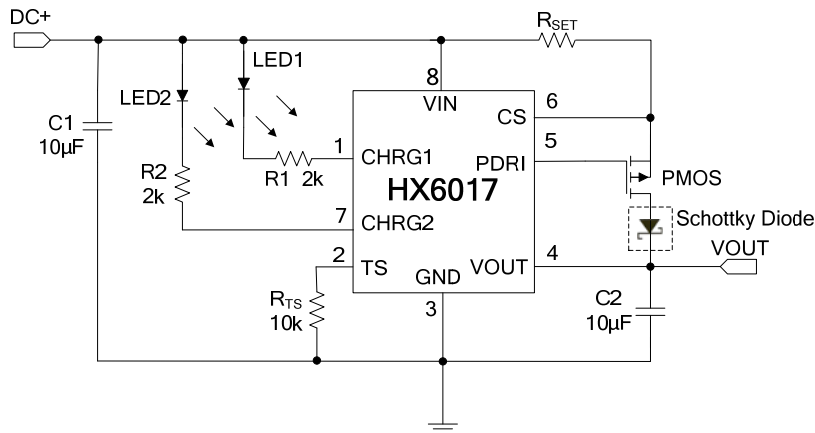

*The charge current $I_{O(REG)} = V_{CS}/R_{SET}$ (V_{CS} is usually 200mV). Note that OFF indicates the open-drain transistor is turned off.

*The reverse-blocking protection diode is optional. In addition, the reverse-leakage current of the diode should be kept as small as possible.

Pin Assignment and Description

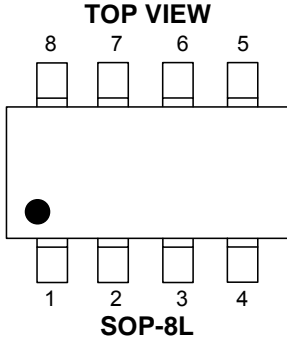
TOP VIEW	PIN	NAME	DESCRIPTION
		1	CHRG1
	2	TS	Temperature Sense
	3	GND	Ground
	4	VOUT	Charge Current Output
	5	PDR1	Charge Current Monitor and Shutdown Pin
	6	CS	Charge Current Program
	7	CHRG2	Open-Drain Charge Status Output
	8	VIN	Positive Input Supply Voltage.

Absolute Maximum Ratings (Note 1)

- Input Supply Voltage (VIN)-0.3V ~ 15V
- TS, CHRG1, CHRG2, PDR1, CS-0.3V ~ VIN+0.3V
- VOUT Pin Current 1A
- Maximum Junction Temperature +150°C
- Operating Ambient Temperature Range (Note 2)..... -40°C ~ +85°C
- Storage Temperature Range-65°C ~ +125°C
- Lead Temperature (Soldering, 10 sec).....+265°C

Note 1: Stresses listed as the above “Absolute Maximum Ratings” may cause permanent damage to the device. Exposure to absolute maximum rating conditions for extended periods may remain possibility to affect device reliability.

Note 2: The HX6017 is guaranteed to meet performance specifications from 0°C to 70°C. Specifications over the -40°C to 85°C operating temperature range are assured by design, characterization and correlation with statistical process controls.

Electrical Characteristics

Operating Conditions: $T_A=25^{\circ}\text{C}$, unless otherwise specified.

SYMBOL	PARAMETER	CONDITIONS	MIN	TYP	MAX	UNITS
V_{IN}	Input Supply Voltage		9		13	V
I_{IN}	Input Supply Current	Standby Mode (Charge Terminated) I		0.25		mA
I_{SLEEP}	Sleep Current	Sum of currents into VOUT pin, $V_{IN}=0$		25		μA
Battery Voltage Regulation Constant-current Charge						
$V_{O(REG)}$	Output voltage		8.317	8.4	8.484	V
$V_{(CS)}$	Current regulation threshold	Voltage at pin CS, relative to V_{IN}	180	200	220	mV
Trickle Charge						
V_{TRIKL}	Trickle Charge Threshold Voltage	$V_{BAT} < V_{TRIKL}$, $R_{SET}=0.33\Omega$.	5.6	6	6.2	V
I_{TRIKL}	Trickle Charge Current	V_{BAT} Rising, $R_{SET}=0.33\Omega$.		60		mA
V_{RCH} comparator (Battery Recharge Threshold)						
$V_{(RCH)}$	Recharge Battery Threshold Voltage	$V_{FLOAT} - V_{RECHRG}$		$V_{O(REG)} - 400\text{mV}$		V
Temperature Sense Comparator						
$V_{TS-COLD}$	TS Pin Threshold Voltage (Cold)	V_{TS} from Low to High		2.486		V
V_{TS-HOT}	TS Pin Threshold Voltage (Hot)	V_{TS} from High to Low		0.485		V
I_{TS}	TS Pin Output Current			85		μA

Pin Functions

CHRG1 (Pin 1): Charge Status Indication. When the battery is charging, the CHRG pin is pulled low. When the charge cycle is completed, the CHRG pin is pulled high. This PIN is available through a 2kohm resistor and indicates that the light-emitting diode connected.

TS (Pin 2): Temperature Sense.

GND (Pin 3): Ground.

VOUT (Pin 4): Charge Current Output. It should be bypassed with at least a 10 μ F capacitor. It provides charge current to the battery and regulates the final float voltage to 8.4V.

PDRI (Pin 5): Driving side. Connect to the grid of the PMOS.

CS (Pin 6): Charge Current Program, Charge Current Monitor and Shutdown Pin. The charge current is programmed by connecting a resistor, R_{SET} , $I_{SET} = V_{(CS)} / R_{SET}$.

CHRG2 (Pin 7): End-of-Charge Status Indication. When the battery is charging, the CHRG2 pin is forced high. When the charge cycle is completed, CHRG2 is pulled low.

VIN (Pin 8): Positive Input Supply Voltage. It Provides power to the charger VIN and should be bypassed with a 10 μ F capacitor.

Table1. Charge Status Summary

CONDITION	LED1	LED2
Battery charging	ON	OFF
Charge complete	OFF	ON

Application Information

Functional Description

The HX6017 is a high accuracy linear Li-Lon Battery Charger for dual-cell Li-Ion applications. Refer to Operation Flow Chart (Figure 1) in this section.

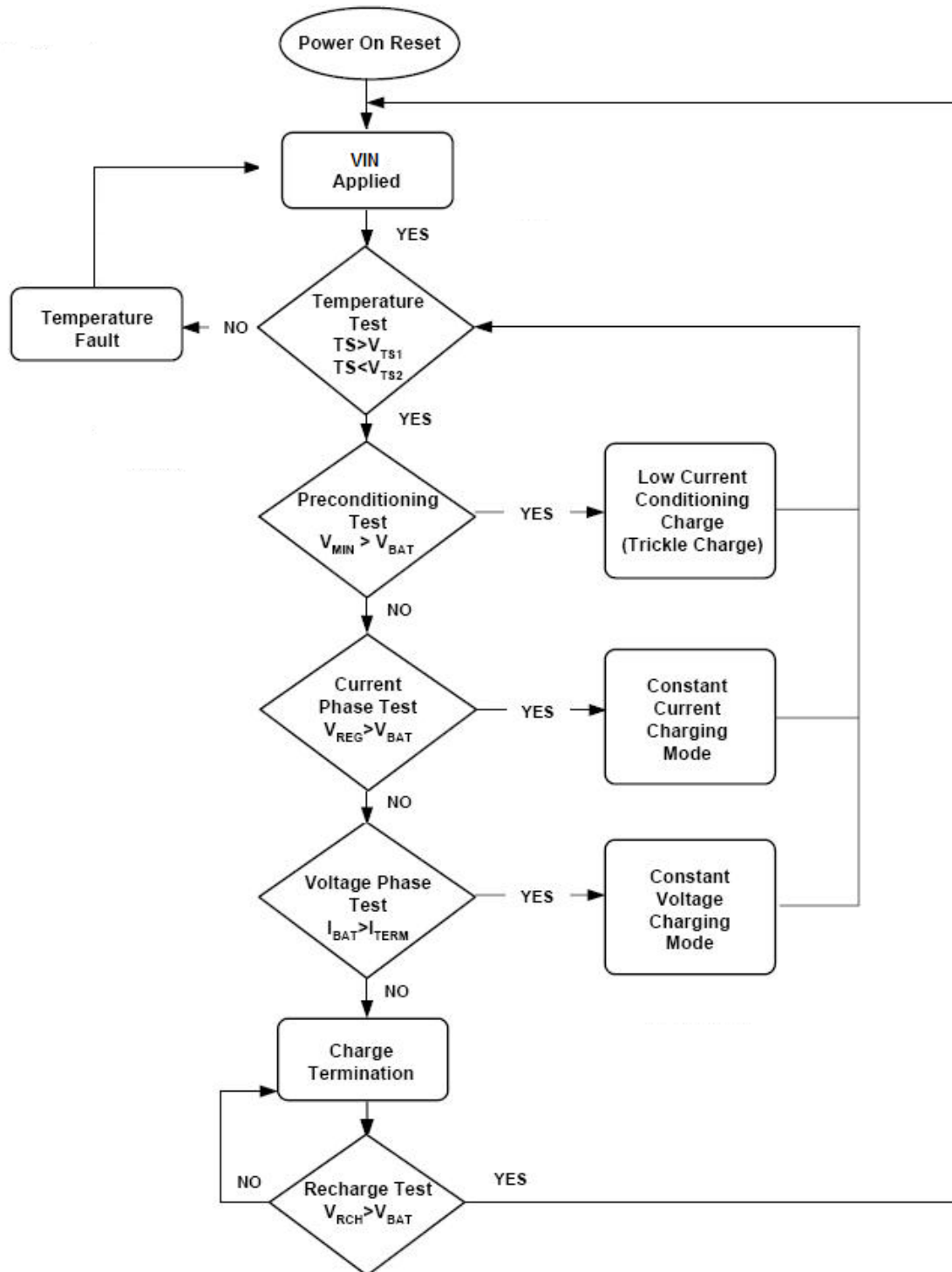

Figure 1: Operation Flow Chart

Qualification and Precharge

When power is applied, the HX6017 starts a charge-cycle if a battery is already present or when a battery is inserted. Charge qualification is based on battery temperature and voltage.

The HX6017 suspends charge if the battery temperature is outside the V_{TS1} to V_{TS2} range and suspends charge until the battery temperature is within the allowed range. The HX6017 also checks the battery voltage. If the battery voltage is below the precharge threshold $V_{(min)}$, the HX6017 uses precharge to condition the battery. The conditioning charge rate $I_{(PRECHG)}$ is set at approximately 10% of the regulation current. The conditioning current also minimizes heat dissipation in the external pass-element during the initial stage of charge. See Figure 3 for a typical charge-profile.

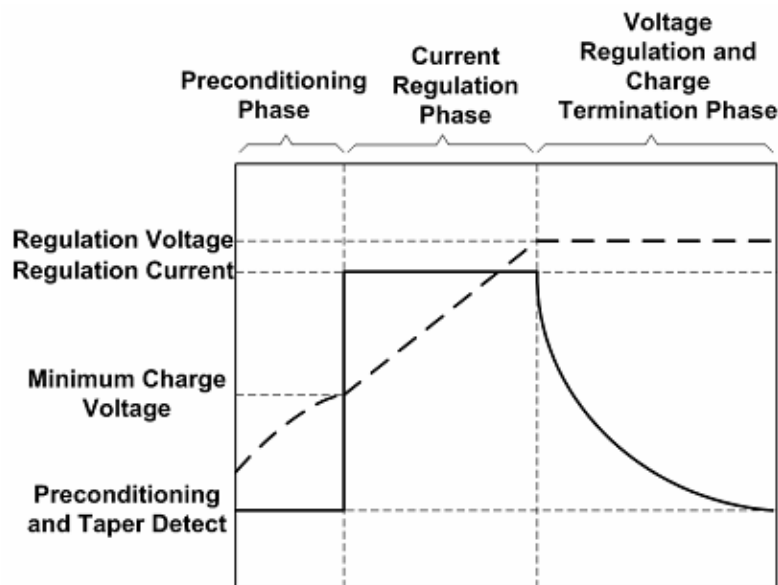

Figure 2: Typical Charge Profile

Current Regulation Phase

The HX6017 regulates current while the battery-pack voltage is less than the regulation voltage, $V_{O(REG)}$. The HX6017 monitors charge current at the CS input by the voltage drop across a sense-resistor, R_{SET} , in series with the battery pack. In current sensing configuration, R_{SET} is between the VIN and CS pins, charge-current feedback, applied through pin CS, maintains a voltage of V_{CS} across the current sense resistor. The following formula calculates the value of the Sense resistor:

$$R_{SET} = \frac{V_{CS}}{I_{REG}}$$

Where I_{REG} is the desired charging current.

Voltage Phase

The voltage regulation feedback is through the VOUT pin. This input is tied directly to the positive side of the battery pack. The HX6017 monitors the battery-pack voltage between the VOUT and GND pins. The HX6017 is offered 8.4V output voltage.

Charge Termination Recharge

The HX6017 monitors the charging current during the voltage-regulation phase. The HX6017 declares a done condition and terminates charge when the current drops to the charge termination threshold, I_{TERM} . A new charge cycle begins when the battery voltage falls below the V_{RCH} threshold.

Battery Temperature Monitoring

A negative temperature coefficient (NTC) thermistor located close to the battery pack can be used to monitor battery temperature and will not allow charging unless the battery temperature is within an acceptable range.

Connect a 10k Ω thermistor from the TS pin to ground. With the 85 μ A pull-up current source, the hot temperature voltage threshold is 485mV. For cold temperature, the voltage threshold is set at 2.486V with 85 μ A of pull-up current. The charge cycle begins or resumes once the temperature is within the acceptable range.

Reverse Blocking Protection

The optional reverse-blocking protection diode, depicted in Figure1 provides protection from a faulted or shorted input, or from a reversed-polarity input source. Without the protection diode, a faulted or shorted input would discharge the battery pack through the body diode of the external pass transistor.

If a reverse-protection diode is incorporated in the design, it should be chosen to handle the fast charge current continuously at the maximum ambient temperature. In addition, the reverse-leakage current of the diode should be kept as small as possible.

Selecting Input Capacitor

In most applications, all that is high-frequency decoupling capacitor. The HX6017 works with both regulated and unregulated external dc supplies. If a non-regulated supply is chosen, the supply voltage to the minimum required input voltage at maximum load. If not, more capacitance must be added to the input of the charger.

Selecting Output Capacitor

The HX6017 does not require any output capacitor for loop stability. In order to maintain good AC stability in constant Voltage mode, a minimum capacitance of 10 μ F is recommended to bypass the BAT pin to GND. This capacitance provides compensation when there is no battery load. In addition, the battery and interconnections appear inductive at high frequencies. These elements are in the control feedback loop during Constant Voltage mode. Therefore, the bypass capacitance may be necessary to compensate for the inductive nature of the battery pack.

Virtually any good quality output filter capacitor can be used, independent of the capacitor's minimum ESR (Effective Series Resistance) value. The actual value of the capacitor and its associated ESR depends on the forward transconductance (gm) and capacitance of the external pass transistor. A 10 μ F tantalum or aluminum electrolytic capacitor at the output is usually sufficient to ensure stability for up to a 1A output current.

Packaging Information

SOP-8L Package Outline Dimension

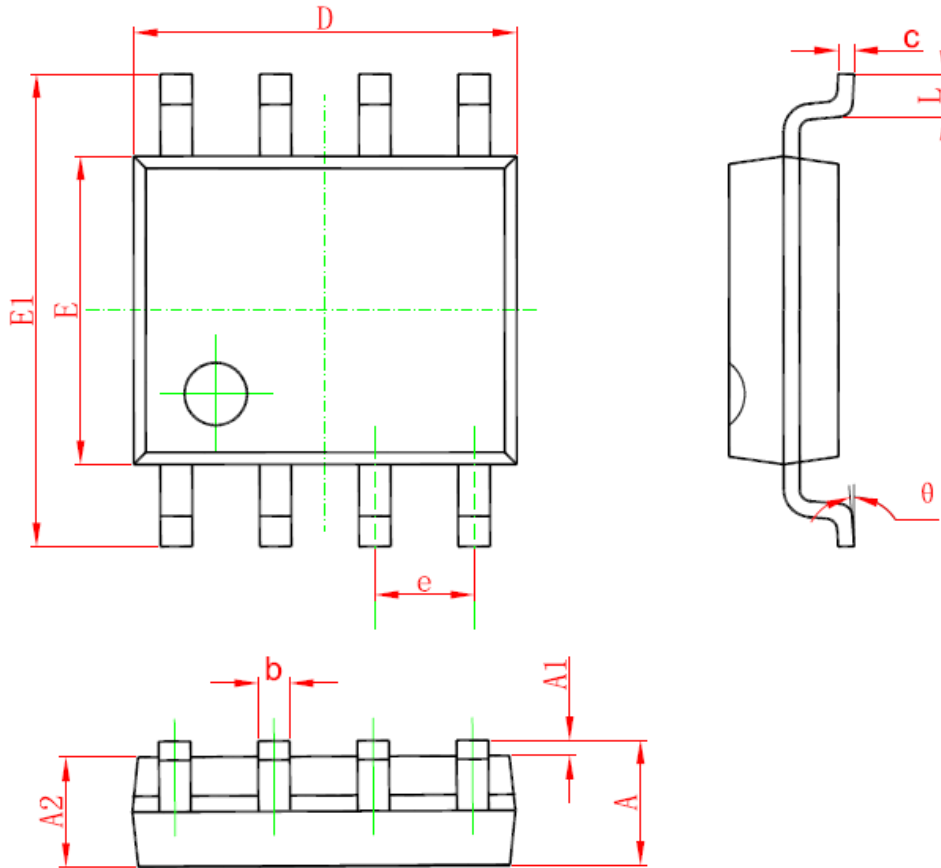

Symbol	Dimensions In Millimeters		Dimensions In Inches	
	Min	Max	Min	Max
A	1.350	1.750	0.053	0.069
A1	0.100	0.250	0.004	0.010
A2	1.350	1.550	0.053	0.061
b	0.330	0.510	0.013	0.020
c	0.170	0.250	0.006	0.010
D	4.700	5.100	0.185	0.200
E	3.800	4.000	0.150	0.157
E1	5.800	6.200	0.228	0.244
e	1.270(BSC)		0.050(BSC)	
L	0.400	1.270	0.016	0.050
θ	0°	8°	0°	8°

Subject changes without notice.