



Features

- Programmable Charge Current up to 800mA
- No MOSFET, Sense Resistor or Blocking Diode Required
- Constant-Current/Constant-Voltage Operation with Thermal Regulation to Maximize Charge Rate
- Without Risk of Overheating
- Charges Single Cell Li-Ion Batteries Directly from USB Port
- Preset 4.2V Charge Voltage with 1% Accuracy
- Automatic Recharge
- 2.9V Trickle Charge Threshold
- Available in DFN3*3-10L Package

Applications

- Charger for Li-Ion Coin Cell Batteries
- Portable MP3 Players, Wireless Headsets
- Bluetooth Applications
- Multifunction Wristwatches

Description

The HX6075 is a complete constant current/constant voltage linear charger for single cell lithium-ion batteries. Its package and low external component count make the HX6075 ideally suited for portable applications. Furthermore, the HX6075 is specifically designed to work within USB power specifications.

No external sense resistor is needed, and no blocking diode is required due to the internal MOSFET architecture. The charge voltage is fixed at 4.2V, and the charge current can be programmed externally with a single resistor. The HX6075 automatically terminates the charge cycle when the charge current drops to 1/10th the programmed value after the final float voltage is reached.

The HX6075 converters are available in the industry standard DFN3*3-10L power packages (or upon request).

Order Information

HX6075 - ① ②:

SYMBOL	DESCRIPTION
①	Denotes Output Voltage: N: 4.2V
②	Denotes Package Type: J: DFN3*3-10L

Typical Application Circuit

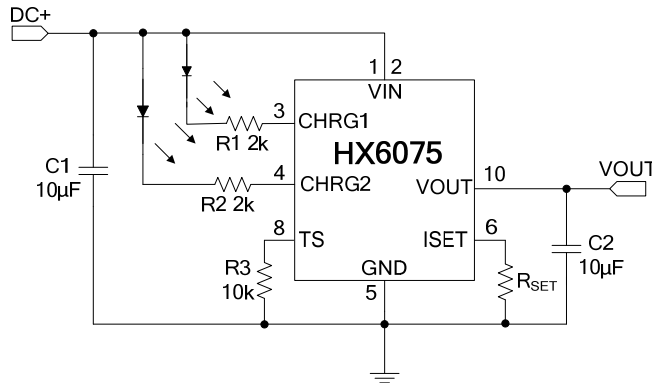

* $I_{OUT} = (V_{ISET}/R_{SET}) \cdot 900$.

* When charging in constant-current mode, the V_{ISET} is usually 1V.

Pin Assignment and Description

TOP VIEW		PIN	NAME	DESCRIPTION
<p>DFN3*3-10L *The exposed pad(Pin 11) must be soldered to a large PCB.</p>		1	VIN	Positive Input Supply Voltage.
		2	VIN	Positive Input Supply Voltage.
		3	CHRG1	Open-Drain Charge Status Output
		4	CHRG2	Open-Drain Charge Status Output
		5,11	GND	Ground
		6	ISET	Charge Current Set Point
		7,9	N/C	No Connect
		8	TS	Temperature Sense
		10	VOUT	Charge Current Output

Absolute Maximum Ratings (Note 1)

- Input Supply Voltage -0.3V ~ 7V
- CHRG1, CHRG2 Pin Voltage..... - 0.3V ~ VIN + 0.3V
- VOUT Pin Voltage..... -0.3V ~ 7V
- VOUT Pin Current 800mA
- ISET Pin Voltage..... -0.3V ~ 7V
- Operating Ambient Temperature Range (Note 2)..... -40°C ~ +85°C
- Maximum Junction Temperature..... +150°C
- Storage Temperature Range -65°C ~ +125°C
- Lead Temperature (Soldering, 10 sec)..... +265°C

Note 1: Stresses listed as the above “Absolute Maximum Ratings” may cause permanent damage to the device. Exposure to absolute maximum rating conditions for extended periods may remain possibility to affect device reliability.

Note 2: The HX6075 is guaranteed to meet performance specifications from 0°C to 70°C. Specifications over the -40°C to 85°C operating temperature range are assured by design, characterization and correlation with statistical process controls.

Electrical Characteristics

Operating Conditions: $T_A = 25^\circ\text{C}$, $V_{IN} = 5\text{V}$, unless otherwise specified.

SYMBOL	PARAMETER	CONDITIONS	MIN	TYP	MAX	UNITS
V_{IN}	Input Supply Voltage		4.5	5.0	5.5	V
I_{IN}	Input Supply Current	Standby Mode (Charge Terminated)		48		μA
		Shutdown Mode (R_{SET} Not Connected, $V_{IN} < V_{OUT}$)		80		μA
R_{ON}	Power FET "ON" Resistance			660		$\text{m}\Omega$
Battery Voltage Regulation Constant-Current Charge						
V_{FLOAT}	Regulated Output (Float) Voltage	$0^\circ\text{C} \leq T_A \leq 85^\circ\text{C}$	4.15	4.2	4.24	V
I_{OUT}	VOUT Pin Current	$R_{SET} = 10\text{k}$, Current Mode		90		mA
		$R_{SET} = 2\text{k}$, Current Mode		450		mA
		Standby Mode, $V_{OUT} = 4.2\text{V}$		-7		μA
		Shutdown Mode (R_{SET} Not Connected)		± 13		μA
		Sleep Mode, $V_{IN} = 0\text{V}$		± 0.2	± 2	μA
V_{ISET}	ISET Pin Voltage	$R_{SET} = 2\text{k}$, Current Mode	0.95	1	1.05	V
Trickle Charge						
I_{TRIKL}	Trickle Charge Current	$V_{OUT} < V_{TRIKL}$, $R_{SET} = 2\text{k}$		45		mA
V_{TRIKL}	Trickle Charge Threshold Voltage	$R_{SET} = 10\text{k}$, VOUT Rising		2.9		V
I_{TERM}	C/10 Termination Current Threshold	$R_{SET} = 2\text{k}$		45		mA
Battery Recharge Threshold						
ΔV_{RECHRG}	Recharge Battery Threshold Voltage	$V_{FLOAT} - V_{RECHRG}$		250		mV
TS Pin						
$V_{TS-COLD}$	TS Pin Threshold Voltage (Cold)	V_{TS} from Low to High		2.35		V
V_{TS-HOT}	TS Pin Threshold Voltage (Hot)	V_{TS} from High to Low		0.49		V
I_{TS}	Current Source			88.5		μA

Pin Functions

VIN (Pin 1, 2): Positive Input Supply Voltage. It Provides power to the charger VIN can range from 4.5V to 5.5V and should be bypassed with at least a 10 μ F capacitor.

CHRG1 (Pin 3): Open-Drain Charge Status Output. When the battery is charging, the CHRG1 pin is pulled low by an internal N-channel MOSFET. When the charge cycle is completed or reverse battery lockout / No AC is detected, CHRG1 is forced high impedance.

CHRG2 (Pin 4): Open-Drain Charge Status Output. When the battery is charging, the CHRG2 pin is pulled low by an internal N-channel MOSFET. When the charge cycle is completed or reverse battery lockout/No AC is detected, CHRG2 is forced high impedance.

The open-drain CHRG1 and CHRG2 outputs indicate various charger operations as shown in the following table. These status pins can be used to drive LEDs or communicate to the host processor. Note that OFF indicates the open-drain transistor is turned off.

Table 1: Status Pins Summary

CHARGE STATE	CHRG1	CHRG2
Battery Charging	ON	OFF
Charge Complete	OFF	ON
Sleep Mode	OFF	OFF

GND (Pin 5, 11): Ground.

ISET (Pin 6): Charge Current Set Pin. The charge current is programmed by connecting a 1% resistor, R_{SET} , to ground. When charging in constant-current mode, this pin serves to 1V. In all modes, the voltage on this pin can be used to measure the charge current using the following formula: $I_{OUT} = (V_{ISET}/R_{SET}) \cdot 900$. The ISET pin can also be used to shut down the charger. Disconnecting the program resistor from ground allows a weak current to pull the ISET pin high.

N/C (Pin 7, 9): No Connect.

TS (Pin 8): Temperature Sense. Connect a 10k Ω thermistor from the TS pin to ground. With the 88.5 μ A pull-up current source, the hot temperature voltage threshold is 490mV. For cold temperature, the voltage threshold is set at 2.35V with 88.5 μ A of pull-up current. The charge cycle begins or resumes once the temperature is within the acceptable range. When the TS pin is floating, the IC can also work.

VOUT (Pin 10): Charge Current Output. It should be bypassed with at least a 10 μ F capacitor. It provides charge current to the battery and regulates the final float voltage to 4.2V. An internal precision resistor divider from this pin sets the float voltage which is disconnected in shutdown mode.

Application Information

Operation

The HX6075 is a single-cell lithium-ion battery charger using a constant-current/constant-voltage algorithm. It can deliver up to 800mA of charge current (using a good thermal PC board layout) with a final float voltage accuracy of $\pm 1\%$. The HX6075 includes an internal P-channel power MOSFET and thermal regulation circuitry. No blocking diode or external current sense resistor is required and the HX6075 is capable of operating from a USB power source.

Normal Charge

Charging begins when the voltage at the VIN pin rises above 4.5V and a program resistor is connected from the ISET pin to ground. If the VOUT pin voltage is below 2.9V, the charger enters trickle charge mode. In this mode, the HX6075 supplies approximately 1/10 the programmed charge current to bring the battery voltage up to a safe level for full current charging.

When the VOUT pin voltage rises above 2.9V, the charger enters constant-current mode, where the programmed charge current is supplied to the battery. When the VOUT pin approaches the final float voltage (4.2V), the HX6075 enters constant-voltage mode, and the charge current begins to decrease.

Battery Temperature Monitoring

A negative temperature coefficient (NTC) thermistor located close to the battery pack can be used to monitor battery temperature and will not allow charging unless the battery temperature is within an acceptable range.

Connect a 10k Ω thermistor from the TS pin to ground. With the 88.5 μ A pull-up current source, the Hot temperature voltage threshold is 490mV. For Cold temperature, the voltage threshold is set at 2.35V with 88.5 μ A of pull-up current. The charge cycle begins or resumes once the temperature is within the acceptable range.

VIN Bypass Capacitor

Many types of capacitors can be used for input bypassing; however, caution must be exercised when using multilayer ceramic capacitors. Because of the self resonant and high Q characteristics of some types of ceramic capacitors, high voltage transients can be generated under some start-up conditions, such as connecting the charger input to a live power source. Adding a 1.5W resistor in series with an X5R ceramic capacitor will minimize start-up voltage transients.

Packaging Information

DFN3*3-10L Package Outline Dimension

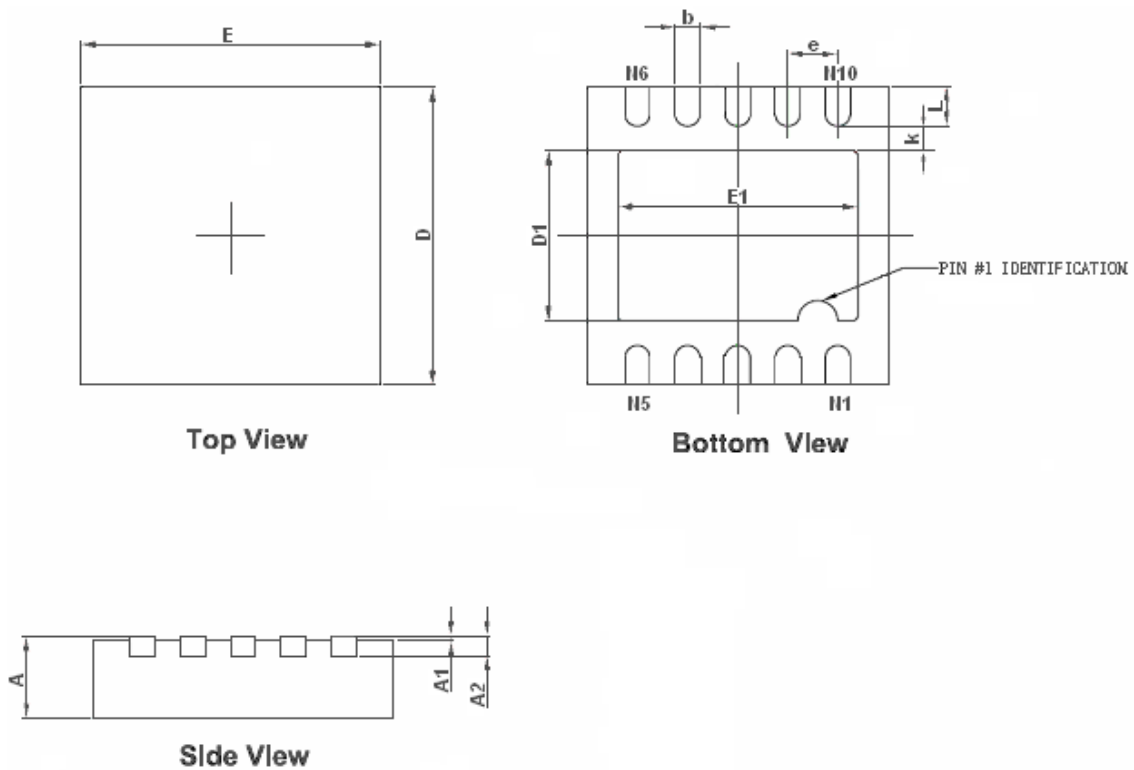

Symbol	Dimensions In Millimeters		Dimensions In Inches	
	Min	Max	Min	Max
A	0.700/0.800	0.800/0.900	0.028/0.031	0.031/0.035
A1	0.000	0.050	0.000	0.002
A2	0.153	0.253	0.006	0.010
D	2.900	3.100	0.114	0.122
E	2.900	3.100	0.114	0.122
D1	1.600	1.800	0.063	0.071
E1	2.300	2.500	0.091	0.098
k	0.200MIN		0.008MIN	
b	0.200	0.300	0.008	0.012
e	0.500TYP		0.020TYP	
L	0.300	0.500	0.012	0.020

Subject changes without notice.