

### Features

- Input Supply Range: 4.7V ~ 6V
- High Efficiency Current Mode PWM Controller
- End - Charge - Current Detection Output
- Constant Switching Frequency for Minimum Noise
- ±1% Charge Voltage Accuracy
- Automatic Battery Recharge
- Automatic Shutdown When Input Supply is Removed
- Automatic Trickle Charging of Low Voltage Batteries
- Battery Temperature Sensing
- Stable with Ceramic Output Capacitor
- 8-Lead SOP Package

### Description

The HX6202B is a complete battery charger controller for one (4.22V) cell lithium-ion battery. The HX6202B provides a small, simple and efficient solution to fast charge Li-ion battery. An external sense resistor sets the charge current with high accuracy. An internal resistor divider and precision reference set the final float voltage to 4.22V per cell with ±1% accuracy.

When the input supply is removed, the HX6202B automatically enters a low current sleep mode, dropping the battery drain current to 4µA. After the charge cycle ends, if the battery voltage drops below 4.05V per cell, a new charge cycle will automatically begin.

The HX6202B is available in the 8-lead SOP Package.

### Application

- Charging Docks
- Handheld Instruments
- Portable Computers

### Typical Application Circuit

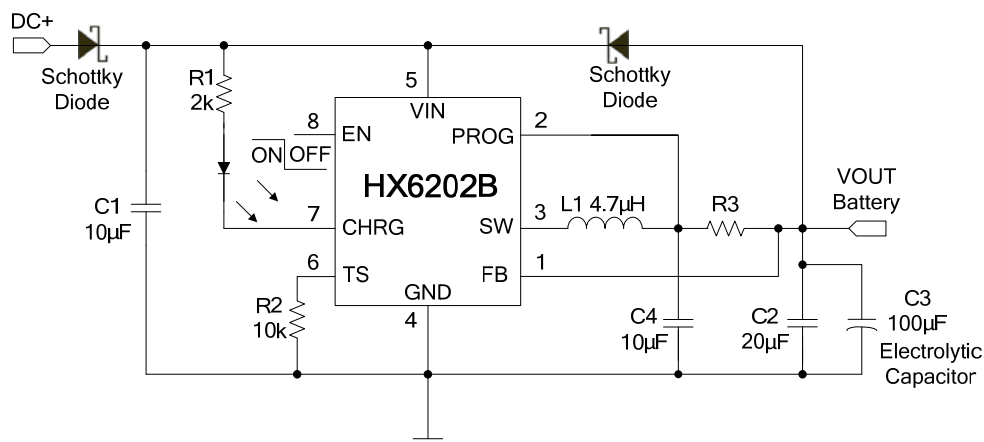

\*The charge current can be set by  $I_{BAT} = 0.17V/R3$ .

\*This application circuit is MID.

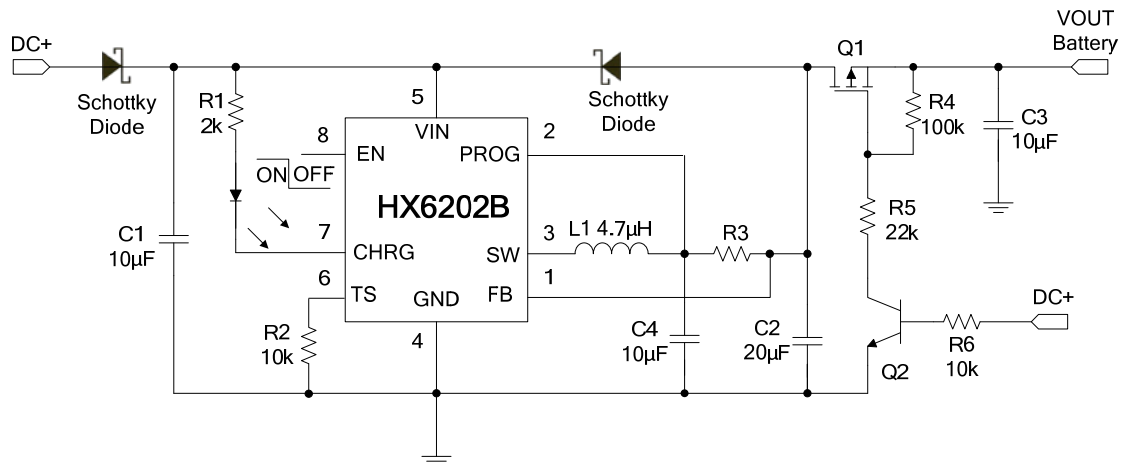

\*This application circuit is for backup source specially.

## Pin Assignment and Description

TOP VIEW		PIN	NAME	DESCRIPTION
		1	FB	Feedback
		2	PROG	Charge Current Program
		3	SW	Switch Output
		4	GND	Ground
		5	VIN	Input
		6	TS	Temperature Sense
		7	CHRG	Open-Drain Charge Status for Output
		8	EN	ON/OFF Control(High Enable)

## Absolute Maximum Ratings (Note 1)

- VIN, CHRG, SW, PROG Voltage..... -0.3V ~ 6.5V
- SW Pin Current ..... 3.8A
- Operating Temperature Range (Note 2)..... -40°C ~ +85°C
- Maximum Junction Temperature ..... +150°C
- Storage Temperature Range ..... -65°C ~ +125°C
- Lead Temperature (Soldering, 10 sec)..... +265°C

**Note 1:** Stresses listed as the above “Absolute Maximum Ratings” may cause permanent damage to the device. Exposure to absolute maximum rating conditions for extended periods may remain possibility to affect device reliability.

**Note 2:** The HX6202B is guaranteed to meet performance specifications from 0°C to 70°C. Specifications over the -40°C to 85°C operating temperature range are assured by design, characterization and correlation with statistical process controls.

## Electrical Characteristics

Operating Conditions:  $T_A=25^{\circ}\text{C}$ ,  $V_{IN}=5\text{V}$ , unless otherwise specified.

SYMBOL	PARAMETER	CONDITIONS	MIN	TYP	MAX	UNITS
$V_{IN}$	Input Supply Voltage		4.7	5.0	6.0	V
$I_Q$	Input Supply Current	Shutdown Mode		19		$\mu\text{A}$
		Sleep Mode		4		$\mu\text{A}$
$V_{ASD}$	Automatic Shutdown Threshold Voltage	$V_{IN} - V_{FLOAT}$		150		mV
$f_{OSC}$	Switching Frequency	$I_{BAT} = 1\text{A}$		1		MHz
DC	Maximum Duty Cycle				100	%
<b>Battery Voltage Regulation Constant-Current Charge</b>						
$V_{FLOAT}$	Battery Regulated Float Voltage	$0^{\circ}\text{C} \leq T_A \leq 85^{\circ}\text{C}$ , $I_{OUT} = 1.2\text{A}$	4.17	4.22	4.23	V
$V_{SNS(CHG)}$	Constant Current Sense Voltage	$3\text{V} \leq V_{BAT} \leq 4\text{V}$		170		mV
<b>Trickle Charge</b>						
$V_{SNS(TRLK)}$	Trickle Current Sense Voltage	$V_{BAT} = 0\text{V}$		10		mV
$V_{TRIKL}$	Trickle Charge Threshold Voltage	$V_{BAT}$ Rising		2.9		V
<b>Battery Recharge Threshold</b>						
$\Delta V_{RECHRG}$	Recharge Battery Voltage Offset from Full Charged Battery Voltage	$V_{FLOAT} - V_{RECHRG}$ , $V_{BAT}$ Falling		170		mV
<b>TS Pin</b>						
$V_{TS-HOT}$	TS Pin Threshold Voltage (Hot)	$V_{TS}$ Falling Hysteresis		0.54		V
$V_{TS-COLD}$	TS Pin Threshold Voltage (Cold)	$V_{TS}$ Rising Hysteresis		2.36		V
$I_{TS}$	TS Pin Output Current	$V_{TS} = 0.85\text{V}$		82		$\mu\text{A}$

## Typical Performance Characteristics

Operating Conditions: TA = 25°C, R3 = 0.33||0.33Ω, unless otherwise specified.

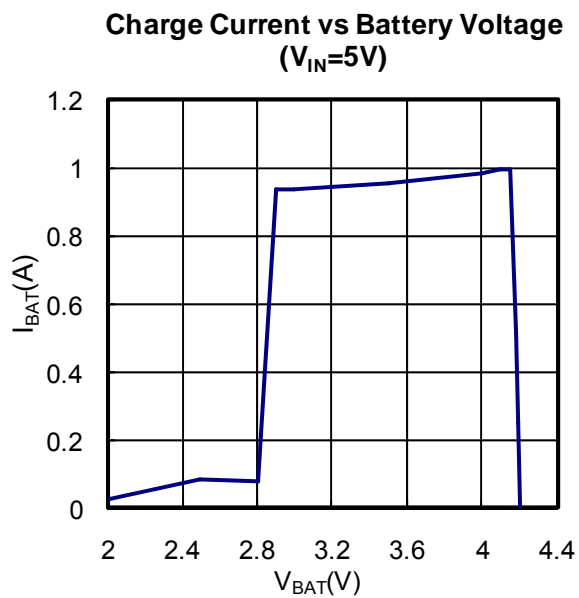
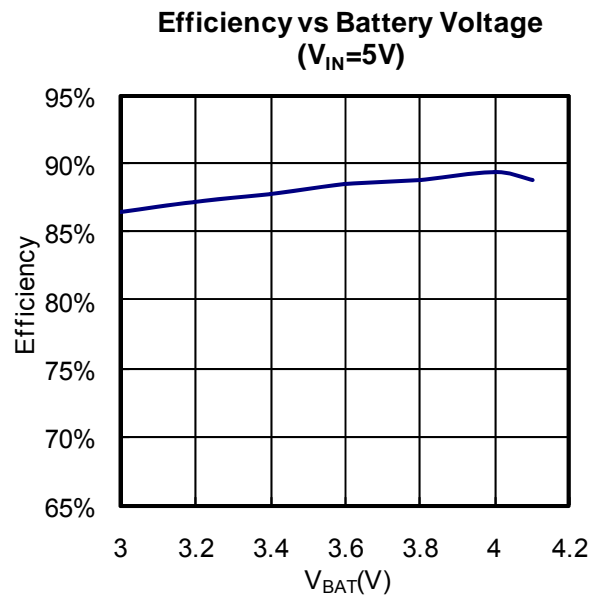
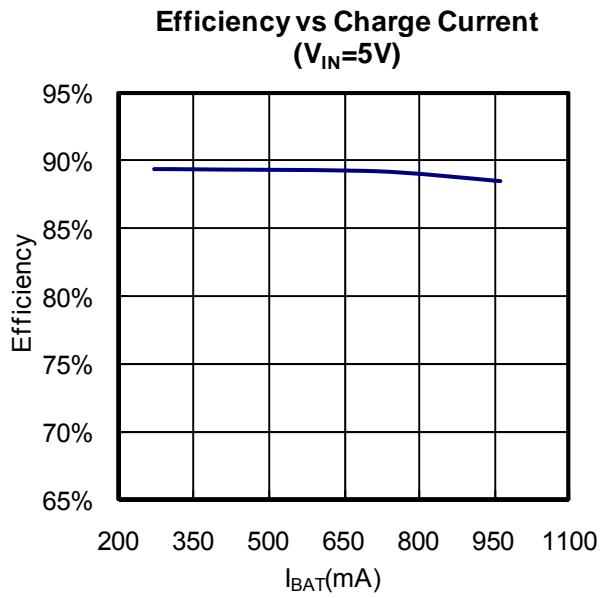

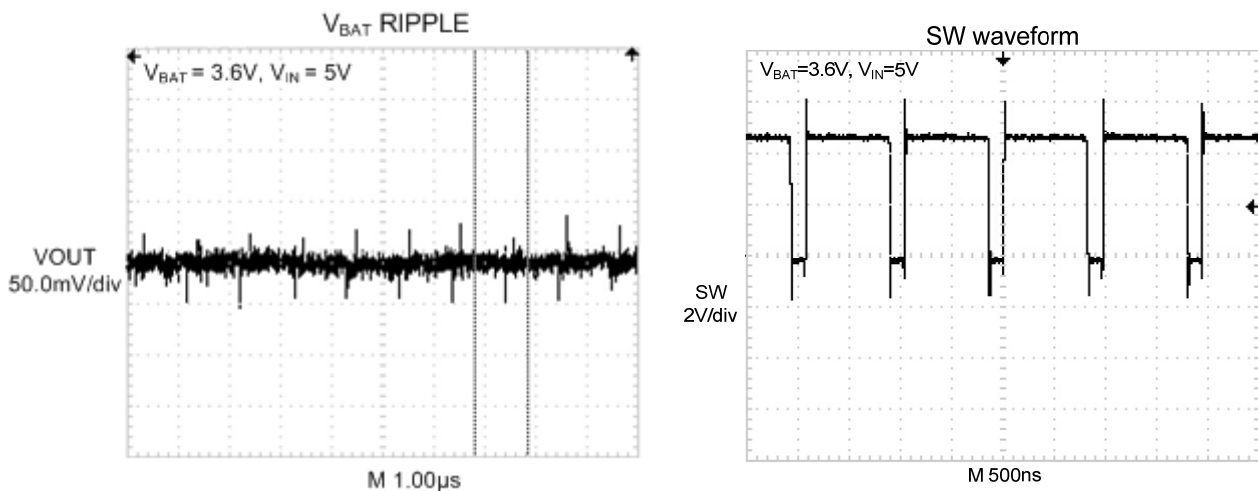

## Pin Functions

**FB (Pin 1):** Feedback Pin. Receive the feedback voltage from an external resistor across the output.

**PROG (Pin 2):** Charge Current Program. The output current is set by an external resistor according to the following formula:  $I_{BAT} = 0.17V/R3$ .

**SW (Pin 3):** Charge Current Output. It provides charge current to the battery and regulates the final float voltage to 4.22V.

**GND (Pin 4):** IC Ground.

**VIN (Pin 5):** Positive Supply Voltage Input. VIN can range from 4.7V to 6V. A 10µF low ESR capacitor is required at the source pins of the power P-channel MOSFET.

**TS (Pin 6):** TS Thermistor Input. With an external 10kΩ negative temperature coefficient thermistor to ground, this pin senses the temperature of the battery pack and stops the charger when the temperature is out of range. When the voltage at this pin drops below 540mV at hot temperature or rises above 2.36V at cold temperature, charging is suspended and the internal timer stops. The CHRG pin output is not affected during this hold state. To disable the temperature qualification function, ground the TS pin.

**CHRG (Pin 7):** When the charge current drops below the End-of-Charge threshold for more than 120µs, the N-channel MOSFET turns off and a weak current source is connected from the CHRG pin to GND. When the input supply is removed, the weak current source is turned off and the CHRG pin becomes high impedance.

**EN (Pin 8):** ON/OFF Control (High Enable). EN = High: Normal free running operation; EN = Low: Shutdown.

## Block Diagram

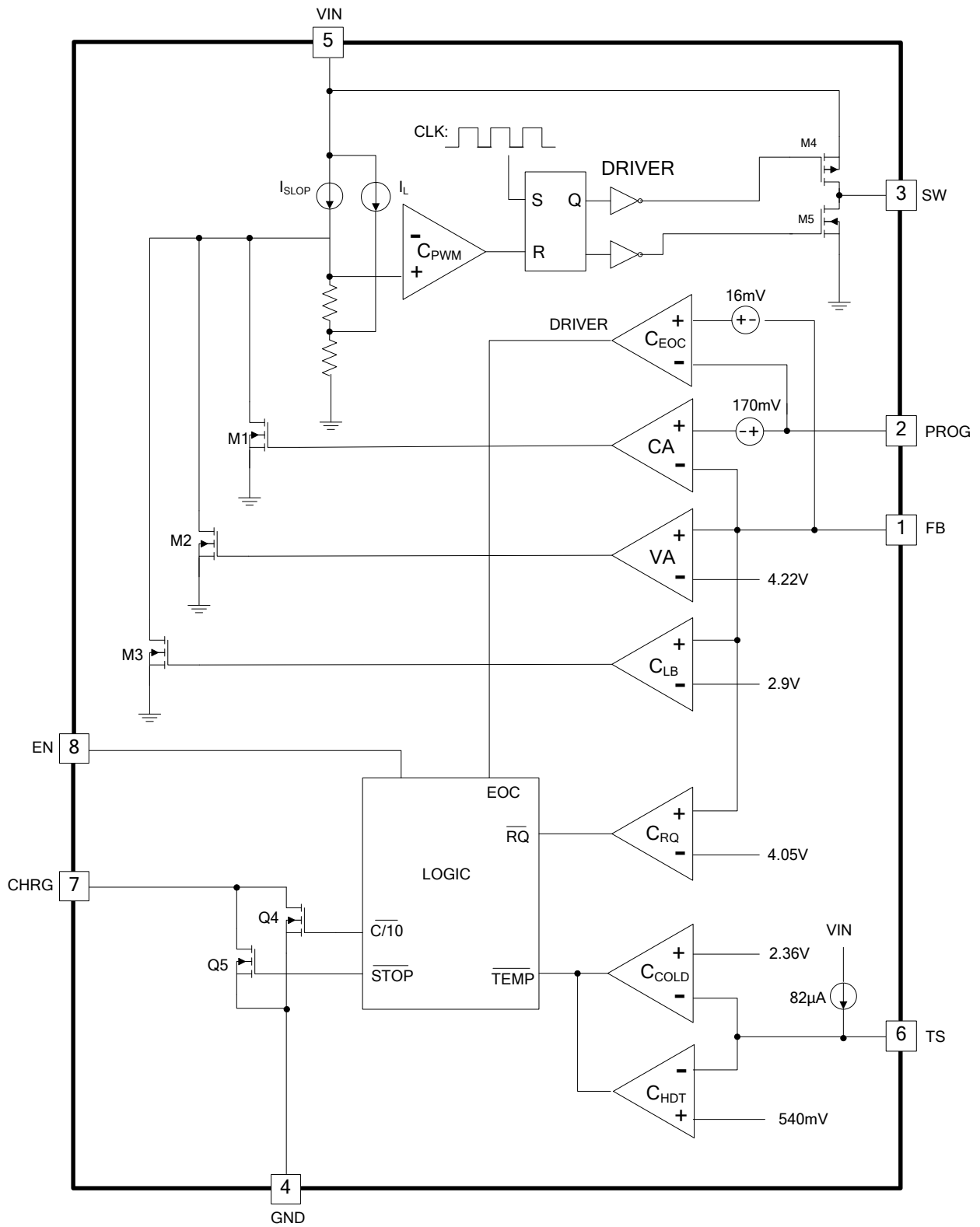

# Application Information

## Functional Description

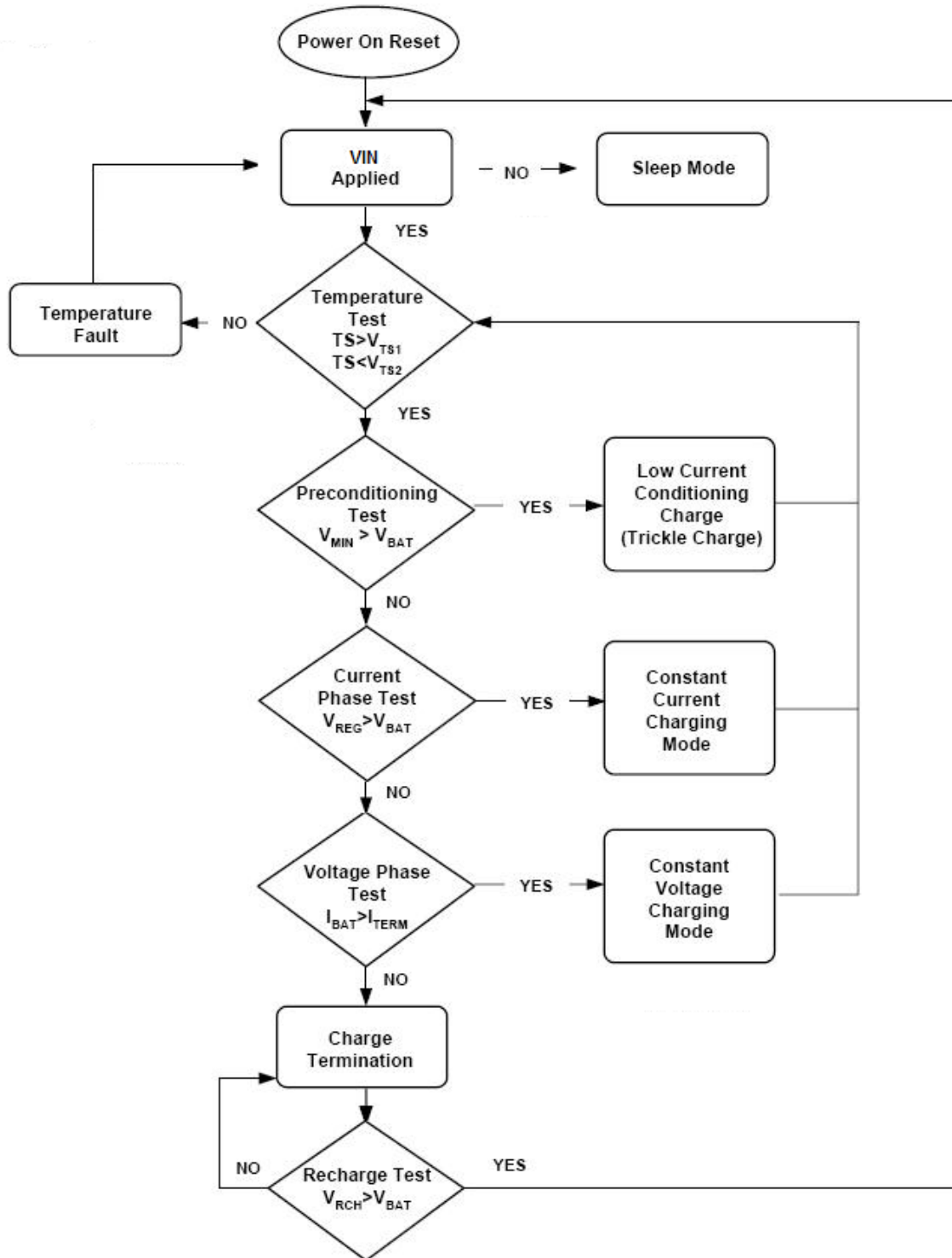

Figure 1: Operation Flow Chart

## Operation

The HX6202B is a constant current, constant voltage Li-Ion battery charger controller that uses a current mode PWM step-down (buck) switching architecture. The charge current is set by an external sense resistor (R3) across the PROG and FB pins. The final battery float voltage is internally set to 4.22V. For batteries like lithium-ion that require accurate final float voltage, the internal reference, voltage amplifier and the resistor divider provide regulation with high accuracy.

At the beginning of the charge cycle, if the battery voltage is less than the trickle charge threshold, the charger goes into trickle charge mode. The trickle charge current is internally set to 8% of the full-scale current.

When the battery voltage exceeds the trickle charge threshold, the charger goes into the full-scale constant current charge mode. In constant current mode, the charge current is set by the external sense resistor R3 and an internal 170mV reference:  $I_{BAT} = 0.17V/R3$ .

When the battery voltage approaches the programmed float voltage, the charge current will start to decrease. When the current drops to 8% of the full-scale charge current, an internal comparator turns off the internal pull-down N-channel MOSFET at the CHRG pin, and connects a weak current source to ground to indicate a end-of-charge condition and then the charge cycle is terminated and the CHRG pin is forced high impedance.

To restart the charge cycle, remove and reapply the input voltage or momentarily shut the charger down. Also, a new charge cycle will begin if the battery voltage drops below the recharge threshold voltage.

When the input voltage is present, the charger can be shut down. When the input voltage is not present, the charger goes into sleep mode. This will greatly reduce the current drain on the battery and increase the standby time.

A 10kΩ TS (negative temperature coefficient) thermistor can be connected from the TS pin to ground for battery temperature qualification.

## Qualification and Precharge

The HX6202B suspends charge if the battery temperature is outside the  $V_{TS1}$  to  $V_{TS2}$  range and suspends charge until the battery temperature is within the allowed range. The HX6202B also checks the battery voltage. If the battery voltage is below the precharge threshold  $V_{(MIN)}$ , the HX6202B uses precharge to condition the battery. The conditioning charge rate  $I_{(PRECHG)}$  is set at approximately 8% of the regulation current. See Figure 2 for a typical charge-profile.

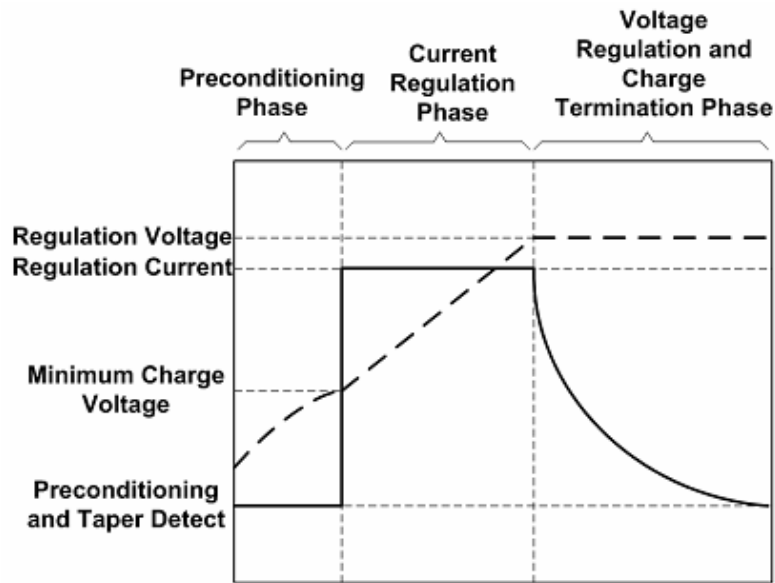

Figure 2: Typical Charge Profile

### Charge Termination Recharge

The HX6202B monitors the charging current during the voltage-regulation phase. The HX6202B declares a done condition and terminates charge when the current drops to the charge termination threshold. A new charge cycle begins when the battery voltage falls below 4.05V.

### Battery Temperature Monitoring

A negative temperature coefficient (NTC) thermistor located close to the battery pack can be used to monitor battery temperature and will not allow charging unless the battery temperature is within an acceptable range.

Connect a 10kΩ thermistor from the TS pin to ground. With the 82μA pull-up current source, the Hot temperature voltage threshold is 540mV. For Cold temperature, the voltage threshold is set at 2.36V with 82μA of pull-up current. The charge cycle begins or resumes once the temperature is within the acceptable range.

### Charge Status Indication

The HX6202B reports the status of the charge on the CHRG pin. The following Table 1 summarized the operation of the CHRG pin. The CHRG pin can be used to drive a chip LED.

Table 1: Pin status summary

CONDITION	CHRG PIN
Battery conditioning and charging	Low
Charge complete(done)	Hi-Z
Temperature fault or sleep mode	Hi-Z

### Trickle Charge

At the beginning of a charge cycle, if the battery voltage is below the trickle charge threshold, the charger goes into trickle charge mode with the charge current reduced to 8% of the full-scale current.

### Shutdown

The HX6202B can be shut down by pulling the EN pin to ground. In shutdown, the output of the CHRG pin is high impedance and the quiescent current remains at 19 $\mu$ A.

### Input and Output Capacitors

Since the input capacitor is assumed to absorb all input switching ripple current in the converter, it must have an adequate ripple current rating. Worst-case RMS ripple current is approximately one-half of output charge current. Actual capacitance value is not critical. Solid tantalum capacitors have a high ripple current rating in a relatively small surface mount package, but caution must be used when tantalum capacitors are used for input bypass. High input surge currents can be created when the adapter is hot-plugged to the charger and solid tantalum capacitors have a known failure mechanism when subjected to very high turn-on surge currents. Selecting the highest possible voltage rating on the capacitor will minimize problems. Consult with the manufacturer before use. The selection of output capacitor  $C_{OUT}$  is primarily determined by the ESR required to minimize ripple voltage and load step transients. The output ripple  $\Delta V_{OUT}$  is approximately bounded by:

$$\Delta V_{OUT} \leq \Delta I_L \left( ESR + \frac{1}{8f_{OSC}C_{OUT}} \right)$$

Since  $\Delta I_L$  increases with input voltage, the output ripple is highest at maximum input voltage. Typically, once the ESR requirement is satisfied, the capacitance is adequate for filtering and has the necessary RMS current rating. Switching ripple current splits between the battery and the output capacitor depending on the ESR of the output capacitor and the battery impedance. EMI considerations usually make it desirable to minimize ripple current in the battery leads.

## Packaging Information

### SOP-8L Package Outline Dimension

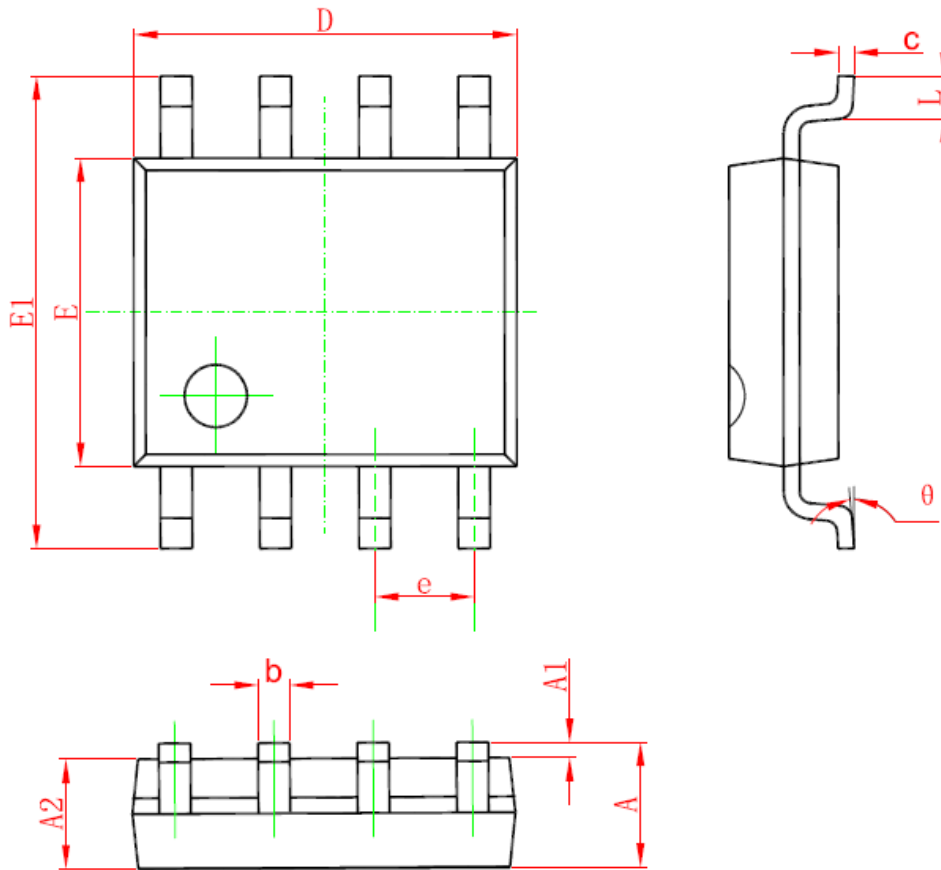

Symbol	Dimensions In Millimeters		Dimensions In Inches	
	Min	Max	Min	Max
A	1.350	1.750	0.053	0.069
A1	0.100	0.250	0.004	0.010
A2	1.350	1.550	0.053	0.061
b	0.330	0.510	0.013	0.020
c	0.170	0.250	0.006	0.010
D	4.700	5.100	0.185	0.200
E	3.800	4.000	0.150	0.157
E1	5.800	6.200	0.228	0.244
e	1.270(BSC)		0.050(BSC)	
L	0.400	1.270	0.016	0.050
θ	0°	8°	0°	8°

Subject changes without notice.