

### Features

- 200mΩ Typ. High-Side MOSFET
- 0.8A Current Limit ( $V_{IN}=3.0V$ )
- Small SOT-23-5L Package Minimizes Board Space
- Thermal Protection
- Low Quiescent Current: 50μA
- Wide Input Voltage Range: 1.8V ~ 5.5V

### Applications

- Battery-Powered Equipment
- Motherboard USB Power Switch
- USB Device Power Switch
- Hot-Plug Power Supplies
- Battery-Charger Circuits

### Description

The HX9004 is an integrated 200mΩ power switch for self-powered and bus-powered Universal Serial Bus (USB) applications. Its low quiescent supply current (50μA) and small package (SOT-23-5L) is particularly suitable in battery-powered portable equipment.

Several protection functions include soft start to limit inrush current during plug-in, current limiting at 0.8A ( $V_{IN}=3.0V$ ), and thermal shutdown to protect damage under over current conditions.

### Typical Application Circuit

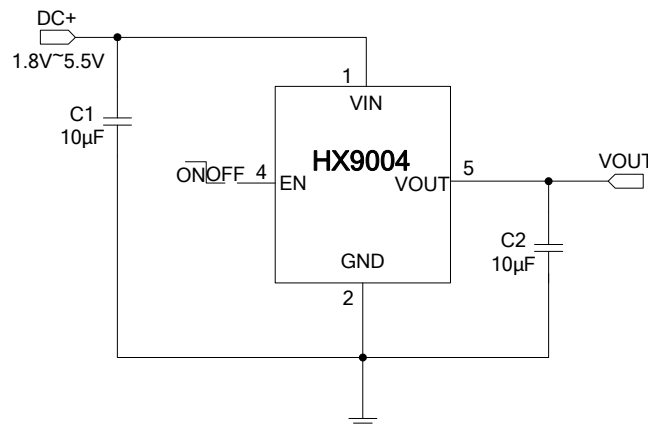

## Pin Assignment

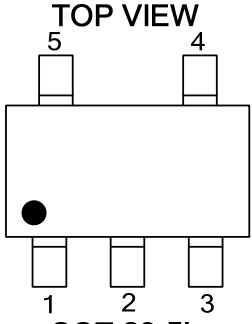
 <p>TOP VIEW</p> <p>SOT-23-5L</p>	PIN NUMBER	PIN NAME	FUNCTION
	1	VIN	Power Input
	2	GND	Ground
	3	NC	No Used
	4	EN	ON/OFF Control (High Enable)
	5	VOUT	Output Pin

## Absolute Maximum Ratings (Note 1)

- Supply Voltage .....7V
- Chip Enable.....-0.3V ~ 7V
- Power Dissipation, Pd @ TA = 25°C .....SOT-23-5L 0.25W
- Operating Temperature Range(Note 2).....-40°C ~ +85°C
- Storage Temperature.....-65°C ~ +150°C
- Junction Temperature .....-40°C ~ +125°C
- Lead Temperature.....+265°C

**Note 1:** Stresses listed as the above “Absolute Maximum Ratings” may cause permanent damage to the device.

Exposure to absolute maximum rating conditions for extended periods may remain possibility to affect device reliability.

**Note 2:** The HX9004 is guaranteed to meet performance specifications from 0°C to 85°C. Specifications over the -40°C to 85°C operating temperature range are assured by design, characterization and correlation with statistical process controls.

## Electrical Characteristics

Operating Conditions:  $T_A = 25^\circ\text{C}$ ,  $V_{IN} = 5\text{V}$ ,  $C_{IN} = C_{OUT} = 10\mu\text{F}$ , unless otherwise specified.

SYMBOL	PARAMETER	CONDITIONS	MIN	TYP	MAX	UNITS
$V_{IN}$	Input Voltage Range		1.8		5.5	V
$R_{DS(ON)}$	Output NMOFET $R_{DS(ON)}$	$V_{IN}=5.0\text{V}, I_{LOAD}=500\text{mA}$	100	200	250	$\text{m}\Omega$
		$V_{IN}=2.5\text{V}, I_{LOAD}=300\text{mA}$	150	280	350	$\text{m}\Omega$
		$V_{IN}=1.8\text{V}, I_{LOAD}=300\text{mA}$	750	1100	1350	$\text{m}\Omega$
$I_Q$	Supply Current	$V_{IN}=3.0\text{V}$		50		$\mu\text{A}$
		$V_{IN}=5.0\text{V}$	40	80	160	$\mu\text{A}$
$I_{LIMIT}$	Current Limit Threshold	$V_{IN}=3.0\text{V}$	700	800	950	mA
$V_{ENH}$	EN Input High Threshold		1.5			V
$V_{ENL}$	EN Input Low Threshold				0.6	V
$I_{OFF}$	Shutdown Supply Current	$V_{EN} = 0\text{V}$		0.5	1	$\mu\text{A}$
$V_{UVLO}$	VIN Under Voltage Lockout	$I_{OUT}=300\text{mA}$ , $V_{IN}: 2.4\text{V}\rightarrow 0\text{V}$	1.4	1.65	1.8	V
$\Delta V_{UVLO}$	VIN Under Voltage Hysteresis			150		mV
$T_{SD}$	Thermal Limit			130		$^\circ\text{C}$
$\Delta T_{SD}$	Thermal Limit Hysteresis			20		$^\circ\text{C}$

## Typical Operating Characteristics

Operating Conditions:  $T_A=25^{\circ}\text{C}$ , unless otherwise specified.

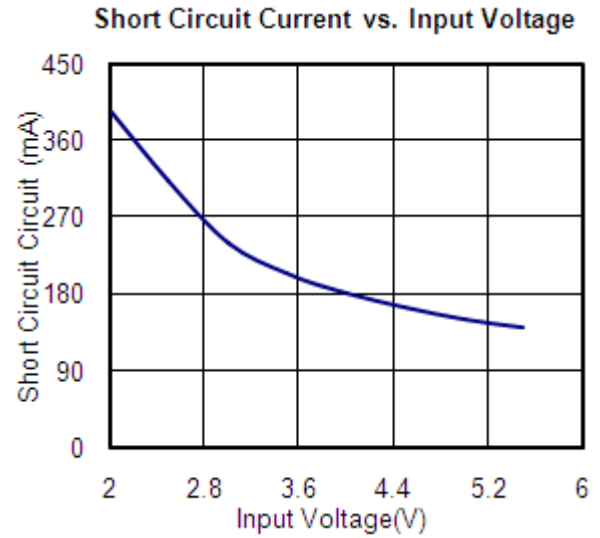
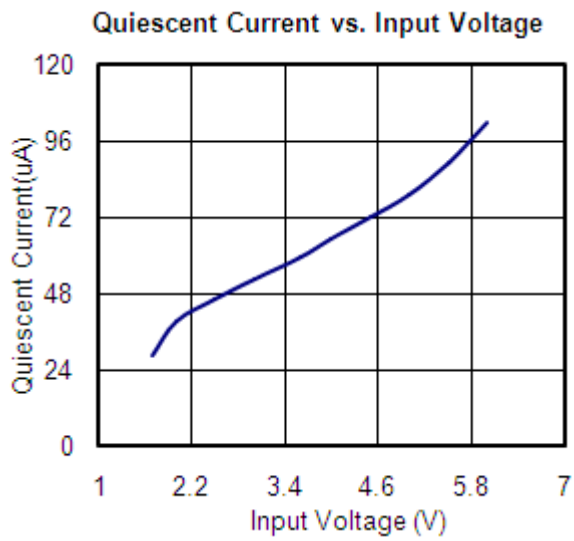
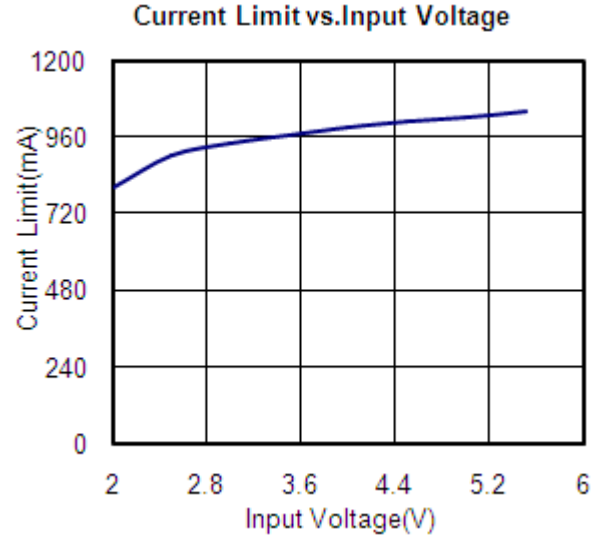
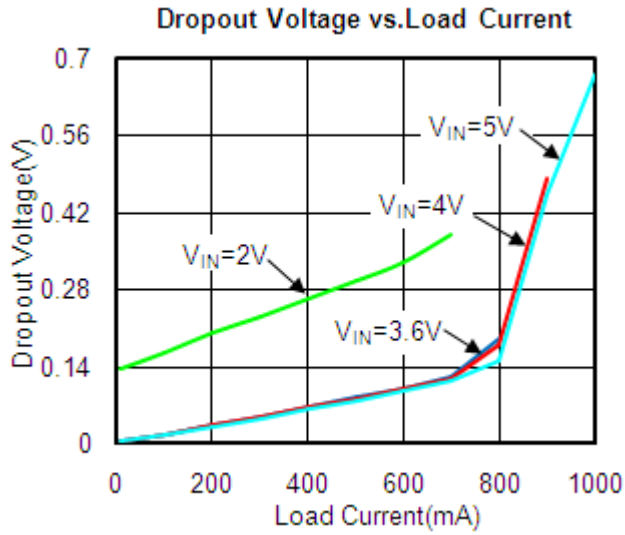

**Output Voltage vs. Output Current**

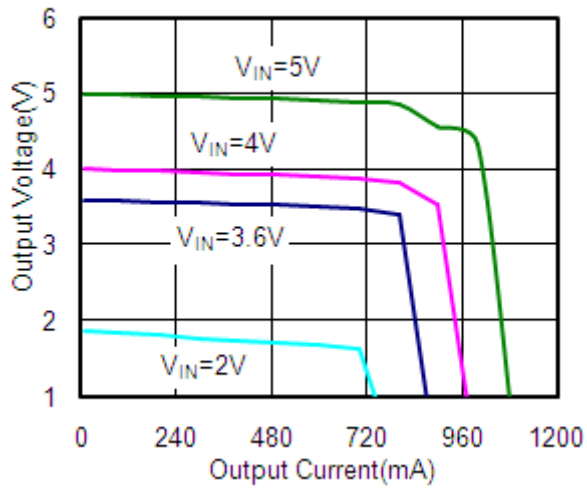

**Resistace  
( $I_{OUT}=100mA$ )**

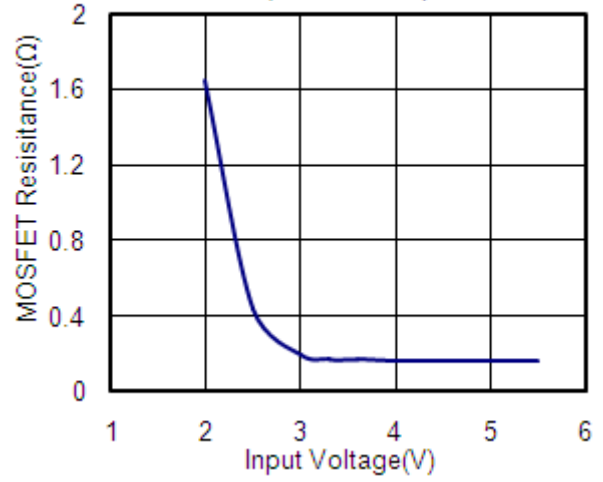

**EN Turn-On Response**

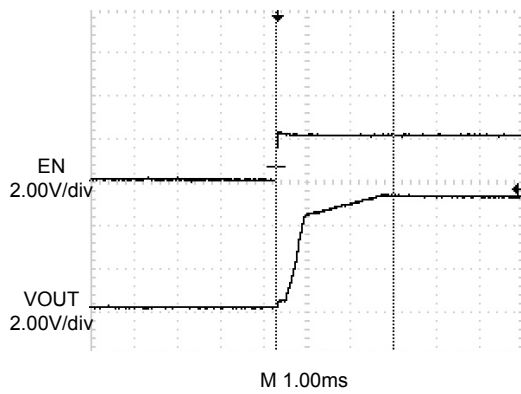

**EN Turn-Off Response**

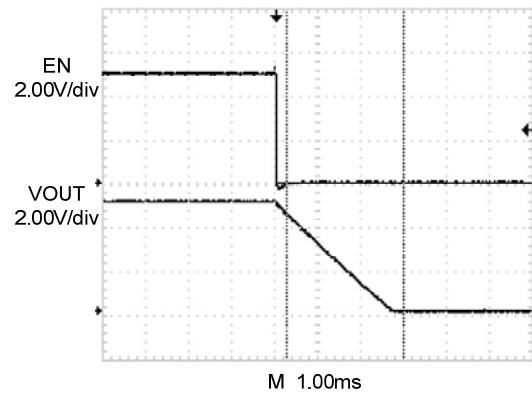



---

## Application Information

The HX9004 is a high-side single switch with active-high enable input.

### Input and Output

V<sub>IN</sub> (input) is the power supply connection to the circuitry and the drain of the output MOSFET. V<sub>OUT</sub> (output) is the source of the output MOSFET. In a typical circuit, current flows through the switch from V<sub>IN</sub> to V<sub>OUT</sub> toward the load. Both V<sub>OUT</sub> pins must be short on the board and connected to the load and so do both V<sub>IN</sub> pins but connected to the power source.

### Thermal Shutdown

Thermal shutdown shuts off the output MOSFET if the die temperature exceeds 130°C and 20°C of hysteresis forces the switch turning off until the die temperature drops to 110°C.

### Under-voltage Lockout

UVLO prevents the MOSFET switch from turning on until input voltage exceeds 1.65V (typical). If input voltage drops below 1.65V (typical), UVLO shuts off the MOSFET switch.

### Current Limiting and Short Protection

The current limit circuit is designed to protect the system supply, the MOSFET switch and the load from damage caused by excessive currents. The current limit threshold is set internally to limit the output current to approximately 0.8A typical (V<sub>IN</sub>=3.0V). When a heavy load or short circuit is applied to an enabled switch, a large transient current may flow until the current limit circuitry responds. Once this current limit threshold is exceeded the device enters constant current mode until the thermal shutdown occurs or the fault is removed.

### Filtering

To limit the input voltage drop during hot-plug events connect a 10μF ceramic capacitor from V<sub>IN</sub> to GND. However, higher capacitor values will further reduce the voltage drop at the input.

Connect a sufficient capacitor from V<sub>OUT</sub> to GND. This capacitor helps to prevent inductive parasitics from pulling V<sub>OUT</sub> negative during turn-off or EMI damage to other components during the hot detachment. It is also necessary for meeting the USB specification during hot plug-in operation. If HX9004 is implanted in device end application, minimum 10μF capacitor from V<sub>OUT</sub> to GND is recommended and higher capacitor values are also preferred.

In choosing these capacitors, special attention must be paid to the Effective Series Resistance, ESR, of the capacitors to minimize the IR drop across the capacitor's ESR. A lower ESR on this capacitor can get a lower IR drop during the operation.

Ferrite beads in series with all power and ground lines are recommended to eliminate or significantly reduce EMI. In selecting a ferrite bead, the DC resistance of the wire used must be kept to a minimum to reduce the voltage drop.

### **Layout and Thermal Dissipation**

1. Place the switch as close to the USB connector as possible. Keep all traces as short as possible to reduce the effect of undesirable parasitic Inductance.
2. Place the output capacitor and ferrite beads as close to the USB connector as possible. If ferrite beads are used, use wires with minimum resistance and large solder pads to minimize connection resistance.
3. Under normal operating conditions, the package can dissipate the channel heat away. Wide power bus planes connected to VIN and VOUT and a ground plane in contact with the device will help dissipate additional heat.

## Package Information

### SOT-23-5L Package Outline Dimension

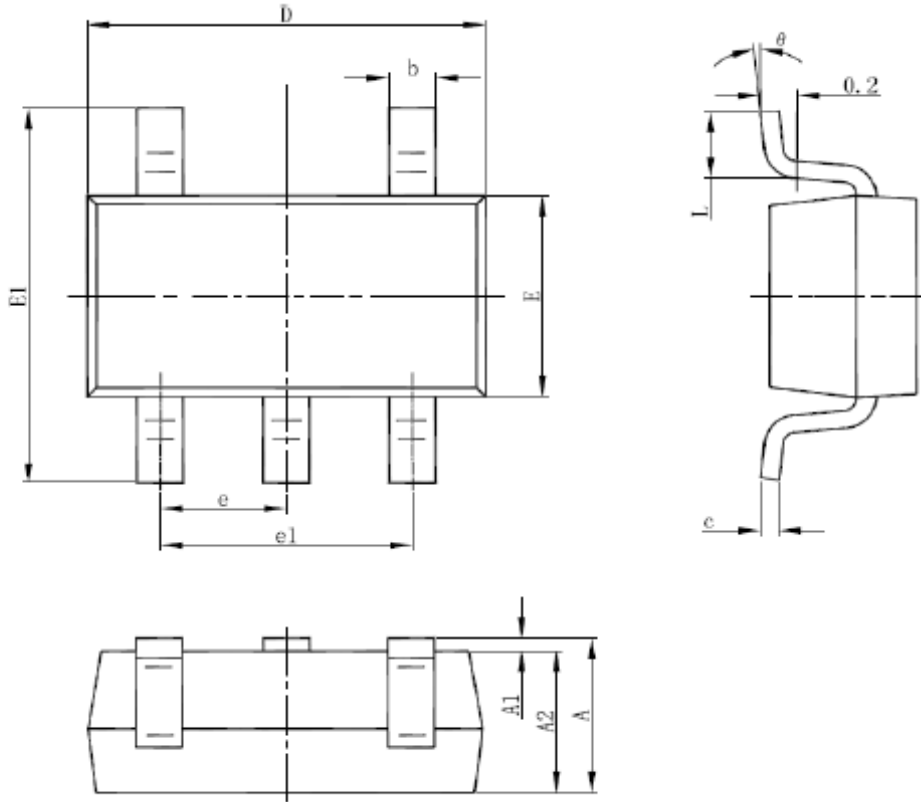

Symbol	Dimensions In Millimeters		Dimensions In Inches	
	Min	Max	Min	Max
A	1.050	1.250	0.041	0.049
A1	0.000	0.100	0.000	0.004
A2	1.050	1.150	0.041	0.045
b	0.300	0.500	0.012	0.020
c	0.100	0.200	0.004	0.008
D	2.820	3.020	0.111	0.119
E	1.500	1.700	0.059	0.067
E1	2.650	2.950	0.104	0.116
e	0.950(BSC)		0.037(BSC)	
e1	1.800	2.000	0.071	0.079
L	0.300	0.600	0.012	0.024
$\theta$	0°	8°	0°	8°

Subject changes without notice