



Ultra-Small Package PWM/PFM Switching Control Step-Up Switching Regulator

General Description

The ME2179 series is a CMOS step-up switching regulator which mainly consists of a reference voltage source, an oscillation circuit, an error amplifier, a phase compensation circuit, a timer latch short-circuit protection circuit, a PWM / PFM switching control circuit. With an external low-ON-resistance Nch Power MOS, this product is ideal for applications requiring high efficiency and a high output current.

During light-load, ME2179 Series switches its operation to the PFM control by the PWM / PFM switching control circuit in order to prevent efficiency decline due to the IC operating current. Ceramic capacitors can be used for output capacitor.

Typical Application

- MP3 players, digital audio players
- Digital cameras, GPS, wireless transceiver
- Portable devices

Features

- Input voltage range: 1.8 V to 5.5 V
- Duty ratio: Built-in PWM/PFM switching control circuit 28% to 85%
- oscillator frequency : 1.2MHz
- Reference voltage : 0.6 x (1±2%) V
- Maximum output current: 2.0A typ.
(VDD=3V, Vout=5.0V)
- Soft start function: 8ms typ.
- Low current consumption: 70µA typ. at switching off
- Shutdown function: Current consumption 1.0µA max. at shutdown
- External parts: Inductor, diode, capacitor, transistor
- Timer latch short-circuit protection circuit: Selectable with / without short-circuit protection circuit for each product;
- Settable delay time by external capacitor (in the product with short-circuit protection)
- UVLO (under-voltage lockout) function: Selectable with UVLO for each product

Package

- 6-pin SOT23-6

Typical Application Circuit

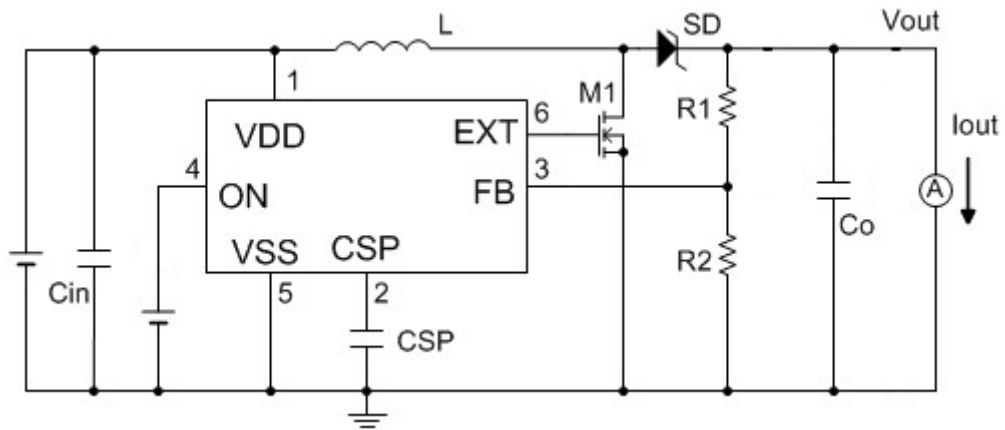

Selection Guide

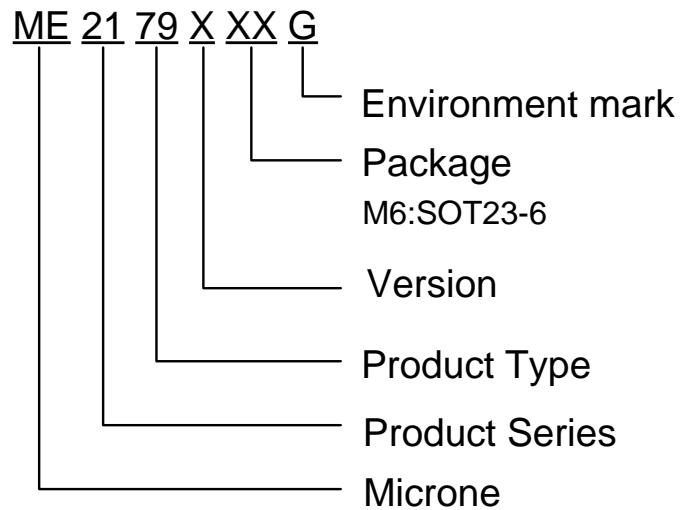

product series	product description
ME2179AM6G	Package: SOT23-6

NOTE: If you need other voltage and package, please contact our sales staff.

Pin Configuration & Pin Assignment

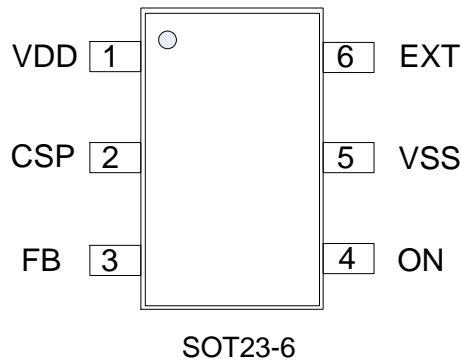

Pin Assignment

Pin Number	Pin Name	Function
1	VDD	IC power supply pin
2	CSP	Delay time setting pin for short-circuit protection
3	FB	Feed Back voltage pin
4	ON	Power-off pin “H” : Power-on (normal operation) “L” : Power-off (standby)
5	VSS	GND pin
6	EXT	External transistor connection pin

Block Diagram

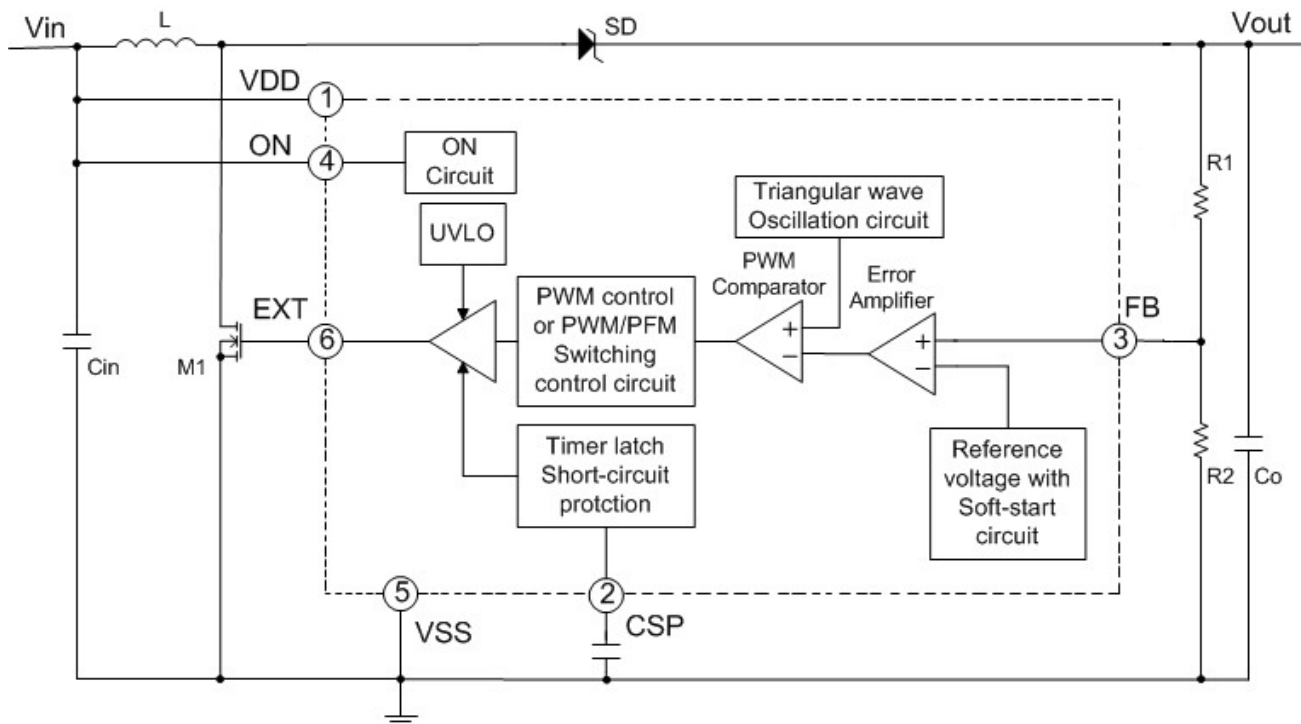

Absolute Maximum Ratings

Parameter	Symbol	Rating	Unit
VDD Pin Voltage	VDD	-0.3~6.0	V
EXT Pin Voltage	V _{EXT}	-0.3~VDD+0.3	V
FB Pin Voltage	V _{FB}	-0.3~VDD+0.3	V
ON Pin Voltage	V _{ON}	-0.3~VDD+0.3	V
Power Dissipation (SOT23-6)	Pd	300	mW
Operating Temperature Range	T _{Opr}	-40~+85	°C
Storage Temperature Range	T _{stg}	-40~+125	°C

Electrical Characteristics

Measuring conditions: VDD= 3.3V, ON=VDD, Vout=5.0V, Ta=25°C. Unless otherwise specified.

Parameter	Symbol	Condition	Min	Typ.	Max	Unit
Feedback voltage	V _{FB}	-	0.588	0.6	0.612	V
FB pin input current	I _{FB}	VDD= 1.8 V to 5.5 V, FB pin	-0.1	-	+0.1	μA
Input voltage	VDD	-	1.8	-	5.5	V
Current consumption 1	I _{SS1}	At switching operation, no load V _{FB} =V _{FB(S)} × 0.95	-	500	-	μA
Current consumption 2	I _{SS2}	At switching stop, V _{FB} =1.5V	-	70	120	μA
Current consumption during shutdown	I _{SSS}	V _{ON} =0V	-	-	1	μA
EXT pin output current	I _{EXTH}	V _{EXT} =VDD-0.4V	-	-130	-60	mA
	I _{EXTL}	V _{EXT} =0.4V	100	200	-	mA
Oscillation frequency	Fosc	-	1.0	1.2	1.4	MHz
Max. duty ratio	MAXDUTY	V _{FB} =V _{FB(S)} × 0.95	80	85	90	%
PWM/PFM switching duty ratio	PFMDUTY	VDD=V _{OUT(S)} -0.1V, no load	20	28	36	%
Short-circuit protection delay time	t _{PRO}	Product with short-circuit protection, At CSP = 1nF	10	20	30	mS
UVLO release voltage	V _{UVLO+}		1.5	1.65	1.8	V
UVLO hysteresis width	V _{UVLOHYS}		0.05	0.10	0.20	V
High level input voltage	V _{SH}	VDD= 1.8 V to 5.5 V, ON pin	0.9	-	-	V
Low level input voltage	V _{SL}	VDD= 1.8 V to 5.5 V, ON pin	-	-	0.3	V
High level input current	I _{SH}	VDD= 1.8 V to 5.5 V, ON pin	0.2	1.0	2.5	μA

Low level input current	I_{SL}	VDD= 1.8 V to 5.5 V, ON pin	-0.1	-	0.1	μA
Soft start time	tss	-	6	8	13	mS
Efficiency	EFFI	-	-	85	-	%
FB voltage temperature coefficient	$\frac{\Delta V_{FB}}{\Delta T_a}$	Ta =-40°C to +85°C	-	± 100	-	ppm/°C

Note:

1. Set the input voltage as to $1.8 V \leq V_{DD} \leq 5.5 V$ for stabilizing the output voltage and oscillation frequency.
2. $V_{FB}(S)$ is a setting value for FB voltage.
3. $V_{OUT}(S)$ is a setting value for output voltage. V_{OUT} is the typical value of actual output voltage. $V_{OUT}(S)$ can be set by using the rate of V_{FB} and output voltage setting resistors (R1, R2).
4. The short-circuit protection time can be set by the external capacitor, and the maximum set value by the external capacitor is unlimited when an ideal case is assumed. But use CSP = approximately $0.47 \mu F$ as a target maximum value due to the need to consider the discharge time of the capacitor.

External Parts List When Measuring Electrical Characteristics

Element Name	Symbol	Value	Unit
Inductor	L	2.2	μH
Diode	SD	IN5819/IN5817	-
Input capacitor	Cin	10	μF
Output capacitor	Co	22	μF
CSP pin capacitor	CSP	1	nF

Typical Performance Characteristics

1、Output Voltage VS. Output Current (Vout =5.0V)

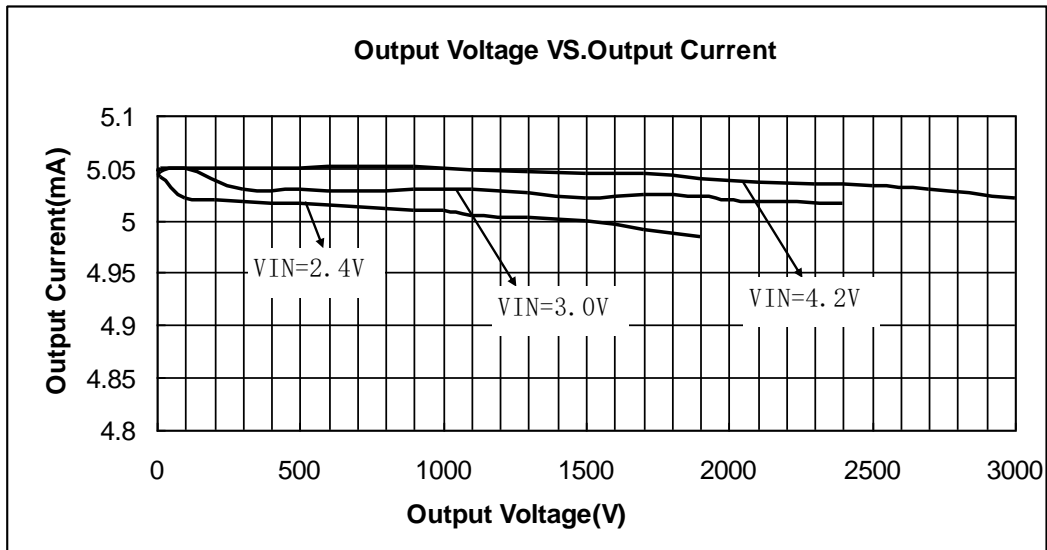

2、Efficiency VS. Output Current (Vout=5.0V)

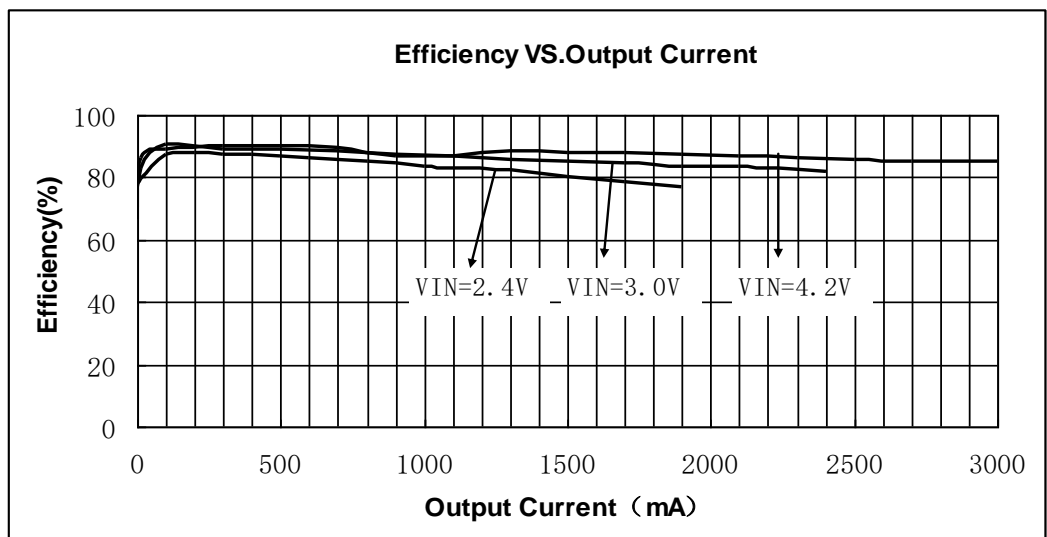

3、VFB VS. Input Voltage (Iout=10mA)

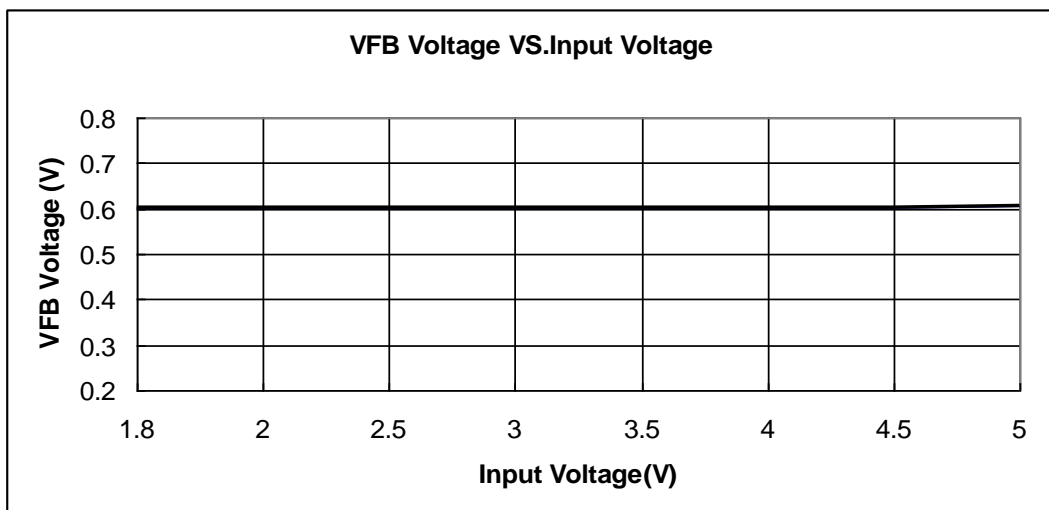

4、 I_{SS1} VS. Input Voltage

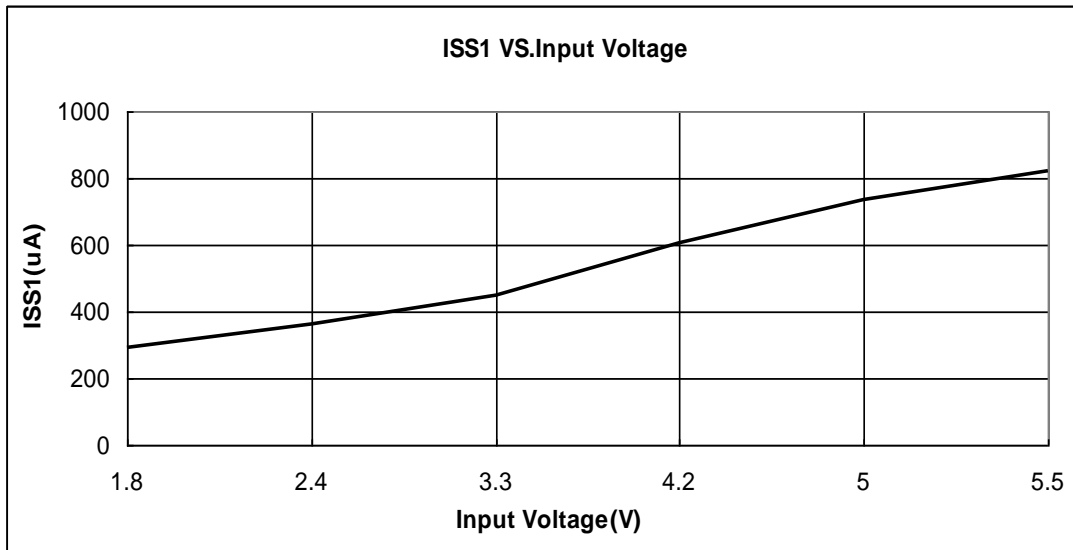

5、Oscillator Frequency VS. Input Voltage

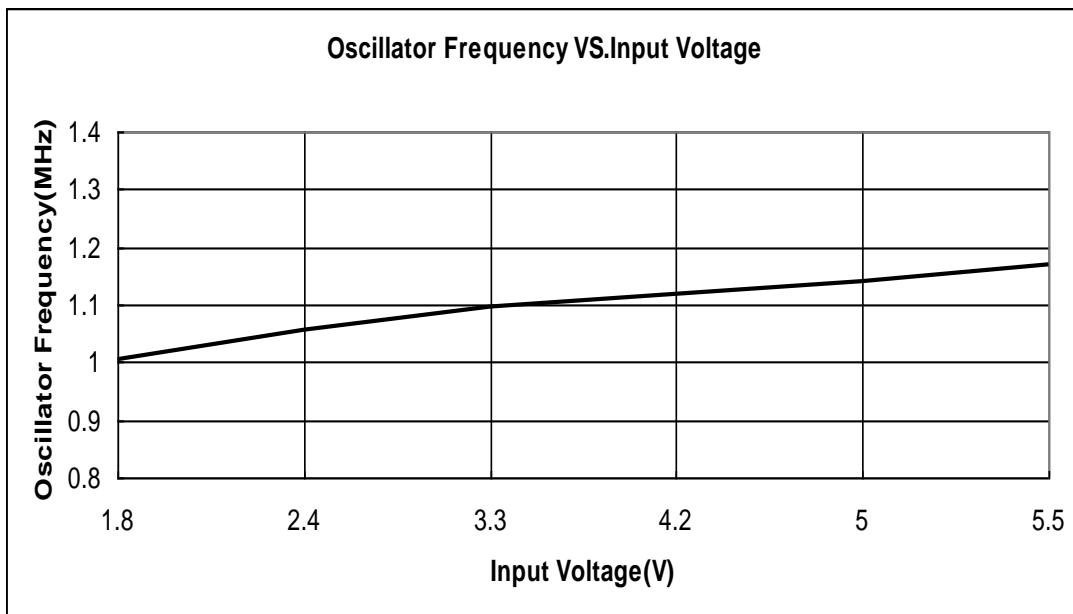

Operation Principles

The ME2179 is a step-up switching regulator controller. Figure 1 shows the basic circuit diagram. Step-up switching regulators start current supply by the input voltage V_{IN} when the Nch power MOSFET is turned on and holds energy in the inductor at the same time. When the Nch power MOSFET is turned off, the CONT pin voltage is stepped up to discharge the energy held in the inductor and the current is discharged to V_{out} through the diode. When the discharged current is stored in C_L , a voltage is generated, and the potential of V_{out} increases until the voltage of the FB pin reaches the same potential as the internal reference voltage.

For the PWM control method, the switching frequency (f_{OSC}) is fixed and the V_{out} voltage is held constant

according to the ratio of the ON time and OFF time (ON duty) of the Nch power MOSFET in each period. For the PWM control method, the Vout voltage is held constant by controlling the ON time.

In the ME2179, the Nch power MOSFET is turned on when the fixed duty cycle is 28% for the PFM control method. When energy is discharged to Vout once and the Vout potential exceeds the set value, the Nch power MOSFET stays in the off status until Vout decreases to the set value or less due to the load discharge. Time Vout decreases to the set value or less depends on the amount of load current, so, the switching frequency varies depending on this current.

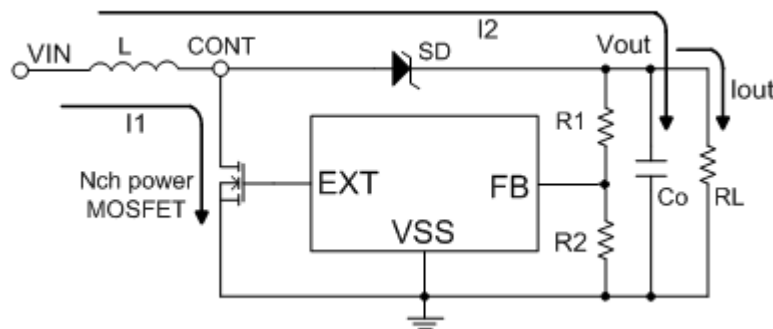

Fig.1 Basic Circuit of Step-up Switching Regulator

The ON duty in the current continuous mode can be calculated by using the equation below. Use the ME2179 in the range where the ON duty is less than the maximum duty. Note that the products with short-circuit protection is set in the timer-latch status if the maximum duty lasts the short-circuit protection delay time (t_{PRO}) or more.

The maximum duty is 85% typ.

$$\text{ONDuty} = \left(1 - \frac{V_{IN}}{V_{out} + V_D}\right) * 100\%$$

The ON time (t_{ON}) can be calculated by using the following equation:

$$t_{ON} = \frac{1}{f_{OSC}} * \text{ONDuty} = \frac{1}{f_{OSC}} * \left(1 - \frac{V_{IN}}{V_{out} + V_D}\right)$$

V_D is the forward voltage of a diode

PWM / PFM switching control

The ME2179 switching regulator controller automatically switches between the pulse width modulation method (PWM) and pulse frequency modulation method (PFM) according to the load current. A low ripple power can be supplied by operating on PWM control for which the pulse width changes from 28% to 85% in the range where the output load current is large. The ME2179 operates on PFM control when the output load current is small and the fixed pulses which have the width of 28% are skipped according to the load current amount. Therefore, the

oscillation circuit intermittently oscillates, reducing the self-current consumption. This avoids decreased efficiency when the output load current is small. The point at which PWM control switches to PFM control varies depending on the external element (inductor, diode, etc.), input voltage value, and output voltage value, and this method achieves high efficiency in the output load current of about 100 μ A.

Soft-start function

The ME2179 has a soft-start circuit. The output voltage (V_{out}) gradually rises after power-on or startup when the ON pin is set to high, suppressing rush current and overshooting the output voltage. The soft-start time (t_{ss}) for the ME2179 is defined as the time from startup until V_{out} reaches 90% of the output set voltage value ($V_{out(S)}$). A reference voltage adjustment method is used as the soft-start method and the reference voltage gradually rises from 0 V after soft-start.

A soft-start performs by controlling the FB pin voltage so that it follows the rise of the reference voltage. After the reference voltage rises once, it is reset to 0 if the ON pin voltage drops to low, the power supply voltage drops to the UVLO detection voltage, or the ME2179 enters the short-circuit protection latch status. A soft-start is performed regardless of conditions when resuming step-up operation.

With ON pin pull-down

When the ON pin is set to the low level, the voltage of the EXT pin is fixed to 0 V, and the external transistor and all internal circuits stop substantially reducing the current consumption. The ON pin is set up as shown in Fig.2 and is internally pulled down by using the depression transistor, so all circuits stop even if this pin is floating. Do not apply a voltage of between 0.3 V and 0.75 V to the ON pin because applying such a voltage increases the current consumption. If the ON/OFF pin is not used, connect it to the VDD pin.

ON Pin	CR Oscillation Circuit	Output Voltage
H	Operates	Set value
L	Stops	$\approx V_{IN}$

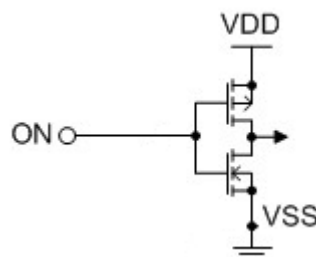
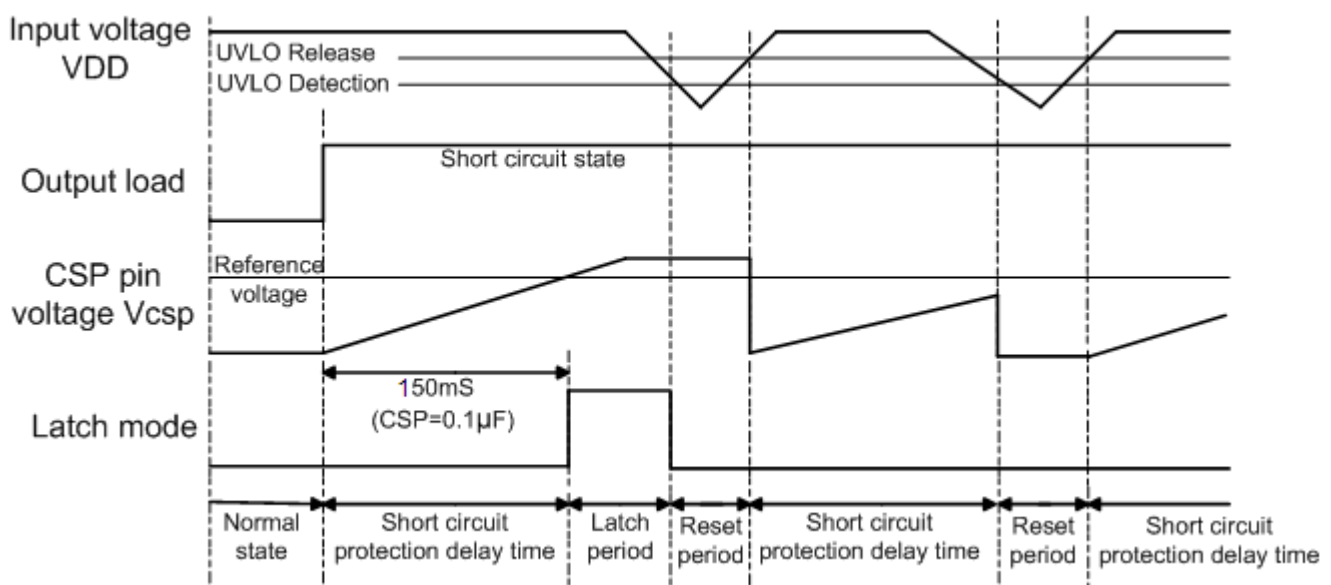

Fig.2

Timer latch type short-circuit protection

The ME2179 incorporates a timer latch type short-circuit protection circuit that stops switching operation if the

output short circuits for a certain time or more. Connect a capacitor (CSP) to the CSP pin to set the delay time of this circuit. The ME2179 operates on the maximum duty if the output voltage drops due to output short-circuiting or other factors. When it enters the maximum duty status, charging the constant current to CSP is started. If this status is held for the short-circuit protection delay time or more, the voltage of the CSP pin exceeds the reference voltage and the IC enters the latch mode. Note that switching operation stops in latch mode but the internal circuits normally operate, which differs from the power-off status. The constant current is continuously charged to CSP even in latch mode, so the voltage of the CSP pin rises to the VDD level. To reset the latch mode of short-circuit protection, lower VDD to the UVLO detection voltage or lower or set the ON pin to the low level.



UVLO function

The ME2179 has a UVLO (under voltage lockout) circuit for avoiding IC malfunctions due to power supply voltage drops. The ME2179 stops switching operation upon UVLO detection and retains the external transistor in the off state. After entering the UVLO detection status once, the soft-start function is reset.

Note, however, that the other internal circuits operate normally and that the status differs from the power-off status.

External parts selection for DC/DC converter

1. Inductor

The recommended L value of ME2179 is 2.2µH for 1.2 MHz products. Note the following when changing the inductance. The inductance (L) has a strong influence on the maximum output current (I_{out}) and efficiency (η). The inductor peak current (I_{pk}) increases when L is decreased, which improves the circuit stability and increases the I_{out} users can obtain. If L is decreased further, the ability of the external transistor to drive the current becomes insufficient, reducing the efficiency and decreasing I_{out}.

The loss due to the I_{pk} of the switching transistor is decreased by increasing L and the efficiency maximizes at a certain L value. If L is increased further, the loss due to the serial resistance of the inductor increases, lowering the efficiency.

Caution: When selecting an inductor, be careful about its allowable current. If a current exceeding the allowable current flows through the inductor, magnetic saturation occurs, substantially lowering the efficiency and destroying ICs due to large current. Therefore, select an inductor such that I_{pk} does not exceed the allowable current. The following equations express I_{pk} in the ideal statuses in the discontinuous and continuous modes :

$$I_{pk} = \sqrt{\frac{2 * I_{out} * (V_{out} + V_D - V_{IN})}{f_{OSC} * L}} \text{ (A)} \quad \text{(Discontinuous mode)}$$

$$I_{pk} = \frac{V_{out} + V_D}{V_{IN}} * I_{out} + \frac{(V_{out} + V_D - V_{IN}) * V_{IN}}{2 * (V_{out} + V_D) * f_{OSC} * L} \text{ (A)} \quad \text{(Continuous mode)}$$

F_{OSC} is oscillation frequency, V_D is the forward voltage of a diode. The reference value is 0.4 V. However, current exceeding the above equation flows because conditions are practically not ideal. Perform sufficient evaluation with actual application.

2. Diode

Use an external diode that meets the following requirements:

- Low forward voltage (Schottky barrier diode or similar type) : ($V_F < 0.3$ V)
- High switching speed: (50 ns max.)
- Reverse voltage: $V_{OUT} + V_F$ or more
- Rated current: I_{PK} or more

3. Capacitor (C_{IN} , C_O)

To improve efficiency, an input capacitor (C_{in}) lowers the power supply impedance and averages the input current. Select C_{in} according to the impedance of the power supply used. The recommended capacitance is 10 μ F for ME2179. An output capacitor (C_{out}), which is used to smooth the output voltage, requires a capacitance larger than that of the step-down type because the current is intermittently supplied from the input to the output side in the step-up type. A 22 μ F ceramic capacitor is recommended for ME2179. However, a higher capacitance is recommended if the output voltage is high or the load current is large. If the output voltage or load current is low, about 10 μ F can be used without problems.

Select C_{out} after sufficient evaluation with actual application.

A ceramic capacitor can be used for both the input and output.

4. Enhancement MOS FET type

Use an Nch power MOS FET. A MOS FET that has low ON-resistance (R_{on}) and input capacitance (C_{iss}) is ideal for gaining efficiency. The ON-resistance and input capacitance generally have a tradeoff relationship. ON-resistance is efficient in the range where the output current is high with relatively low frequency switching, and input capacitance is efficient in the range where the output current is medium to low with high frequency switching. Therefore, select a MOS FET for which the ON-resistance and input capacitance are optimum under your usage conditions. The input voltage (VDD) is supplied as the gate voltage of a MOSFET, so select a MOSFET for which the gate withstand voltage is higher than the maximum value used for the input voltage, and for which the drain withstand voltage is greater than or equal to the output voltage (V_{out}) + the forward voltage of the diode (V_D). If a MOSFET for which the threshold value is near the UVLO detection voltage is used, a high current flows upon power-on, and, in the worst case, the output voltage might not increase and the timer latch type short-circuit protection circuit might operate. Therefore, select a MOS FET for which the threshold value is sufficiently lower than the UVLO detection voltage.

5. Capacitor for setting short-circuit protection delay time (CSP) (products with short-circuit protection)

For ME2179, the short-circuit protection delay time can be set to any value by using an external capacitor. Connect the capacitor between the CSP and VSS pins. Select the capacitor value according to the equation below, however, that the equation and figure show a theoretical value assuming an ideal capacitor value and typ. IC conditions. Variations of the capacitor and IC are not considered. For the IC variations, see the short-circuit protection delay time (t_{PRO}) in “Electrical Characteristics”.

$$CSP = \frac{t_{PRO}(ms) * 0.2 * 10^{-3}}{0.6} \quad (\mu F)$$

6. Output voltage setting resistors (R1 , R2)

For ME2179, V_{out} can be set to any value by using external divider resistors. Connect the divider resistors between the V_{out} and VSS pins. Because $V_{fb} = 0.6 V$ typ., V_{out} can be calculated by using the following equation :

$$V_{out} = \frac{R1+R2}{R2} * 0.6(V)$$

Connect divider resistors R1 and R2 as close to the IC as possible to minimize the effects of noise.

The typical constants based on our evaluation are shown in the next Table:

Vout(S) (V)	VDD (V)	R1 (KΩ)	R2 (KΩ)	L (μH)	Cout (μF)
3.32	2.4	68	15	2.2	22
5	3.3	110	15	3.3	22

7. Precautions

- Mount external capacitors, a diode, and a coil as close as possible to the IC.
- Characteristics ripple voltage and spike noise occur in IC containing switching regulators. Moreover rush current flows at the time of a power supply injection. Because these largely depend on the inductor, the capacitor and impedance of power supply used, fully check them using an actually mounted model.
- The 0.1 μF capacitor connected between the VDD and VSS pins is a bypass capacitor. It stabilizes the power supply in the IC when application is used with a heavy load, and thus effectively works for stable switching regulator operation. Allocate the bypass capacitor as close to the IC as possible, prioritized over other parts.
- Although the IC contains a static electricity protection circuit, static electricity or voltage that exceeds the limit of the protection circuit should not be applied.
- The power dissipation of the IC greatly varies depending on the size and material of the board to be connected. Perform sufficient evaluation using an actual application before designing.

Package Information

- Package Type: SOT23-6

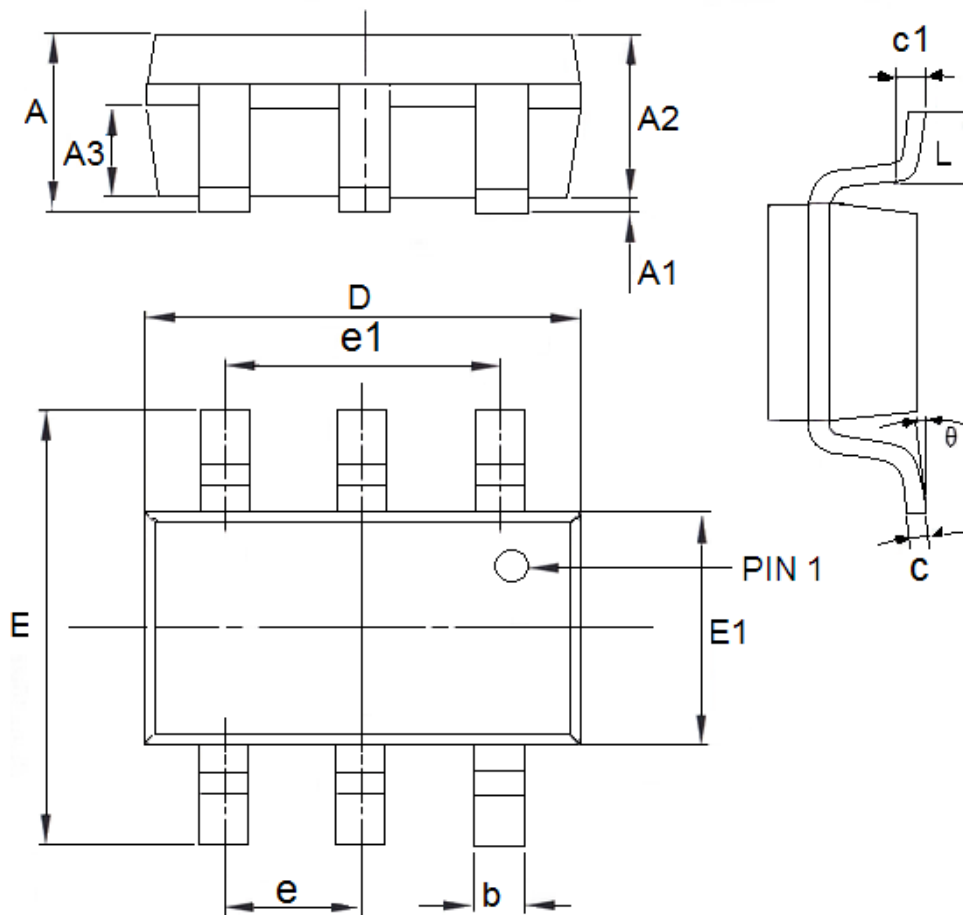

DIM	Millimeters		Inches	
	Min	Max	Min	Max
A	1.05	1.45	0.0413	0.0571
A1	0	0.15	0.0000	0.0059
A2	0.9	1.3	0.0354	0.0512
A3	0.55	0.75	0.0217	0.0295
b	0.25	0.5	0.0098	0.0197
c	0.1	0.25	0.0039	0.0098
D	2.7	3.12	0.1063	0.1228
e1	1.9(TYP)		0.0748(TYP)	
E	2.6	3.1	0.1024	0.1220
E1	1.4	1.8	0.0551	0.0709
e	0.95(TYP)		0.0374(TYP)	
L	0.25	0.6	0.0098	0.0236
theta	0	8°	0.0000	8°
c1	0.2(TYP)		0.0079(TYP)	

- The information described herein is subject to change without notice.
- Nanjing Micro One Electronics Inc is not responsible for any problems caused by circuits or diagrams described herein whose related industrial properties, patents, or other rights belong to third parties. The application circuit examples explain typical applications of the products, and do not guarantee the success of any specific mass-production design.
- Use of the information described herein for other purposes and/or reproduction or copying without the express permission of Nanjing Micro One Electronics Inc is strictly prohibited.
- The products described herein cannot be used as part of any device or equipment affecting the human body, such as exercise equipment, medical equipment, security systems, gas equipment, or any apparatus installed in airplanes and other vehicles, without prior written permission of Nanjing Micro One Electronics Inc.
- Although Nanjing Micro One Electronics Inc exerts the greatest possible effort to ensure high quality and reliability, the failure or malfunction of semiconductor products may occur. The user of these products should therefore give thorough consideration to safety design, including redundancy, fire-prevention measures, and malfunction prevention, to prevent any accidents, fires, or community damage that may ensue.