

Small Package, High Performance, Asynchronous Boost For 6 series or 3x13 WLED Driver

General Description

The ME2214 is a high frequency, asynchronous boost converter. The internal MOSFET can support up to 6 series or 3x13 White LEDs for backlighting and OLED power application, and the internal soft start function can reduce the inrush current. The device operates with 1-MHz fixed switching frequency to allow small external components and to simplify possible EMI problems. Moreover, the IC comes with 26V over voltage protection to allow inexpensive and small-output capacitors with lower voltage ratings. The LED current is initially set with the external sense resistor R_s .

Features

- VIN Operating Range : 2.5V to 5.5V
- Internal Power N-MOSFET Switch
- Wide Range for PWM Dimming (100Hz to 200kHz)
- 1MHz Switching Frequency
- Minimize the External Component Counts
- Internal Soft Start
- Internal Compensation
- Under Voltage Protection
- Over Voltage Protection
- Over Temperature Protection

Typical Application

- Cellular Phones
- Digital still cameras
- PDAs and Smart Phones and MP3 and OLED.
- Probable Instruments

Package

- 6-pin SOT23-6

Typical Application circuit

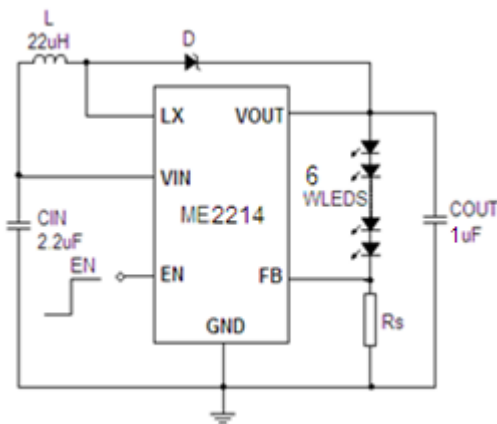

$$I_{LED} = 20mA, \quad R_s = 10\Omega$$

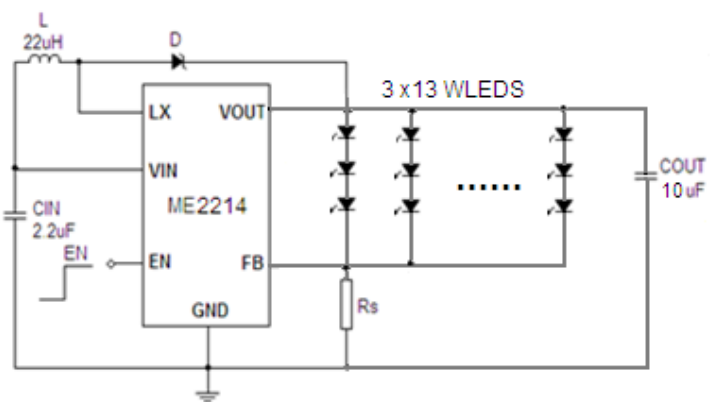

$$I_{LED} = 260mA, \quad R_s = 0.77\Omega$$

Suggesting : The output ceramic capacitor of 1µF or 10µF is recommended for the ME2214 applications for driving 6 series WLEDs. The output ceramic capacitor of 10µF is recommended for the ME2214 applications for driving 3x13 WLEDs. For better voltage filtering, ceramic capacitors with low ESR are recommended.

Selection Guide

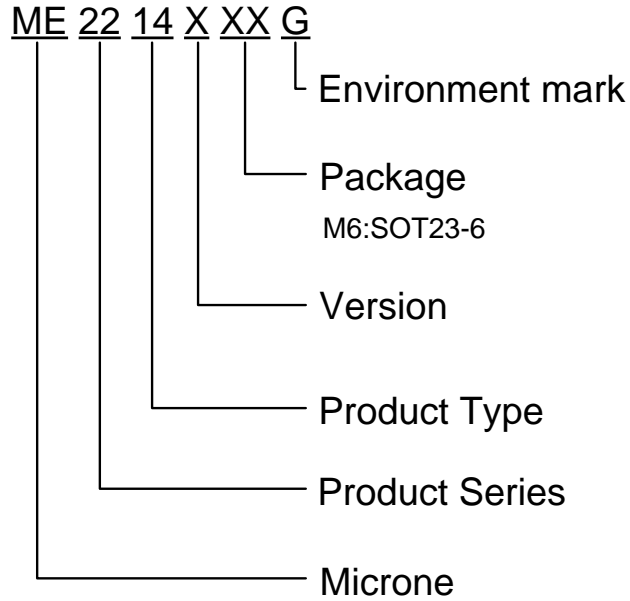

product series	product description
ME2214AM6G	Package: SOT23-6

NOTE: If you need other voltage and package, please contact our sales staff.

Pin Configuration & Pin Assignment

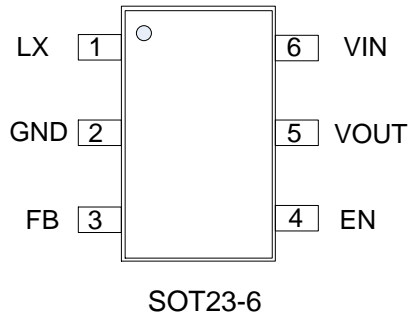

Pin Assignment

Pin Number	Name	Function
1	LX	Switch
2	GND	Ground
3	FB	Feedback
4	EN	Chip Enable
5	VOUT	Output
6	VIN	Input

Block Diagram

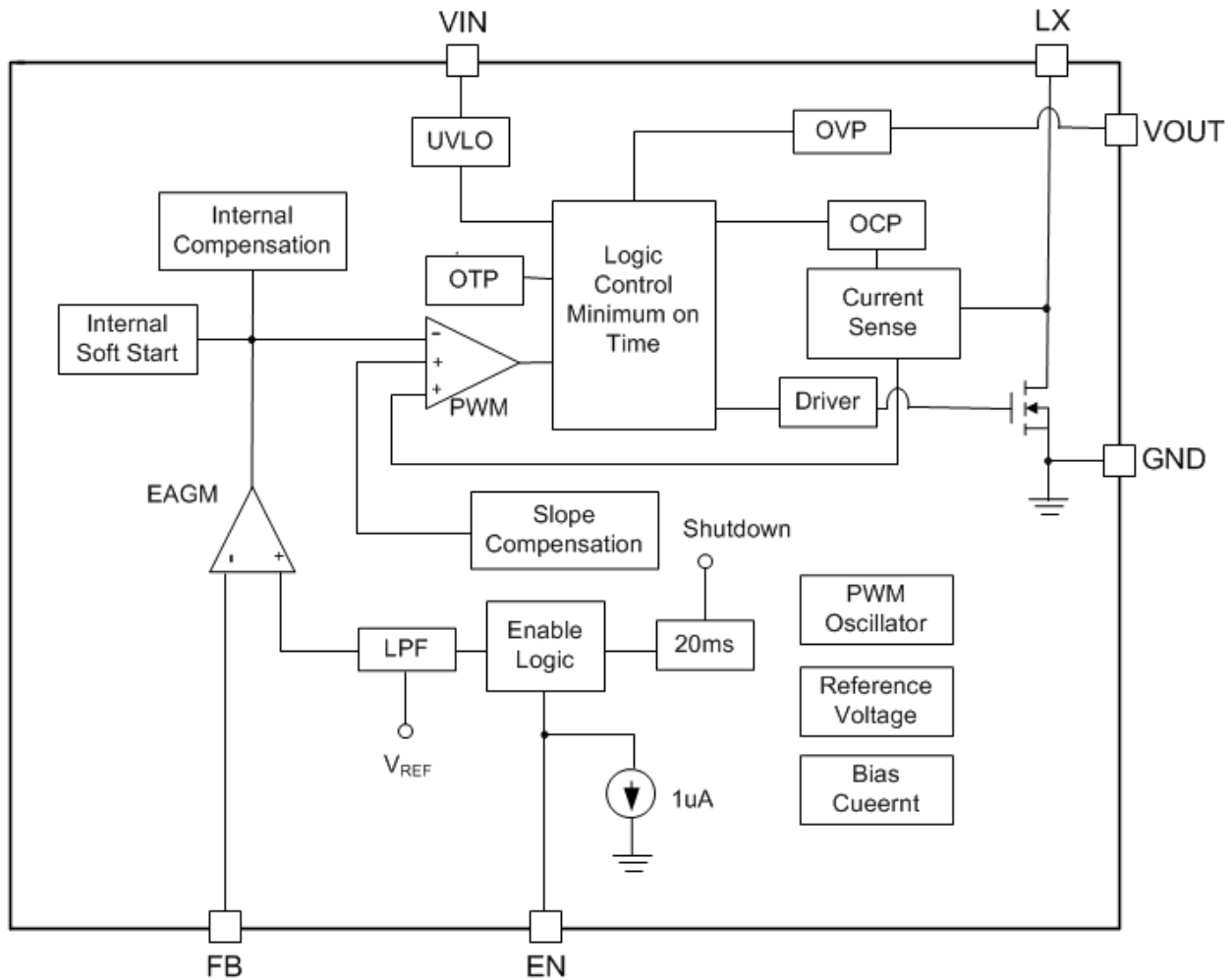

Absolute Maximum Ratings

Parameter	Symbol	Ratings	Units
Input Voltage	V_{IN}	-0.3V~6V	V
LX Pin Voltage	LX	-0.3V~30V	V
FB Pin Voltage	FB	-0.3V~6V	V
Operating Temperature Range	T_{OPR}	-40°C~85°C	°C
Storage Temperature Range	T_{STG}	-65°C~125°C	°C
Lead Temperature (Soldering, 10 sec)	T_L	260°C	°C
Internal Power Dissipation (SOT23-6)	P_D	400	mW

Electrical Characteristic

$T=25^{\circ}\text{C}$, $V_{\text{IN}}=V_{\text{EN}}=3.7\text{V}$, $L=22\mu\text{H}$, $C_{\text{IN}}=2.2\mu\text{F}$, $C_{\text{OUT}}=10\mu\text{F}$, unless otherwise noted.

Parameter	Symbol	Condition	Min	Typ	Max	Unit
Input Voltage Range	V_{IN}		2.5	3.7	5.5	V
Under Voltage Lock Out	V_{UVLO}		2	2.2	2.45	V
UVLO Hystersis				0.1		V
Supply Current	ISS	No external Component		0.8	1.5	mA
Shutdown Current	I_{SHDN}	No external Component $V_{\text{EN}}=0\text{V}$	1	3	5	μA
Oscillator Frequency	F_{OSC}		0.85	1.1	1.5	MHz
Maximum Duty Cycle			90	92		%
Feedback Voltage	V_{FB}		190	200	210	mV
On Resistance	$R_{\text{DS(ON)}}$			0.7	1.2	Ω
EN Threshold	Logic-High Voltage	V_{IH}	1.6			V
	Logic-Low Voltage	V_{IL}			0.9	V
Over-Voltage Threshold	V_{OVP}		23	26	30	V
Over-Current Threshold	I_{OCP}		1	1.2		A
Efficiency	η	$I_{\text{LED}}=20\text{mA}$		85		%
Over Temperature Shutdown	OTS			150		$^{\circ}\text{C}$

Typical Operating Characteristics

1. Efficiency vs. Output Current (3 White LEDs)

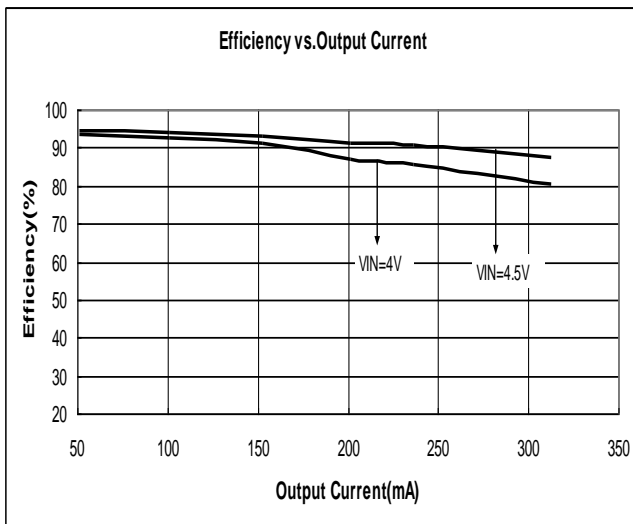

2. Efficiency vs. Input Voltage (6 White LEDs)

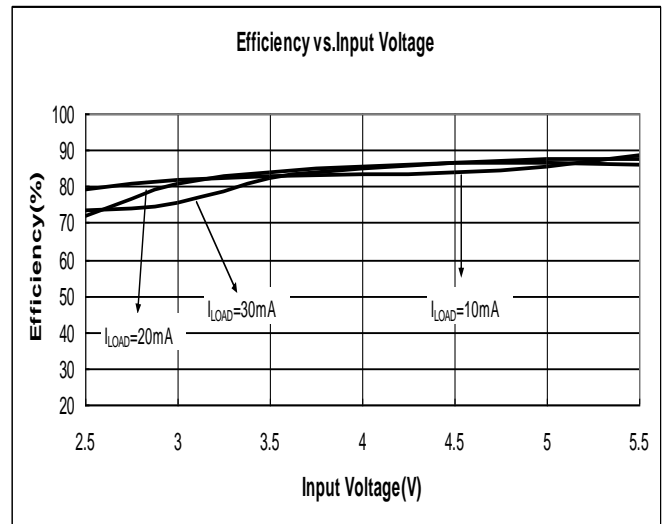

3. Frequency vs. Input Voltage ($I_{LED}=20mA$)

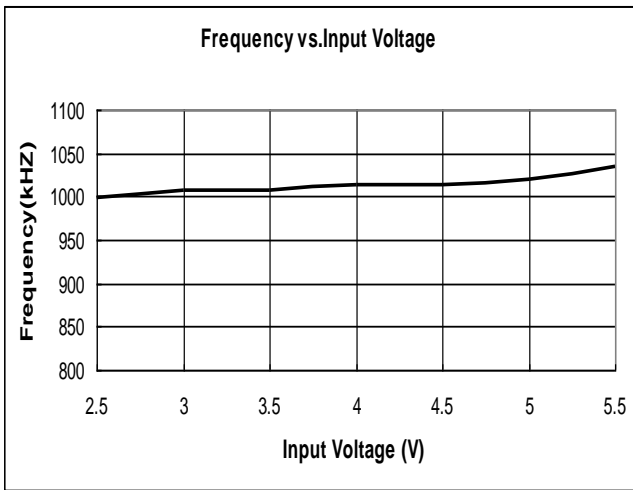

4. Frequency vs. Temperature ($V_{IN}=3.7V, I_{LED}=20mA$)

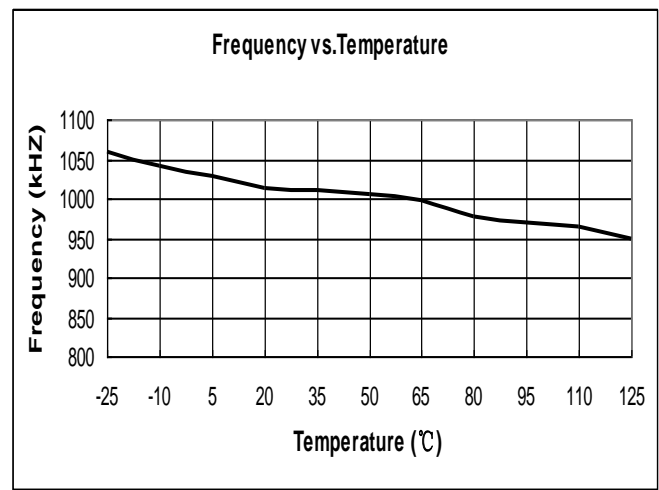

5. V_{FB} vs. Input Voltage (6 White LEDs, $I_{LED}=20mA$)

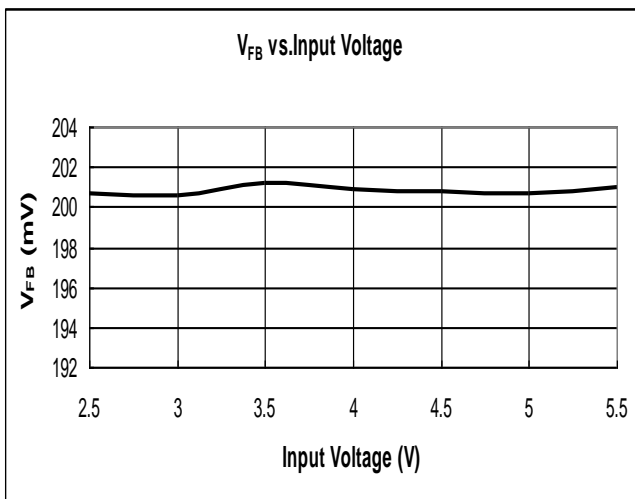

6. V_{FB} vs. Temperature ($I_{LED}=20mA$)

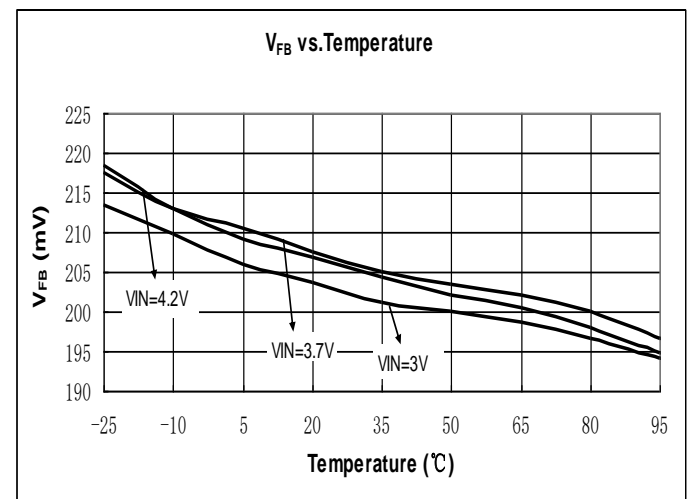

7. V_{FB} vs. Output Current (6 White LEDs)

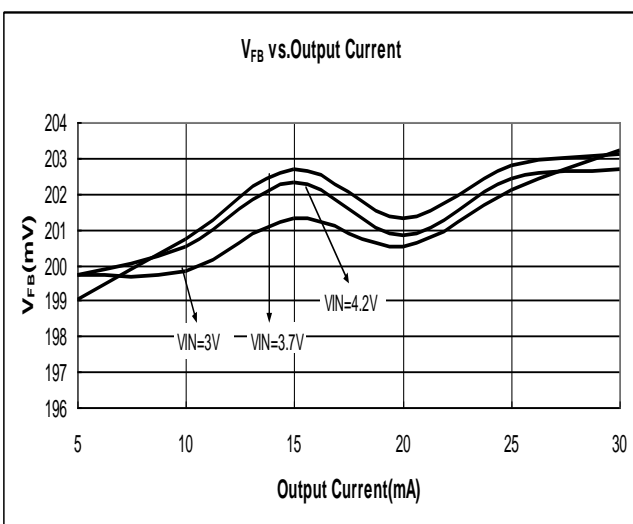

8. Enable Voltage vs. Input Voltage (6 White LEDs)

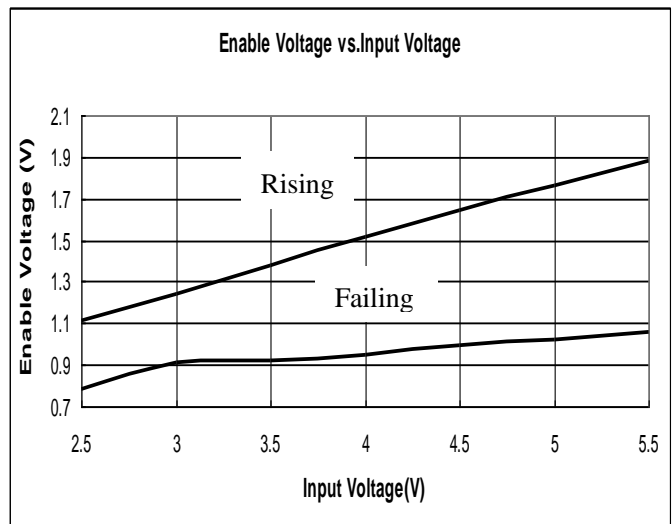

Applications Information

LED Current Setting

The loop of Boost structure will keep the FB pin voltage equal to the reference voltage V_{FB} . Therefore, when R_S connects FB pin and GND, the current flows from V_{OUT} through LED and R_S to GND will be decided by the current on R_S , which is equal to following equation.

$$I_{LED} = \frac{V_{FB}}{R_S}$$

Dimming Control

a. Using a PWM Signal to EN Pin

For controlling the LED brightness, the ME2214 can perform the dimming control by applying a PWM signal to EN pin. A low pass filter is implemented inside chip to reduce the slew rate of I_{WLED} for preventing the audio noise. The internal soft start and the wide range dimming frequency from 200 to 200kHz can eliminate inrush current and audio noise when dimming. The average LED current is proportional to the PWM signal duty cycle. The magnitude of the PWM signal should be higher than the maximum enable voltage of EN pin, in order to let the dimming control perform correctly.

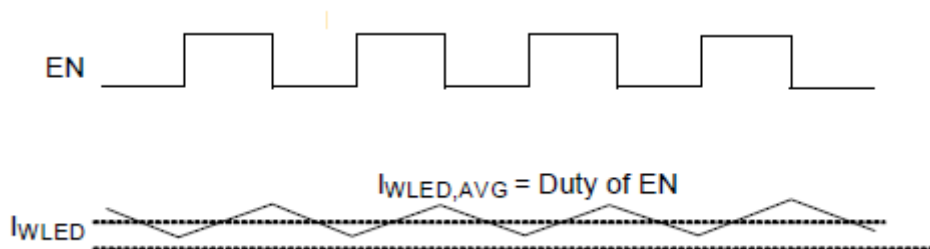

Figure 1. PWM Dimming

b. Using a DC Voltage

Using a variable DC voltage to adjust the brightness is a popular method in some applications. The dimming control using a DC voltage circuit is shown in Figure 2. As the DC voltage increases, the current pass through R_3 increasingly and the voltage drop on R_3 increase, i.e. the LED current decreases. For example, if the V_{DC} range is from 0V to 2.8V and assume the ME2214 is selected which V_{FB} is equal to 0.2V, the selection of resistors in Figure 2 sets the LED current from 21mA to 0mA. The LED current can be calculated by the following equation.

$$I_{LED} = \frac{V_{FB} - \frac{R_3 \times (V_{DC} - V_{FB})}{R_4}}{R_S}$$

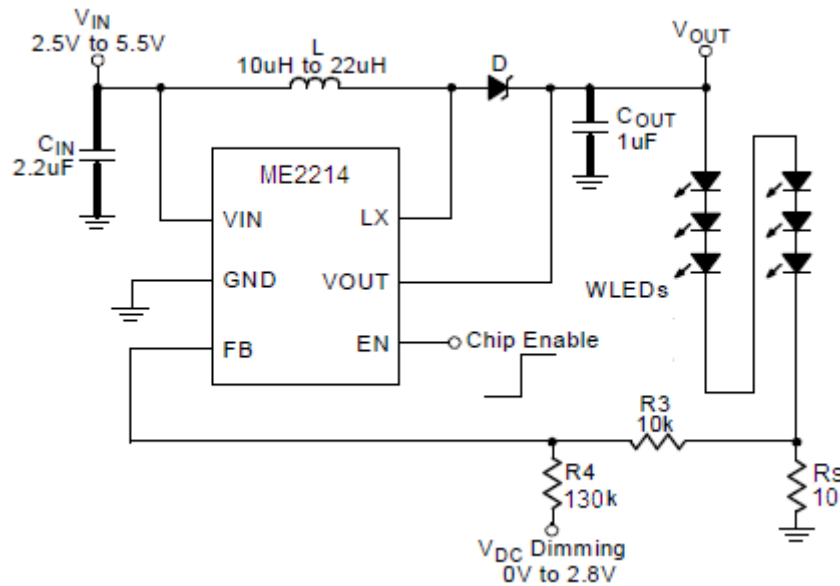

Figure 2. Dimming Control Using a DC Voltage for the ME2214

c. Using a Filtered PWM signal

Another common application is using a filtered PWM signal as an adjustable DC voltage for LED dimming control. A filtered PWM signal acts as the DC voltage to regulate the output current. The recommended application circuit is shown as Figure 3. In this circuit, the output ripple depends on the frequency of PWM signal. For smaller output voltage ripple (<100mV), the recommended frequency of 2.8V PWM signal should be above 2kHz. To fix the frequency of PWM signal and change the duty cycle of PWM signal can get different output current. The LED current can be calculated by the following equation.

$$I_{LED} = \frac{V_{FB} - \frac{R3 \times (V_{PWM} \times Duty - V_{FB})}{R4 + R_{DC}}}{R_S}$$

By the above equation and the application circuit shown in Figure 3, and assume the ME2214 is selected which V_{FB} is equal to 0.2V. Figure 4 shows the relationship between the LED current and PWM duty cycle. For example, when the PWM duty is equal to 60%, the LED current will be equal to 8.6mA. When the PWM duty is equal to 40%, the LED current will be equal to 12.9mA.

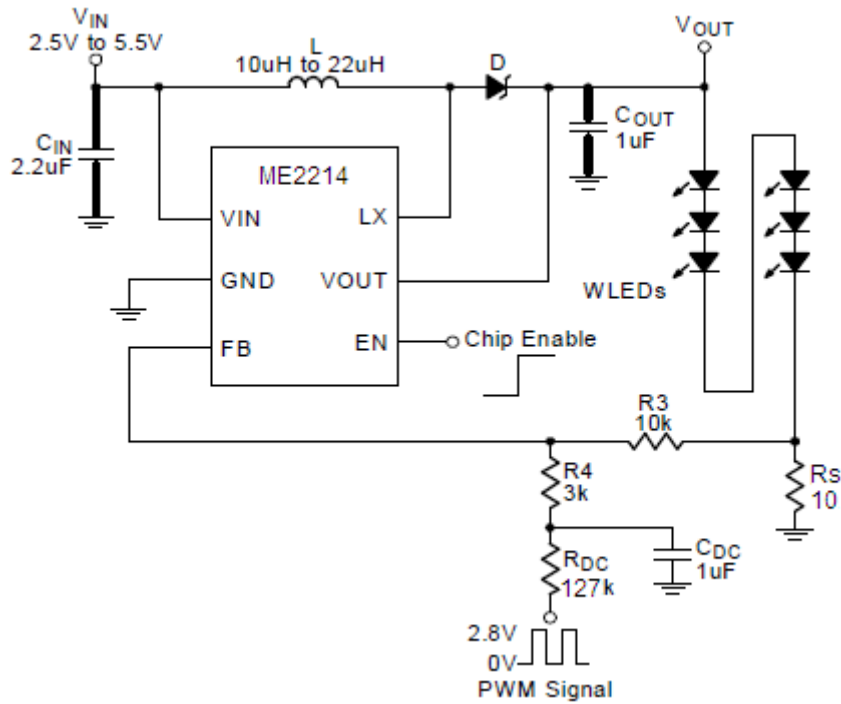

Figure 3. Filtered PWM Signal for LED Dimming Control of the ME2214

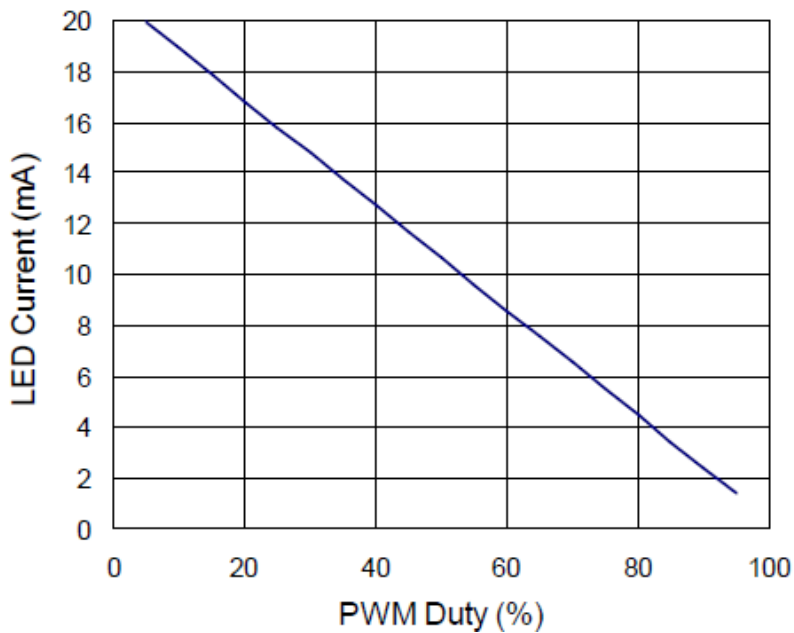

Figure 4

Application for Driving 3 x 13WLEDs

The ME2214 can driver different WLEDs topology. For example, the Figure 5 shows the 3x13WLEDs and total current is equal to 260mA. The total WLEDs current can be set by the R_S which is equal to following equation.

$$I_{\text{Total}} = \frac{V_{\text{FB}}}{R_S}$$

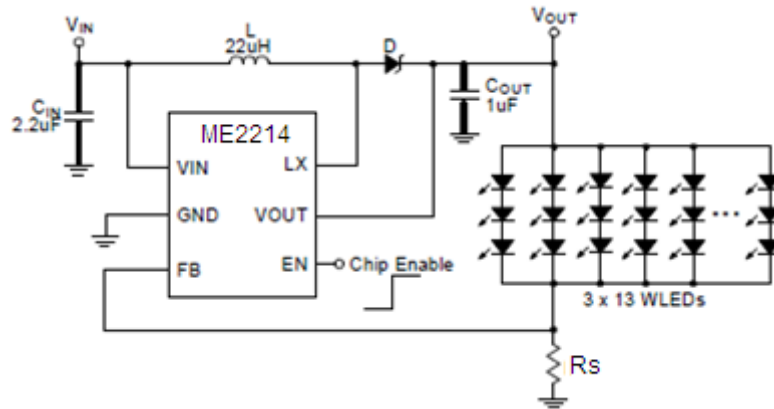

Figure 5. Application for Driving 3 X 13WLEDs

Soft-Start

The function of soft-start is made for suppressing the inrush current to an acceptable value at the beginning of power on. The soft-start function is built-in the ME2214 by clamping the output voltage of error amplifier so that the duty cycle of the PWM will be increased gradually in the soft-start period.

Current Limiting

The current flow through inductor as charging period is detected by a current sensing circuit. As the value comes across the current limiting threshold, the N-MOSFET will be turned off so that the inductor will be forced to leave charging stage and enter discharging stage. Therefore, the inductor current will not increase over the current limiting threshold.

OVP/UVLO/OTP

The Over Voltage Protection is detected by a junction breakdown detecting circuit. Once V_{OUT} goes over the detecting voltage, LX pin stops switching and the power N-MOSFET will be turned off. Then, the V_{OUT} will be clamped to be near V_{OVP} . As the output voltage is higher than a specified value or input voltage is lower than a specified value, the chip will enter protection mode to prevent abnormal function. As the die temperature $> 150^{\circ} C$, the chip also will enter protection mode. The power MOSFET will be turned off during protection mode to prevent abnormal operation.

Inductor Selection

The recommended value of inductor for 10 WLEDs applications is from 10uH to 22uH. Small size and better efficiency are the major concerns for portable devices, such as the ME2214 used for mobile phone. The inductor should have low core loss at 1MHz and low DCR for better efficiency. The inductor saturation current rating should be considered to cover the inductor peak current.

Capacitor Selection

Input ceramic capacitor of 2.2 μ F and output ceramic capacitor of 1 μ F are recommended for the ME2214 applications for driving 6 series WLEDs. For better voltage filtering, ceramic capacitors with low ESR are recommended. X5R and X7R types are suitable because of their wider voltage and temperature ranges.

Layout Considerations

- A full GND plane without gap break.
- LX node copper area should be minimized for reducing EMI.
- The input capacitor CIN should be placed as close as possible to Pin 6.
- The output capacitor COUT should be connected directly from the Pin 5 to ground rather than across the LEDs.
- FB node copper area should be minimized and kept far away from noise sources (Pin 1, Pin 5, Pin 6).
- The Inductor is far away receiver and microphone.
- R_S should be placed as close as possible to the ME2214

Package Information

- Package Type:SOT23-6

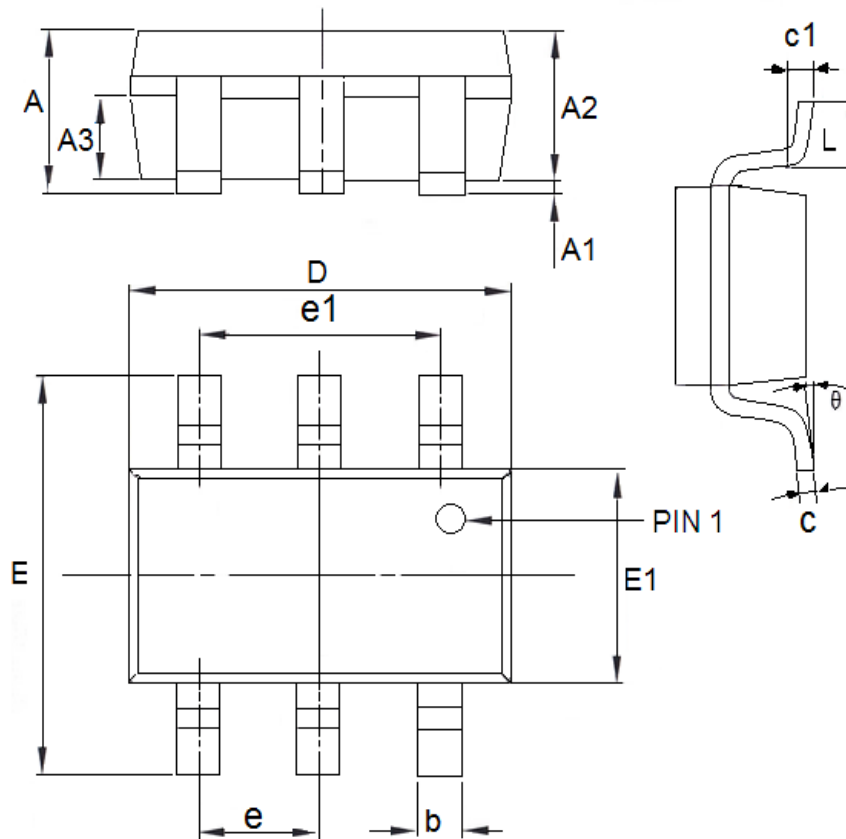

DIM	Millimeters		Inches	
	Min	Max	Min	Max
A	1.05	1.45	0.0413	0.0571
A1	0	0.15	0.0000	0.0059
A2	0.9	1.3	0.0354	0.0512
A3	0.55	0.75	0.0217	0.0295
b	0.25	0.5	0.0098	0.0197
c	0.1	0.25	0.0039	0.0098
D	2.7	3.12	0.1063	0.1228
e1	1.9(TYP)		0.0748(TYP)	
E	2.6	3.1	0.1024	0.1220
E1	1.4	1.8	0.0551	0.0709
e	0.95(TYP)		0.0374(TYP)	
L	0.25	0.6	0.0098	0.0236
θ	0	8°	0.0000	8°
c1	0.2(TYP)		0.0079(TYP)	

- The information described herein is subject to change without notice.
- Nanjing Micro One Electronics Inc is not responsible for any problems caused by circuits or diagrams described herein whose related industrial properties, patents, or other rights belong to third parties. The application circuit examples explain typical applications of the products, and do not guarantee the success of any specific mass-production design.
- Use of the information described herein for other purposes and/or reproduction or copying without the express permission of Nanjing Micro One Electronics Inc is strictly prohibited.
- The products described herein cannot be used as part of any device or equipment affecting the human body, such as exercise equipment, medical equipment, security systems, gas equipment, or any apparatus installed in airplanes and other vehicles, without prior written permission of Nanjing Micro One Electronics Inc.
- Although Nanjing Micro One Electronics Inc exerts the greatest possible effort to ensure high quality and reliability, the failure or malfunction of semiconductor products may occur. The user of these products should therefore give thorough consideration to safety design, including redundancy, fire-prevention measures, and malfunction prevention, to prevent any accidents, fires, or community damage that may ensue.