



## Low power consumption, Low dropout voltage, With CE function

### General Description

ME6213 series are highly precise, low power consumption, high voltage, positive voltage regulators manufactured using CMOS and laser trimming technologies. The series provides large currents with a significantly small dropout voltage.

The current limiter's foldback circuit also operates as a short protect for the output current limiter and the output pin. The CE function allows the output of regulator to be turned off, resulting in greatly reduced power consumption.

### Typical Application

- Battery powered equipment
- Communication tools
- Mobile phones
- Portable games
- Portable AV systems
- Cameras, Video systems
- Reference voltage sources

### Features

- Highly Accurate:  $V_{out}=3.3V: \pm 1\%$   
Others:  $\pm 2\%$
- Output voltage range: 1.2V~5.0V
- Low power consumption: 7.5uA(TYP.)
- Large output current:  
300mA ( $V_{IN}=3.8V, V_{OUT}=2.8V$ )
- Input voltage: up to 6 V
- Dropout voltage:  
0.11V at 100mA and 0.23V at 200mA
- CE Pin Function : Active High
- Short-circuit Current: 45mA(TYP.)
- Excellent Input Stability
- Be available to regulator and reference voltage

### Package

- 5-pin SOT23-5
- 6-pin DFN2×2-6L

## Typical Application Circuit

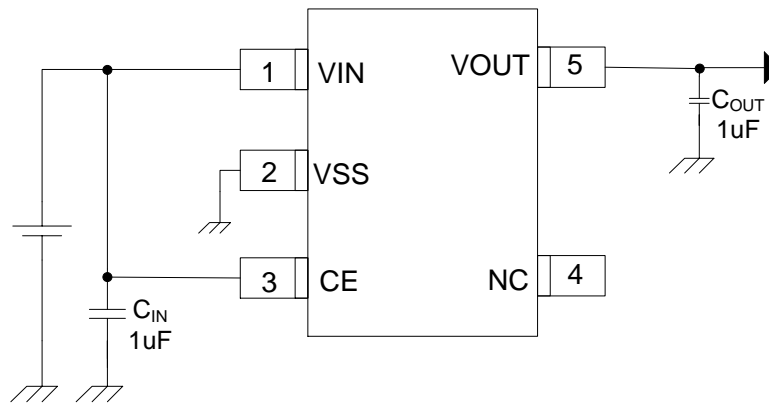

## Selection Guide

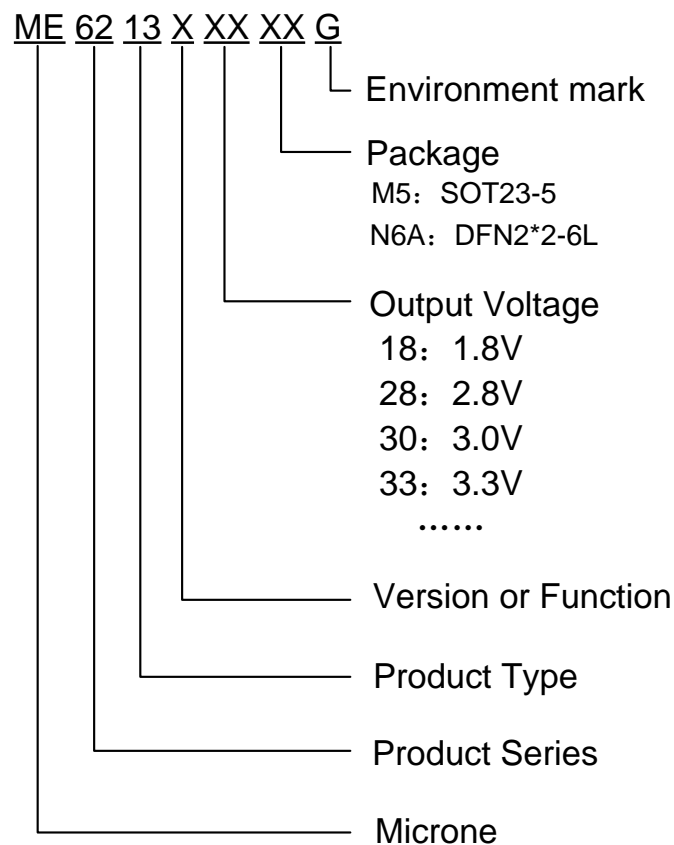

product series	Output voltage	Package
ME6213C18M5G	1.8V	SOT23-5
ME6213C28M5G	2.8V	SOT23-5
ME6213C30M5G	3.0V	SOT23-5
ME6213C33M5G	3.3V	SOT23-5
ME6213C33N6AG	3.3V	DFN2*2-6L

**NOTE:** If you need other voltage and package, please contact our sales staff.

## Pin Configuration

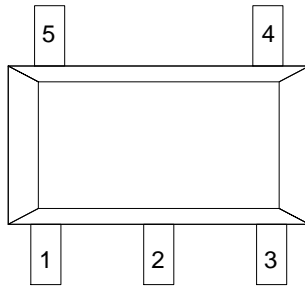

SOT23-5

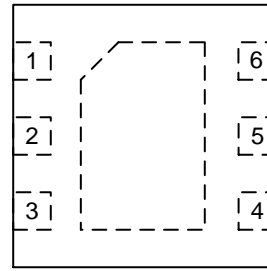

DFN2\*2-6L

## Pin Assignment

Pin Number	Pin Name	Functions
<b>SOT23-5</b>		
1	$V_{IN}$	Power Input
2	$V_{SS}$	Ground
3	CE	ON / OFF Control
4	NC	No Connect
5	$V_{OUT}$	Output

Pin Number	Pin Name	Functions
<b>DFN2×2-6L</b>		
1	CE	ON / OFF Control
2	$V_{SS}$	Ground
3	$V_{IN}$	Power Input
4	$V_{OUT}$	Output
5	NC	No Connect
6	NC	No Connect

## Block Diagram

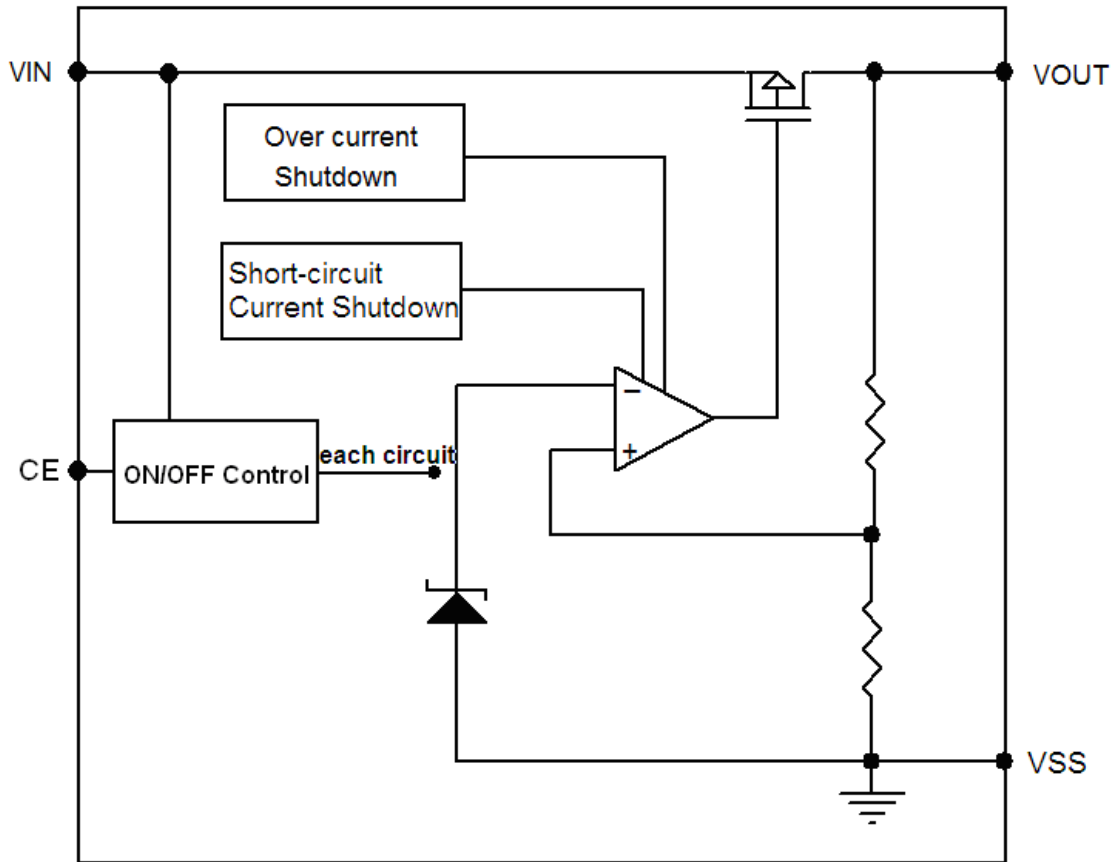

## Absolute Maximum Ratings

Parameter	Symbol	Ratings	Units
Input Voltage	$V_{IN}$	6.5	V
Output Current	$I_{OUT}$	420	mA
Output Voltage	$V_{OUT}$	$V_{SS}-0.3 \sim V_{IN} + 0.3$	V
CE Pin Voltage	$V_{CE}$	$V_{SS}-0.3 \sim V_{IN} + 0.3$	V
Power Dissipation	SOT23-5 $P_D$	250	mW
Operating Temperature Range	$T_{OPR}$	$-40 \sim +85$	$^{\circ}C$
Storage Temperature Range	$T_{STG}$	$-55 \sim +150$	$^{\circ}C$
Lead Temperature		$260^{\circ}C, 4sec$	

## Electrical Characteristics

### ME6213C28

( $V_{IN} = V_{OUT} + 1V$ ,  $V_{CE} = V_{IN}$ ,  $C_{IN} = C_{OUT} = 1\mu F$ ,  $T_a = 25^{\circ}C$ , unless otherwise noted)

Parameter	Symbol	Conditions	Min.	Typ.	Max.	Units
Output Voltage	$V_{OUT(E)}$ (Note 2)	$I_{OUT} = 30mA$ , $V_{IN} = V_{OUT} + 1V$	X 0.98	$V_{OUT(T)}$ (Note 1)	X 1.02	V
Input Voltage	$V_{IN}$		2.8		6	V
Maximum Output Current	$I_{OUTMAX}$	$V_{IN} = V_{OUT} + 1V$		300		mA
Load Regulation	$\Delta V_{OUT}$	$V_{IN} = V_{OUT} + 1V$ ,		4		mV

		$1\text{mA} \leq I_{\text{OUT}} \leq 100\text{mA}$				
Dropout Voltage(Note 1)	$V_{\text{DIF1}}$	$I_{\text{OUT}} = 100\text{mA}$		110		mV
	$V_{\text{DIF2}}$	$I_{\text{OUT}} = 200\text{mA}$		230		mV
Supply Current	$I_{\text{SS}}$	$V_{\text{IN}} = V_{\text{OUT}} + 1\text{V}$		7.5		$\mu\text{A}$
Stand-by Current	$I_{\text{CEL}}$	$V_{\text{CE}} = 0\text{V}$		0.02		$\mu\text{A}$
Line Regulation	$\Delta V_{\text{OUT}}$	$I_{\text{OUT}} = 30\text{mA}$ $V_{\text{OUT}} + 1\text{V} \leq V_{\text{IN}} \leq 6\text{V}$		5		mV
CE "High" Voltage	$V_{\text{CEH}}$	Start up	1.0			V
CE "Low" Voltage	$V_{\text{CEL}}$	Shut down			0.5	V
Short-circuit Current	$I_{\text{SHORT}}$	$V_{\text{IN}} = V_{\text{OUT}} + 1\text{V}$ , $V_{\text{CE}} = V_{\text{IN}}$ , $V_{\text{OUT}} = 0\text{V}$		45		mA
Over Current Protection	$I_{\text{limit}}$	$V_{\text{IN}} = 3.8\text{V}$		430		mA

### ME6213C33

( $V_{\text{IN}} = V_{\text{OUT}} + 1\text{V}$ ,  $V_{\text{CE}} = V_{\text{IN}}$ ,  $C_{\text{IN}} = C_{\text{OUT}} = 1\mu\text{F}$ ,  $T_a = 25^\circ\text{C}$ , unless otherwise noted)

Parameter	Symbol	Conditions	Min.	Typ.	Max.	Units
Output Voltage	$V_{\text{OUT}}(\text{E})$ (Note 2)	$I_{\text{OUT}} = 30\text{mA}$ , $V_{\text{IN}} = V_{\text{OUT}} + 1\text{V}$	X 0.99	$V_{\text{OUT}}(\text{T})$ (Note 1)	X 1.01	V
Input Voltage	$V_{\text{IN}}$		3.3		6	V
Maximum Output Current	$I_{\text{OUTMAX}}$	$V_{\text{IN}} = V_{\text{OUT}} + 1\text{V}$		350		mA
Load Regulation	$\Delta V_{\text{OUT}}$	$V_{\text{IN}} = V_{\text{OUT}} + 1\text{V}$ , $1\text{mA} \leq I_{\text{OUT}} \leq 100\text{mA}$		4		mV
Dropout Voltage (Note 1)	$V_{\text{DIF1}}$	$I_{\text{OUT}} = 100\text{mA}$		100		mV
	$V_{\text{DIF2}}$	$I_{\text{OUT}} = 200\text{mA}$		200		mV
Supply Current	$I_{\text{SS}}$	$V_{\text{IN}} = V_{\text{OUT}} + 1\text{V}$		7.5		$\mu\text{A}$
Stand-by Current	$I_{\text{CEL}}$	$V_{\text{CE}} = 0\text{V}$		0.02		$\mu\text{A}$
Line Regulation	$\Delta V_{\text{OUT}}$	$I_{\text{OUT}} = 30\text{mA}$ $V_{\text{OUT}} + 1\text{V} \leq V_{\text{IN}} \leq 6\text{V}$		4		mV
CE "High" Voltage	$V_{\text{CEH}}$	Start up	1.0			V
CE "Low" Voltage	$V_{\text{CEL}}$	Shut down			0.5	V
Short-circuit Current	$I_{\text{SHORT}}$	$V_{\text{IN}} = V_{\text{OUT}} + 1\text{V}$ , $V_{\text{CE}} = V_{\text{IN}}$ , $V_{\text{OUT}} = 0\text{V}$		45		mA
Over Current Protection	$I_{\text{limit}}$	$V_{\text{IN}} = 4.3\text{V}$		440		mA

Note :

- $V_{\text{OUT}}(\text{T})$  : Specified Output Voltage
- $V_{\text{OUT}}(\text{E})$  : Effective Output Voltage ( i.e. The output voltage when " $V_{\text{OUT}}(\text{T}) + 1.0\text{V}$ " is provided at the  $V_{\text{in}}$  pin while maintaining a certain  $I_{\text{out}}$  value.)
- $V_{\text{DIF}}$ :  $V_{\text{IN1}} - V_{\text{OUT}}(\text{E})'$   
 $V_{\text{IN1}}$  : The input voltage when  $V_{\text{OUT}}(\text{E})'$  appears as input voltage is gradually decreased.  
 $V_{\text{OUT}}(\text{E})'$  = A voltage equal to 98% of the output voltage whenever an amply stabilized  $I_{\text{out}} \{V_{\text{OUT}}(\text{T}) + 1.0\text{V}\}$  is input.

## Type Characteristics

(1) Output Voltage VS. Output Current ( $V_{IN}=V_{OUT}+1$ ,  $T_a = 25\text{ }^\circ\text{C}$ )

ME6213C28

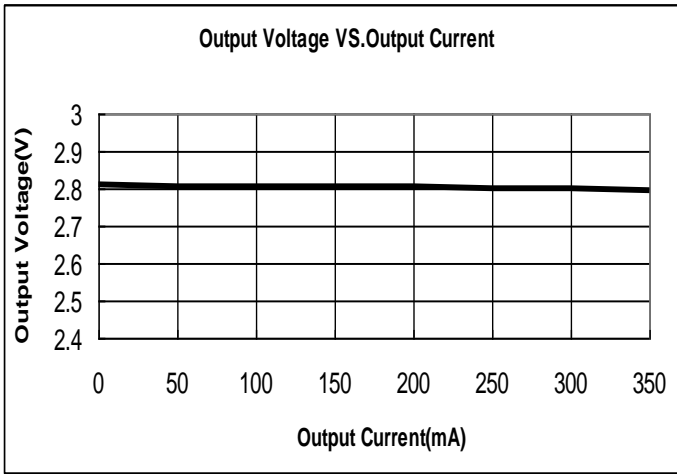

ME6213C33

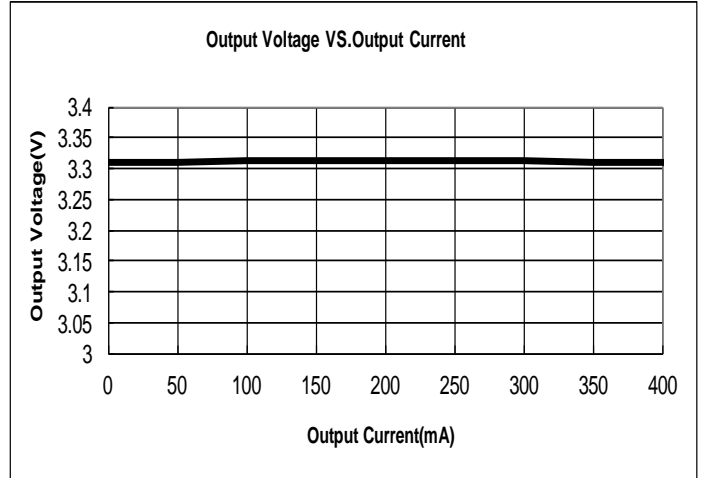

(2) Output Voltage VS. Input Voltage ( $T_a = 25\text{ }^\circ\text{C}$ )

ME6213C28

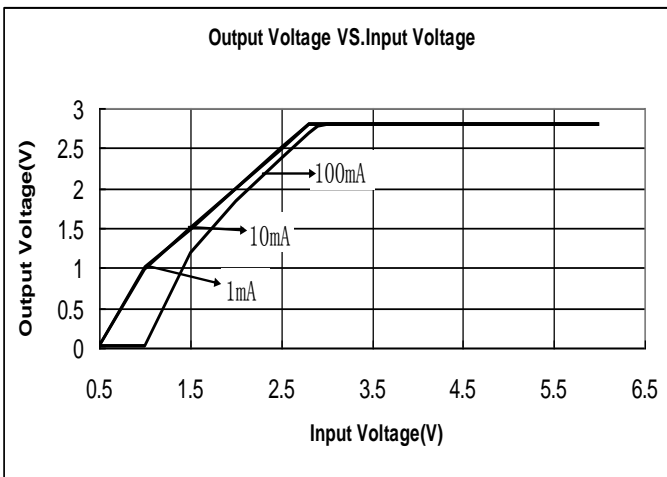

ME6213C33

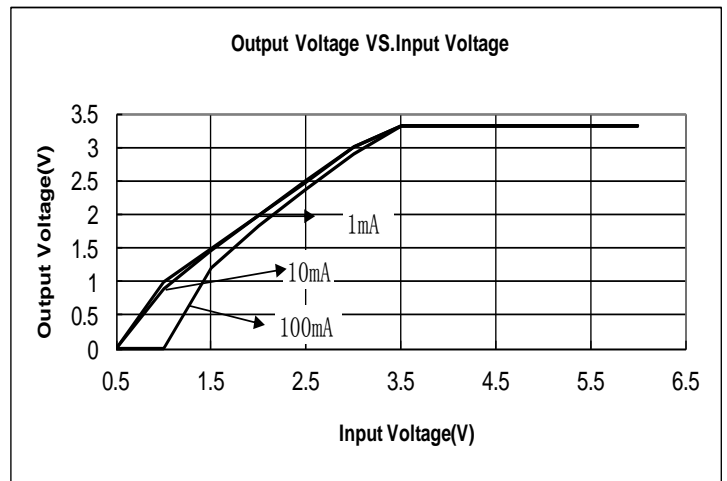

(3) Dropout Voltage VS. Output Current ( $V_{IN}=V_{OUT}+1V$ ,  $T_a = 25\text{ }^\circ\text{C}$ )

ME6213C28

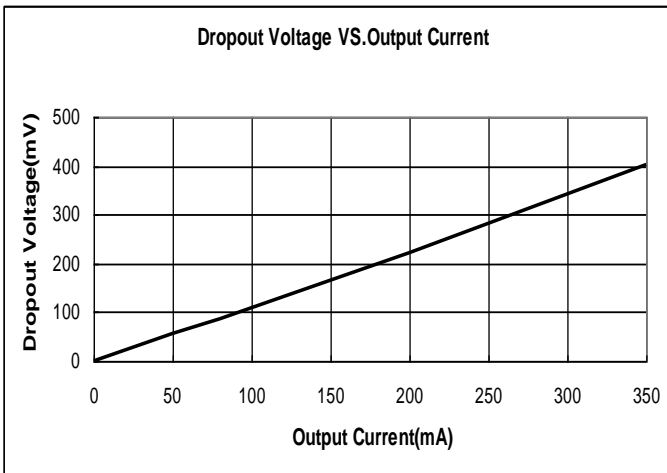

ME6213C33

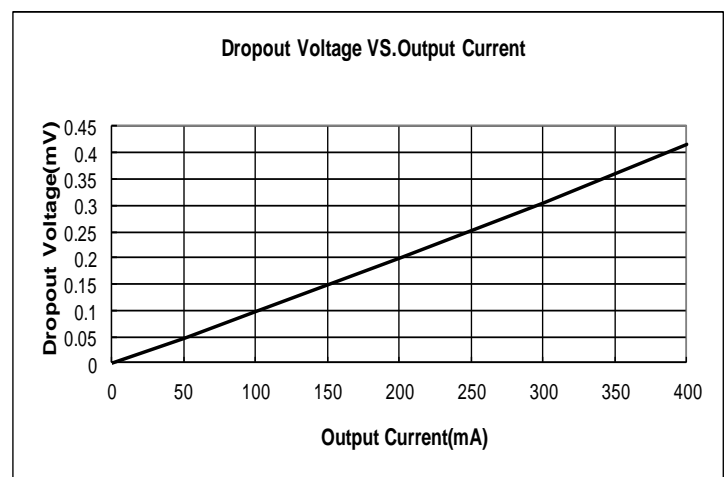

(4) Supply Current VS. Input Voltage ( $T_a = 25\text{ }^\circ\text{C}$ )

ME6213C28

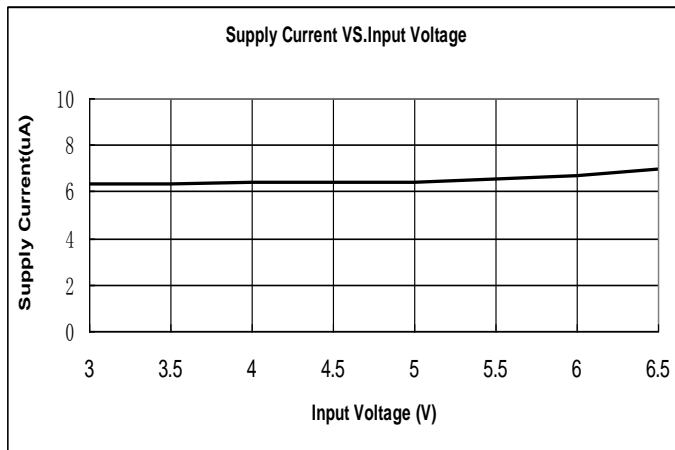

ME6213C33

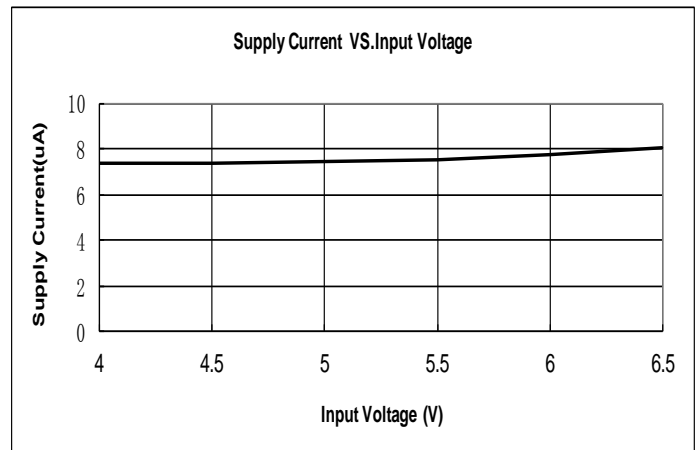

(5) Output Voltage VS. Temperature ( $V_{IN}=V_{OUT}+1V$ ,  $I_{OUT}=10mA$ )

ME6213C28

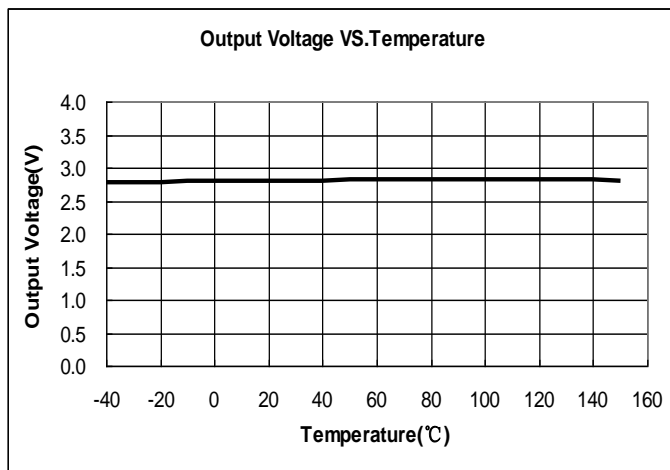

ME6213C33

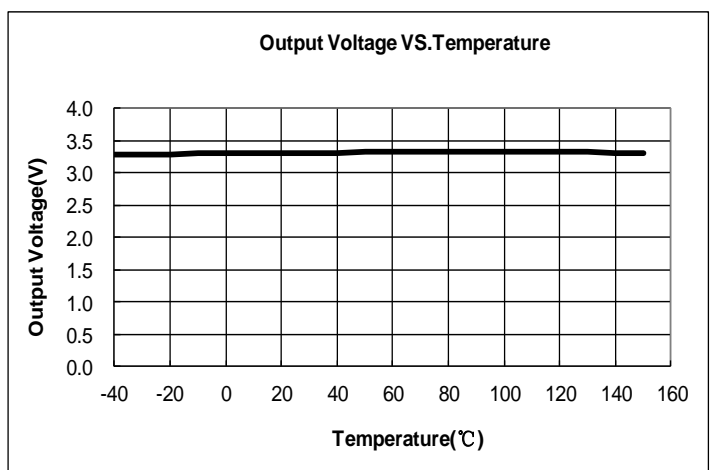

## Packaging Information

- SOT23-5L

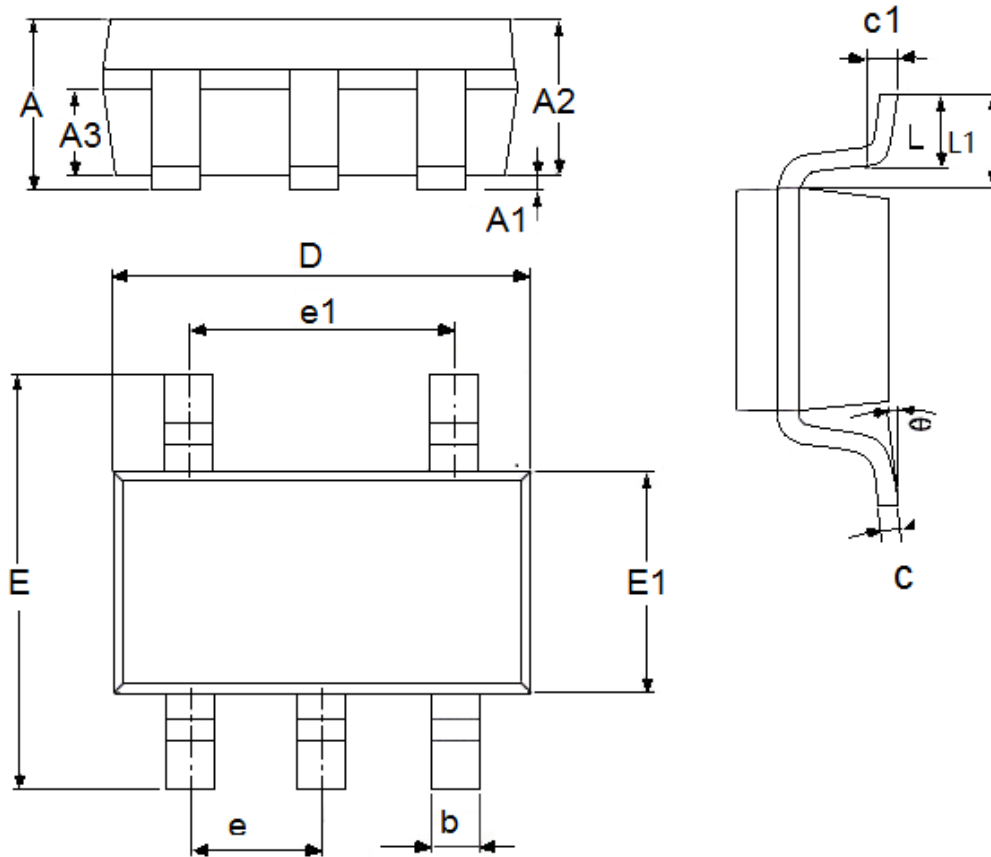

DIM	Millimeters		Inches	
	Min	Max	Min	Max
A	1.05	1.45	0.0413	0.0571
A1	0	0.15	0.0000	0.0059
A2	0.9	1.3	0.0354	0.0512
A3	0.6	0.7	0.0236	0.0276
b	0.25	0.5	0.0098	0.0197
c	0.1	0.23	0.0039	0.0091
D	2.82	3.05	0.1110	0.1201
e1	1.9(TYP)		0.0748(TYP)	
E	2.6	3.05	0.1024	0.1201
E1	1.5	1.75	0.0512	0.0689
e	0.95(TYP)		0.0374(TYP)	
L	0.25	0.6	0.0098	0.0236
L1	0.59(TYP)		0.0232(TYP)	
θ	0	8°	0.0000	8°
c1	0.2(TYP)		0.0079(TYP)	

● DFN2x2-6L

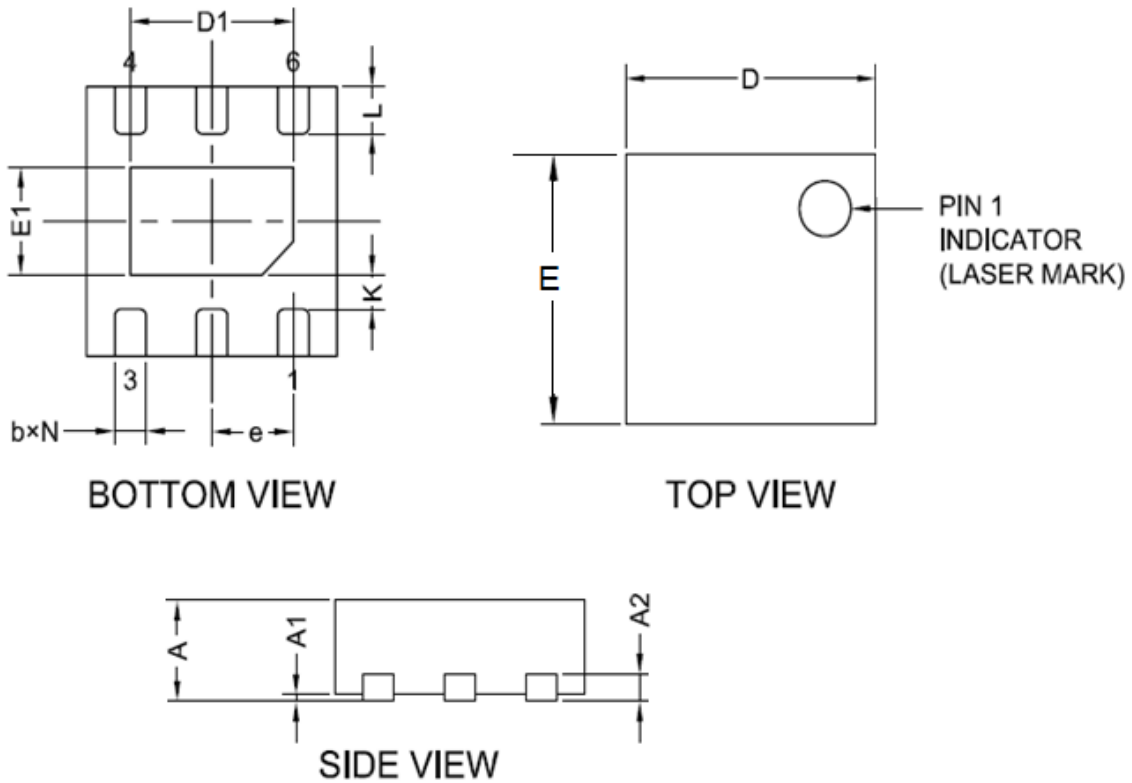

DIM	Millimeters		Inches	
	Min	Max	Min	Max
A	0.7	0.8	0.0276	0.0315
A1	0	0.05	0	0.002
A2	0.203(TYP)		0.008(TYP)	
b	0.2	0.35	0.0078	0.0138
D	1.9	2.1	0.0748	0.0827
E	1.9	2.1	0.0748	0.0827
E1	0.5	0.9	0.0197	0.0354
e	0.65(TYP)		0.0256(TYP)	
L	0.25	0.426	0.0098	0.0168
K	0.2	—	0.0079	—
D1	1	1.45	0.0393	0.0571

- The information described herein is subject to change without notice.
- Nanjing Micro One Electronics Inc is not responsible for any problems caused by circuits or diagrams described herein whose related industrial properties, patents, or other rights belong to third parties. The application circuit examples explain typical applications of the products, and do not guarantee the success of any specific mass-production design.
- Use of the information described herein for other purposes and/or reproduction or copying without the express permission of Nanjing Micro One Electronics Inc is strictly prohibited.
- The products described herein cannot be used as part of any device or equipment affecting the human body, such as exercise equipment, medical equipment, security systems, gas equipment, or any apparatus installed in airplanes and other vehicles, without prior written permission of Nanjing Micro One Electronics Inc.
- Although Nanjing Micro One Electronics Inc exerts the greatest possible effort to ensure high quality and reliability, the failure or malfunction of semiconductor products may occur. The user of these products should therefore give thorough consideration to safety design, including redundancy, fire-prevention measures, and malfunction prevention, to prevent any accidents, fires, or community damage that may ensue.