



Current Mode PWM Controller With Frequency Shuffling

General Description

ME8119 integrates a PWM controller and high voltage power MOSFET of 600V. ME8119 has the features of very low standby power (<100mW) when AC power above 220Vac. and cost effective offline flyback converter applications in 24W range. ME8119 offers complete protection coverage with automatic self-recovery feature including Cycle-by-Cycle current limiting (OCP), CS short protection, over load protection (OLP), and VDD under voltage lockout (UVLO) and latch feature including over temperature protection (OTP), over voltage (fixed or adjustable) protection(OVP). Excellent EMI performance is achieved with frequency shuffling technique together with soft switching control at the totem pole gate drive output. Tone energy at below 20KHz is minimized in the design and audio noise is eliminated during operation.

Typical Application

Offline AC/DC flyback converter for

- Switching AC/DC Power battery charge
- Digital cameras and camcorder adapter
- Set-top box power
- Auxiliary power supply for PC and server
- Open-frame SMPS

Features

- Power on Soft Start Reducing MOSFET V_{DS} Stress
- Frequency shuffling for EMI
- Audio Noise Free Operation
- Extended Burst Mode Control For Improved Efficiency and Minimum Standby Power Design
- Internal Synchronized Slope Compensation
- Fixed 65KHz Switching Frequency
- Good protection coverage with auto self-recovery
 - * VDD Under Voltage Lockout with Hysteresis (UVLO)
 - * Over Temperature Protection (OTP)
 - * Cycle-by-cycle over current threshold setting for constant output power limiting over universal input voltage range
 - * Overload Protection (OLP) with auto-recovery
 - * VDD Over voltage Protection(OVP)
 - * Adjustable OVP through external Zener
 - * CS floating protection with auto-recovery
 - * CS short protection with auto-recovery

Package

- 8-pin DIP8

Typical Application

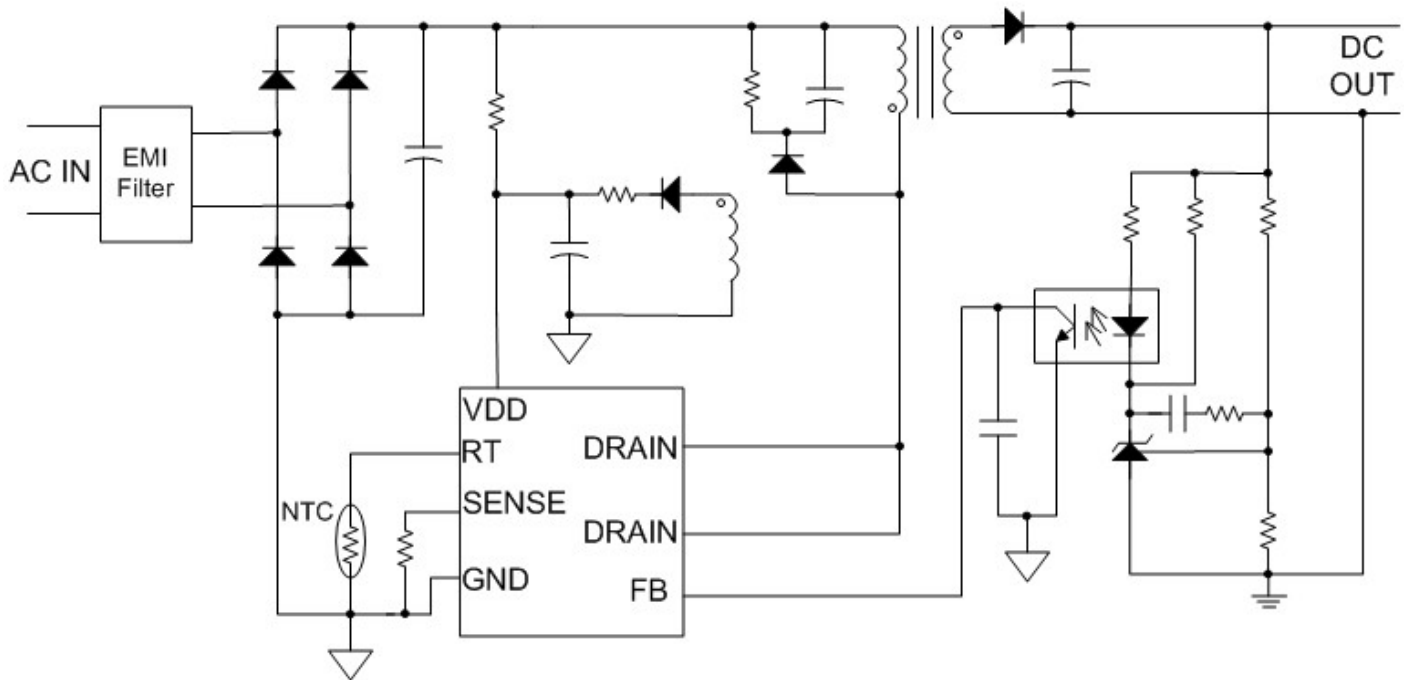

Selection Guide

ME8119XG

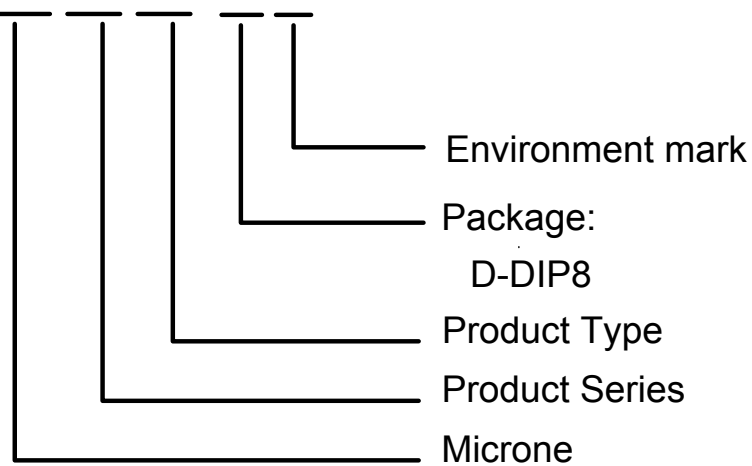

product series	product description
ME8119D8G	Built-in 600V mos, Package: DIP8

Pin Configuration

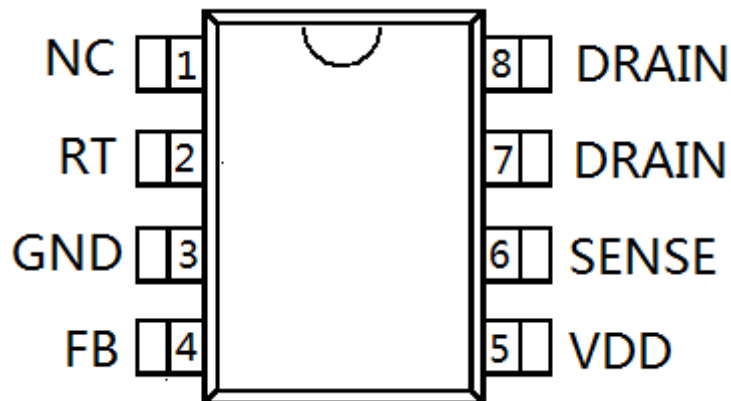

PIN Assignments

Pin Num.	Symbol	Description
1	NC	
2	RT	Dual function PIN. Either connected through a NTC resistor to ground for over temperature shutdown/latch control or connected through Zener to VDD for adjustable over voltage protection.
3	GND	Ground
4	FB	Voltage feedback pin, by connecting a photo-coupler to control the duty cycle
5	VDD	Chip DC power supply pin.
6	SENSE	Current sense input pin. Connected to MOSFET current sensing resistor node.
7,8	DRAIN	Drain of internal HV MOS

Block Diagram

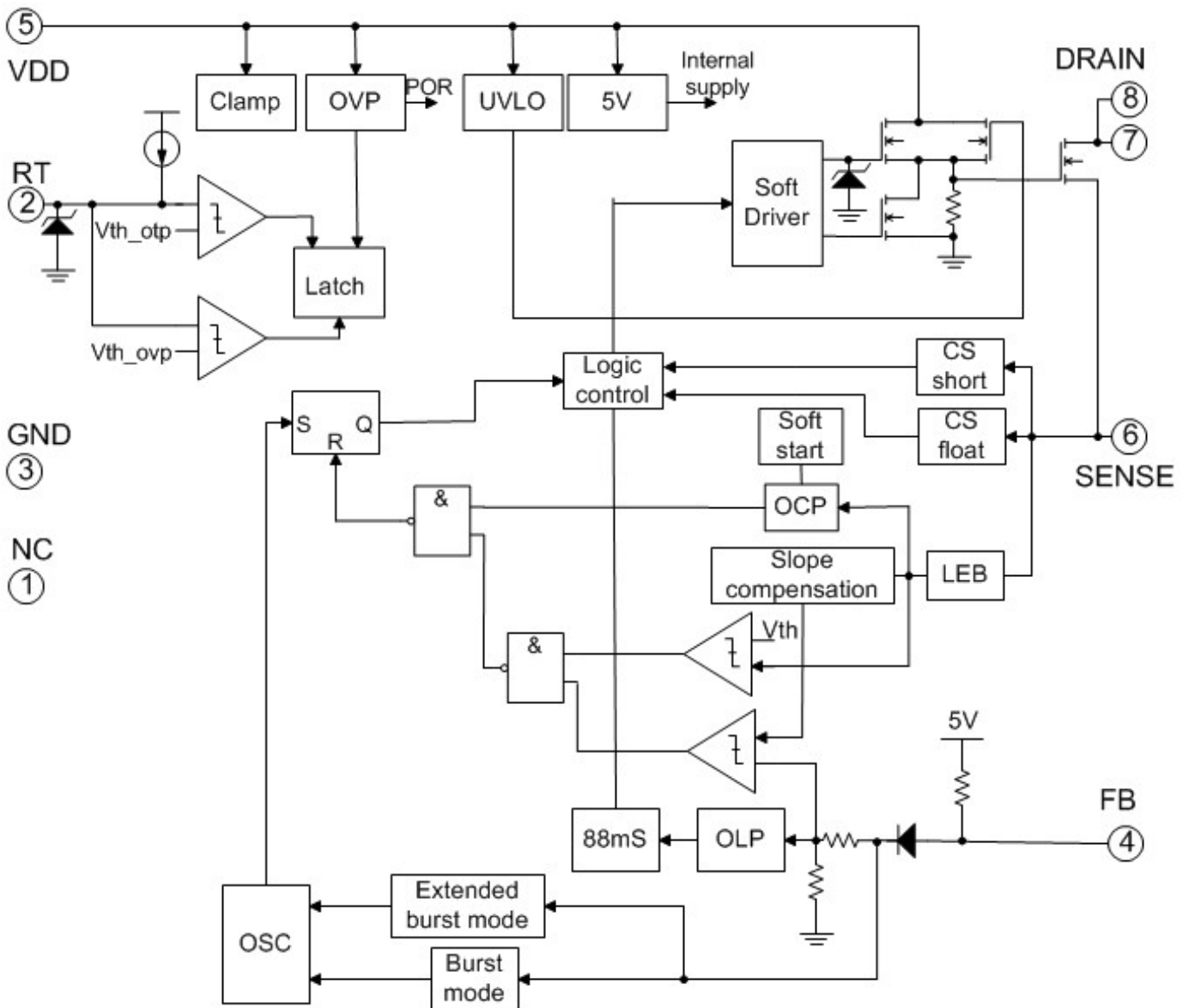

Absolute Maximum Ratings

Parameter	Range	Unit
VDD/VIN DC Supply Voltage	40	V
Drain Voltage	-0.3~600	V
VDD Zener Clamp Voltage ^{Note}	VDD_Clamp+0.1V	V
VDD DC Clamp Continuous Current	10	mA
V _{FB} , V _{SENSE} , V _{RT} (Voltage at FB, SENSE, RT to GND)	-0.3 to 7	V
Min/Max Operating Junction Temperature T _J	-20 to 85	°C
Min/Max Storage Temperature T _{stg}	-55 to 150	°C

Caution: The absolute maximum ratings are rated values exceeding which the product could suffer physical damage.

These values must therefore not be exceeded under any conditions.

Note: VDD_Clamp has a nominal value of 32V.

Recommended Operating Condition

Parameter	Range	Unit
VDD Supply Voltage	10 to 30	V
T _A Operating Ambient Temperature	-20 to 85	°C

Electrical Characteristics (T_A = 25°C, VDD=16V, if not otherwise noted)

Symbol	Parameter	Test Conditions	Min	Typ.	Max	Unit
Supply Voltage (VDD)						
I _{Startup}	VDD Start up Current	VDD=11V, Measure leakage current into VDD	-	2	20	μA
I _{VDD_Operation}	Operation Current	V _{FB} =3V	-	1.8	3	mA
UVLO _{ON}	VDD Under Voltage Lockout Enter		8	9	10	V
UVLO _{OFF}	VDD Under Voltage Lockout Exit (Recovery)		13	14	15.5	V
V _{PULL-UP}	Pull-up PMOS active		-	13	-	V
V _{DD_Clamp}		I _{VDD} = 10 mA	30	32	34	V
OVP _{ON}	VDD Over voltage protection enter	CS=0V,FB=3V Ramp up VDD until gate clock is off	24	26	28	V
Feedback Input Section(FB Pin)						
AV _{CS}	PWM Input Gain $\Delta V_{FB} / \Delta V_{CS}$		-	2	-	V/V
Maximum duty cycle	Max duty cycle	V _{DD} =16V, V _{FB} =3V, V _{CS} =0V	75	80	85	%
V _{FB_Open}	V _{FB} Open Loop Voltage		3.9	4.2	-	V
I _{FB_Short}	FB pin short circuit current	Short FB pin to GND, measure current	-	0.3	-	mA
V _{REF_GREEN}	The threshold enter green mode		-	1.4	-	V
V _{REF_BURST_H}	The threshold exit burst mode		-	0.675	-	V
V _{REF_BURST_L}	The threshold enter burst mode		-	0.575	-	V
V _{TH_PL}	Power Limiting FB Threshold Voltage		-	3.7	-	V
T _{D_PL}	Power limiting Debounce Time		80	88	96	mS
Z _{FB_IN}	Input Impedance		-	4	-	KΩ
Current Sense Input(Sense Pin)						
Soft start time			-	4	-	mS
T _{blanking}	Leading edge blanking time		-	220	-	nS

Z _{SENSE_IN}	Input Impedance		-	40	-	KΩ
T _{D_OC}	Over Current Detection and Control Delay	From over current occurs till the gate drive output start to turn off	-	120	-	nS
V _{TH_OC}	Internal current limiting threshold voltage	FB=3.3V	-	0.875	-	V
V _{OCP_CLAMPER}	CS voltage clamber		-	0.95	-	V
Oscillator						
F _{OSC}	Normal Oscillation Frequency	VDD=16V,FB=3V,CS=0V	60	65	70	KHz
Δf _{OSC}	Frequency jittering		-	±4	-	%
Δf _{Temp}	Frequency Temperature Stability	-20°C to 100 °C	-	1	-	%
F _{shuffling}	Shuffling frequency		-	32	-	Hz
Δf _{VDD}	Frequency Voltage Stability		-	1	-	%
F _{Burst}	Burst Mode Base Frequency		-	22	-	KHz
MOSFET SECTION (DRAIN Pin)						
BV _{dss}	Drain-Source Voltage	V _{gs} =0	600	-	-	V
R _{on}	Static Drain-Source On-Resistance	V _{GS} =10V, I _d =1.0A	-	-	2.5	Ω
I _D	Continuous drain current		-	-	4	A
Duty	Maximum duty cycle		75	80	85	%
Over Temperature Protection						
I _{RT}	Output current of RT pin		95	100	105	μA
V _{OTP}	Threshold voltage for OTP		0.95	1	1.05	V
V _{OTP_FL}	Float voltage at RT pin		-	2.3	-	V
T _{D_OTP}	OTP De-bounce time		-	32	-	Cycle
V _{RT_OVP}	RT Pin open voltage		-	4	-	V

Operation Description

The ME8119 is a low power off-line SMPS Switcher optimized for off-line flyback converter applications in 24W power range. The 'Extended burst mode' control greatly reduces the standby power consumption and helps the design easily to meet the international power conservation requirements.

●Startup Current and Start up Control

Startup current of ME8119 is designed to be very low so that VDD could be charged up above UVLO threshold level and device starts up quickly. A large value startup resistor can therefore be used to minimize the power loss yet provides reliable startup in application. For a typical AC/DC adaptor with universal input range design, a 2 MΩ, 1/8 W startup resistor could be used together with a VDD capacitor to provide a fast startup and low power dissipation design solution.

●Operating Current

The Operating current of ME8119 is low at 1.8mA. Good efficiency is achieved with ME8119 low operating current together with extended burst mode control features.

●Frequency shuffling for EMI improvement

The frequency Shuffling/jittering (switching frequency modulation) is implemented in ME8119. The oscillation frequency is modulated with a random source so that the tone energy is spread out. The spread spectrum minimizes the conduction band EMI and therefore reduces system design challenge.

●Extended Burst Mode Operation

At zero load or light load condition, majority of the power dissipation in a switching mode power supply is from switching loss on the MOSFET transistor, the core loss of the transformer and the loss on the snubber circuit. The magnitude of power loss is in proportion to the switching frequency. Lower switching frequency leads to the reduction on the power loss and thus conserves the energy.

The switching frequency is internally adjusted at no load or light load condition. The switch frequency reduces at light/no load condition to improve the conversion efficiency. At light load or no load condition, the FB input drops below burst mode threshold level and device enters Burst Mode control. The Gate drive output switches only when VDD voltage drops below a preset level and FB input is active to output an on state. Otherwise the gate drive remains at off state to minimize the switching loss and reduces the standby power consumption to the greatest extend. The nature of high frequency switching also reduces the audio noise at any loading conditions.

●Oscillator Operation

The switching frequency of ME8119 is internally fixed at 65KHz. No external frequency setting components are required for PCB design simplification.

●Current Sensing and Leading Edge Blanking

Cycle-by-Cycle current limiting is offered in ME8119 current mode PWM control. The switch current is detected by a sense resistor into the sense pin. Each time the power MOSFET is switched on, a turn-on spike will inevitably occur at the sense resistor. To avoid fault trigger, a 220ns leading-edge blanking time is built in. Conventional RC filtering can therefore be omitted. During this blanking period, the current-limit comparator is disabled and cannot switch off the gate driver.

●Internal Synchronized Slope Compensation

Built-in slope compensation circuit adds voltage ramp onto the current sense input voltage for PWM generation. This greatly improves the close loop stability at CCM and prevents the sub-harmonic oscillation and thus reduces the output ripple voltage.

●Over Temperature Protection

A NTC resistor in series with a regular resistor should connect between RT and GND for temperature sensing and protection. NTC resistor value becomes lower when the ambient temperature rises. With the fixed internal current I_{RT} flowing through the resistors, the voltage at RT pin becomes lower at high temperature. The internal OTP circuit is triggered and shutdown the MOSFET when the sensed input voltage is lower than V_{TH_OTP} .

●Protection Controls

Good power supply system reliability is achieved with its rich protection features including Cycle-by-Cycle current limiting (OCP), Over Load Protection (OLP), CS short protection, CS floating protection, and latch features including over temperature protection (OTP), fixed or adjustable over voltage protection (OVP), and Under Voltage Lockout on VDD (UVLO).

The OCP is line voltage compensated to achieve constant output power limit over the universal input voltage range.

At overload condition, When FB input exceeds power limit threshold value for more than T_{D_PL} , control circuit reacts to shut down the output power MOSFET. Similarly, control circuit reacts to shut down the switcher. Switcher restarts when VDD voltage drops below UVLO limit.

Typical performance characteristics

$V_{DD} = 16V$, $T_A = 25^\circ C$ condition applies if not otherwise noted

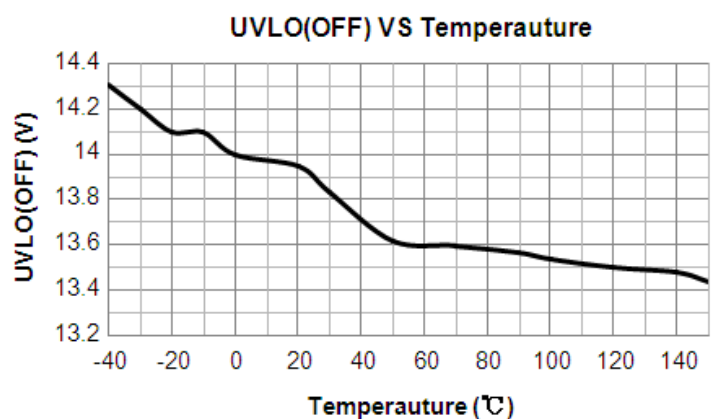
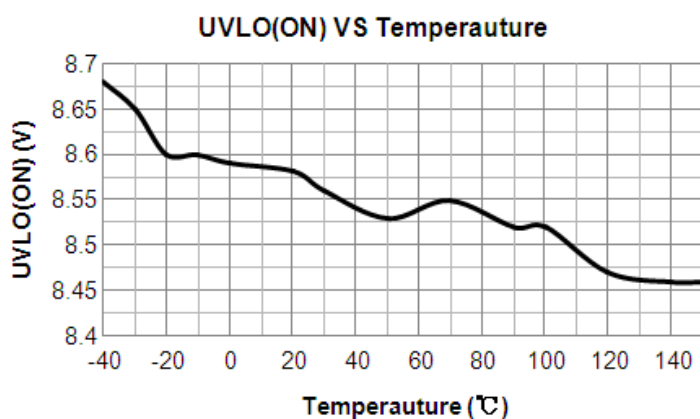
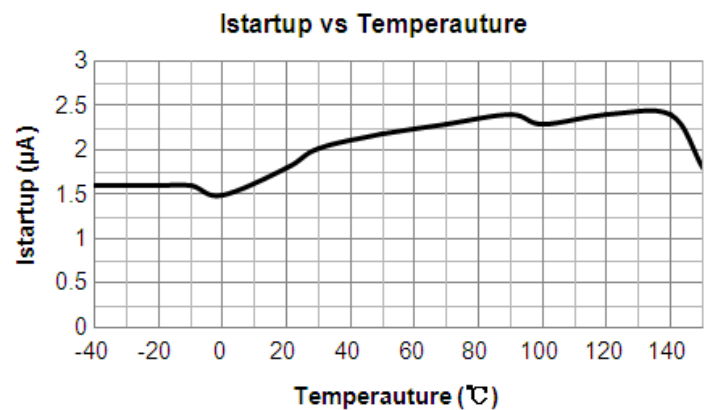
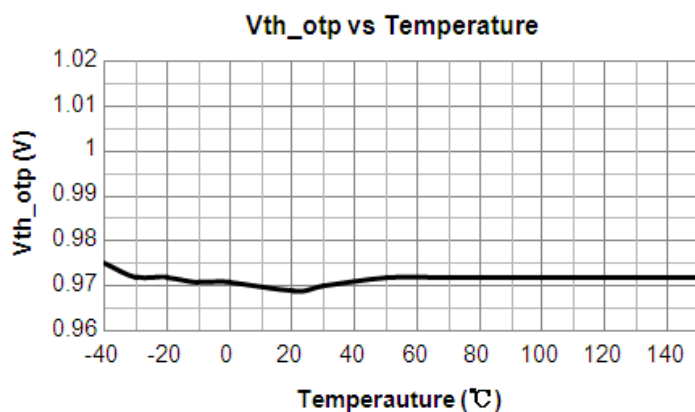

Packaging Information

● Package type:DIP8

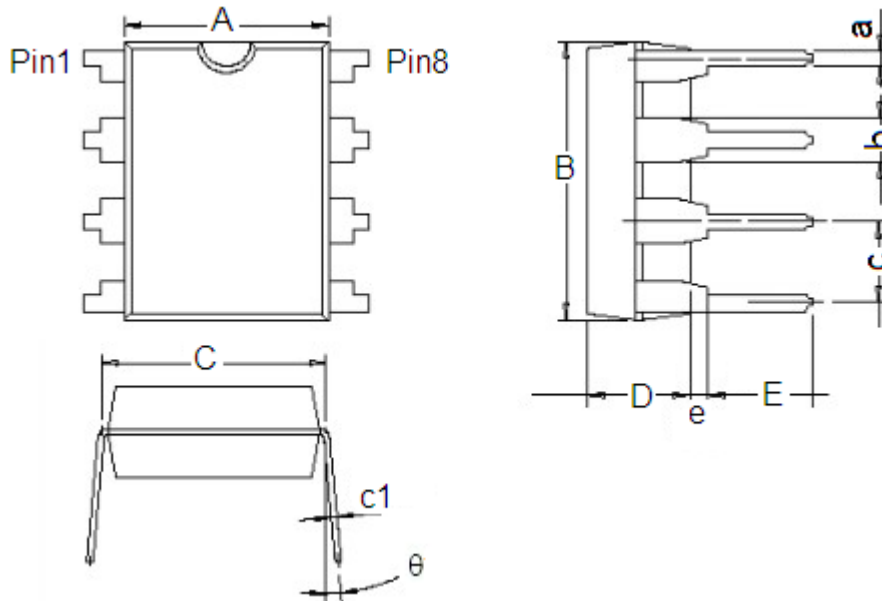

Character	Dimension (mm)		Dimension (Inches)	
	Min	Max	Min	Max
A	6.200	6.600	0.244	0.260
B	9.000	9.400	0.354	0.370
C	7.620(Typ.)		0.300(Typ.)	
D	3.200	3.600	0.126	0.142
E	3.000	3.600	0.118	0.142
a	0.360	0.560	0.014	0.022
b	1.524(Typ.)		0.060(Typ.)	
c	2.54(Typ.)		0.100(Typ.)	
c1	0.204	0.360	0.008	0.014
e	0.510(Min)		0.020(Min)	
θ	0°	15°	0°	15°

- The information described herein is subject to change without notice.
- Nanjing Micro One Electronics Inc is not responsible for any problems caused by circuits or diagrams described herein whose related industrial properties, patents, or other rights belong to third parties. The application circuit examples explain typical applications of the products, and do not guarantee the success of any specific mass-production design.
- Use of the information described herein for other purposes and/or reproduction or copying without the express permission of Nanjing Micro One Electronics Inc is strictly prohibited.
- The products described herein cannot be used as part of any device or equipment affecting the human body, such as exercise equipment, medical equipment, security systems, gas equipment, or any apparatus installed in airplanes and other vehicles, without prior written permission of Nanjing Micro One Electronics Inc.
- Although Nanjing Micro One Electronics Inc exerts the greatest possible effort to ensure high quality and reliability, the failure or malfunction of semiconductor products may occur. The user of these products should therefore give thorough consideration to safety design, including redundancy, fire-prevention measures, and malfunction prevention, to prevent any accidents, fires, or community damage that may ensue.