

Low-power off-line primary side regulation controller ME8302

General Description

The ME8302 is a high performance AC/DC power supply controller for battery charger and adapter applications. The device uses pulse frequency modulation (PFM) method to build discontinuous conduction mode(DCM) flyback power supplies.

The ME8302 provides accurate constant voltage, constant current(CV/CC) regulation without requiring an Opto-coupler and secondary control circuitry. It also eliminates the need of loop compensation circuitry while maintaining stability. The ME8302 achieves excellent regulation and high average efficiency, yet meets the requirement for no-load consumption less than 30mW.

The ME8302 has the built-in programmable cable voltage drop compensation function, which make it flexible to accommodate various cables with different gauges and lengths.

Applications

- Adapter/chargers for cell/cordless phones, PDAs, MP3 and other portable apparatus
- LED driver
- Standby and auxiliary power supplies

Features

- Primary side control for eliminating Opto-coupler and secondary CV/CC control circuitry
- 30mW no-load input power
- Programmable output cable voltage drop compensation
- Compensation for external component temperature variations
- Flyback topology in DCM operation
- Random frequency adjustment to reduce system EMI
- Built-in soft start
- over voltage protection
- Short circuit protection

Package

- 8-pin SOP8

Selection Guide

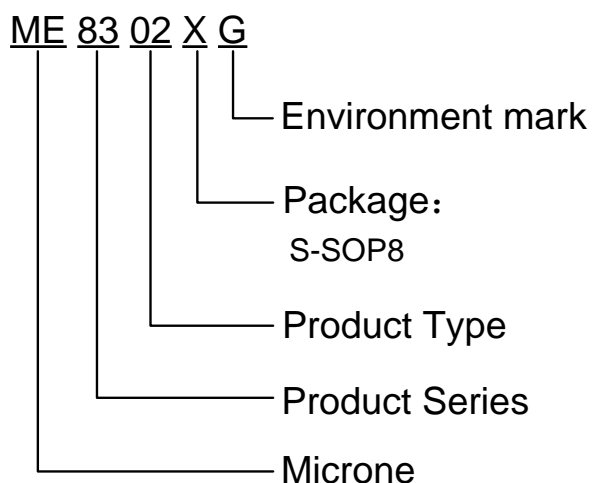

product series	product description
ME8302SG	Package: SOP8

Pin Configuration & Pin Assignment

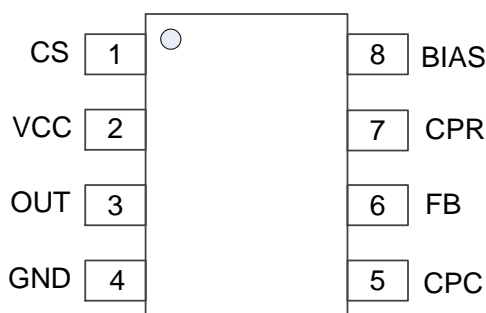

Pin Assignment

Pin Num.	Symbol	Function
1	CS	The primary current sense
2	VCC	Power Supply Pin
3	OUT	This pin drives the base of external power NPN switch
4	GND	Ground
5	CPC	This pin connects capacitor for output cable compensation
6	FB	The voltage feedback from the auxiliary winding
7	CPR	Connects a resistor to FB pin for adjustable output cable compensation
8	BIAS	This pin sets the bias current inside ME8302 with an external resistor to GND

Block Diagram

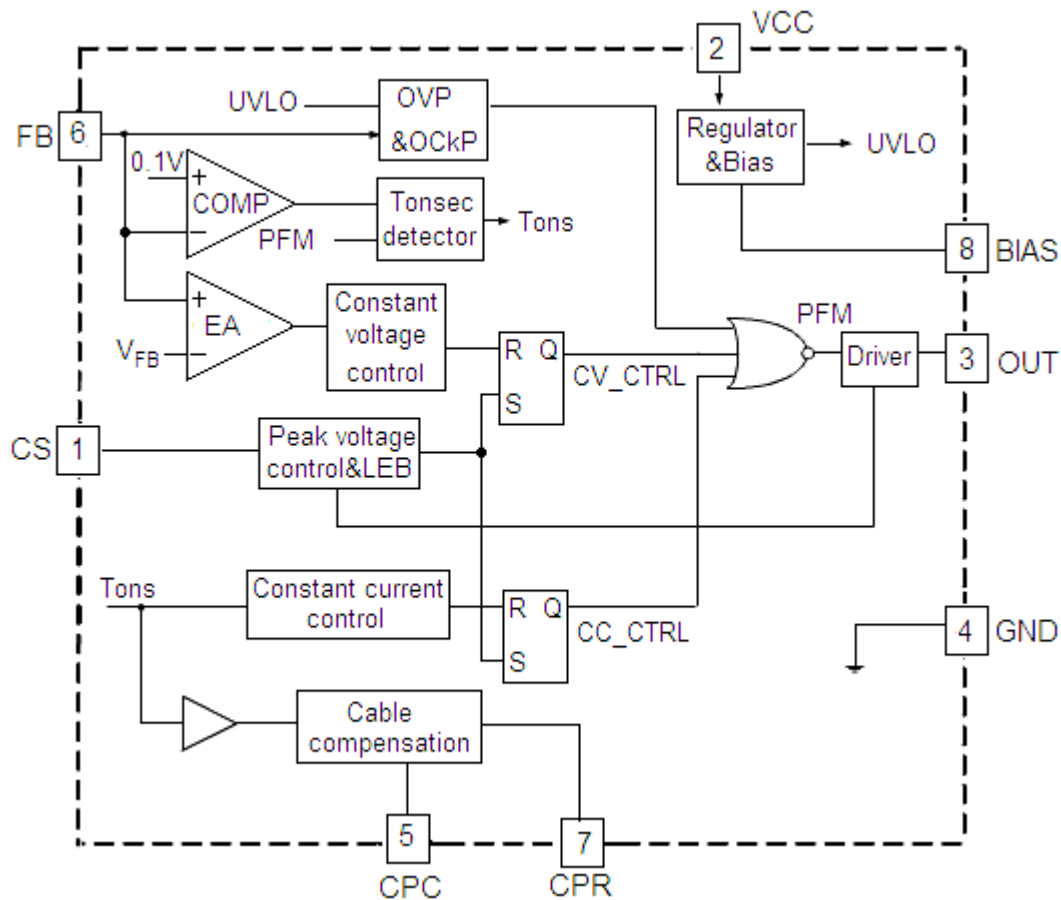

Absolute Maximum Ratings

Parameter	Rating	Unit
Voltage at VCC pin to GND:VCC	-0.3~36	V
Voltage at CS,OUT to GND	-0.3~7	V
FB input	-40~10	V
Output current at OUT	Internally limited	A
Thermal resistance junction-to-ambient	190	°C/W
ESD(Machine Model)	200	V
ESD(Human body Model)	2000	V
Operating junction temperature	150	°C
Storage Temperature	-65~+150	°C
Soldering temperature and time	+300 (Recommended 10S)	°C

Caution: The absolute maximum ratings are rated values exceeding which the product could suffer physical damage. These values must therefore not be exceeded under any conditions.

Electrical Characteristics (T_A =25 °C, V_{CC} =15V, unless otherwise noted.)

Item	Symbol	Test condition	Min	Typ.	Max	Unit	
UVLO section							
Start-up threshold	V _{TH(ST)}		16	17.5	19	V	
Minimal operating voltage	V _{OPR(min)}		6.8	8	9.2	V	
Reference voltage							
BIAS pin voltage	V _{BIAS}	R _{BIAS} =200KΩ after turn on	1.0	1.1	1.2	V	
Standby current section							
Start-up current	I _{ST}	V _{CC} = V _{TH(ST)} -0.5V,	-	-	0.6	μA	
Operating current	I _{CC(OPR)}	R _{BIAS} =200KΩ	-	390	480	μA	
Drive output section							
OUT maximum current	source	I _{OUT}	R _{BIAS} =200KΩ	28	36	44	mA
Current sense section							
Current sense threshold	V _{CS}		490	513	535	mV	
Pre-current sense	V _{CS(PRE)}		390	413	435	mV	
Leading edge blanking			-	500	-	ns	
Feedback input section							
Feedback pin input leakage current	I _{FB}	V _{FB} =4V	1.8	2.4	3.0	μA	
Feedback threshold	V _{FB}		3.97	4.03	4.09	V	
Enable turn-on voltage	V _{FB(EN)}		-2.0	-1.7	-1.4	V	
Output voltage compensation section							
CPR voltage	V _{CPR}	Dons(Tons/T):from 55% to	1.5	-	3.5	V	
CPR sink current	I _{CPR}		-	-	200	μA	
Protection section							
Over voltage protection	V _{FB(OVP)}		7	8	9	V	

Typical Performance Characteristics

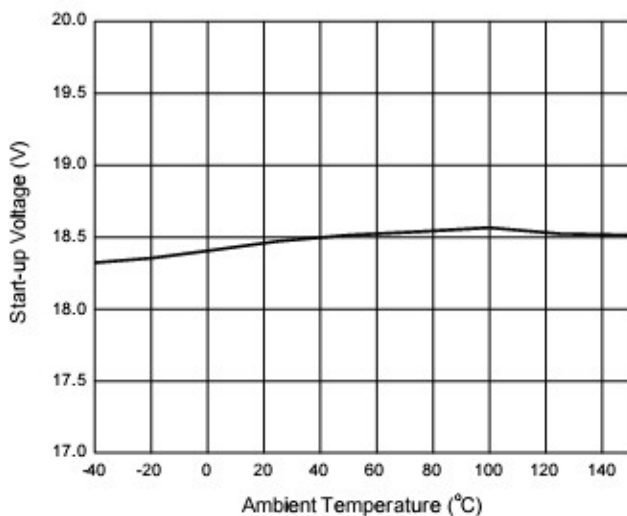

Figure 4. Start-up Voltage vs. Ambient Temperature

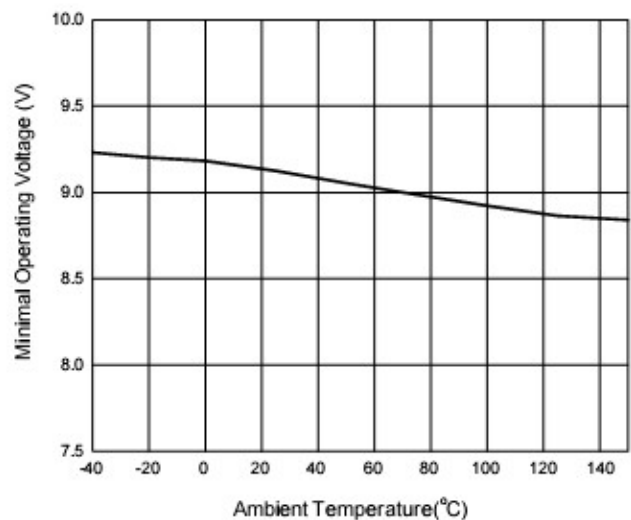

Figure 5. Minimal Operating Voltage vs. Ambient Temperature

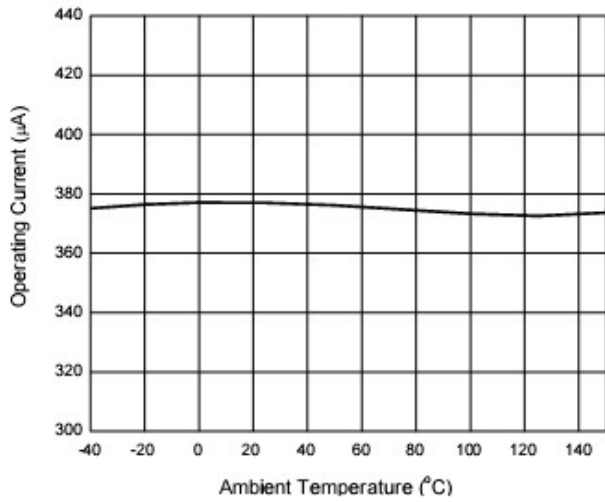

Figure 6. Operating Current vs. Ambient Temperature

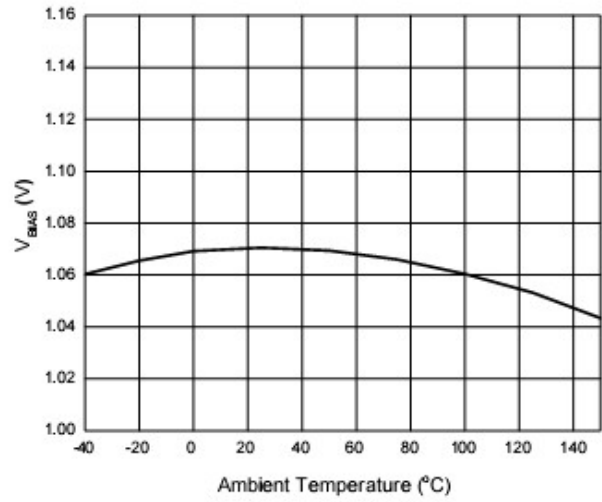

Figure 7. V_{BIAS} vs. Ambient Temperature

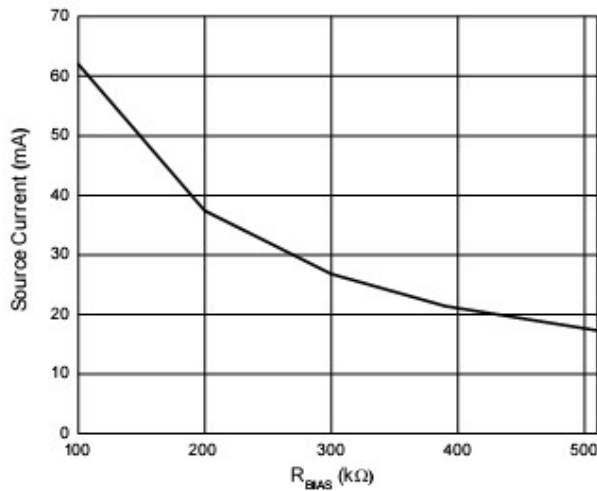

Figure 8. Source Current vs. R_{BIAS}

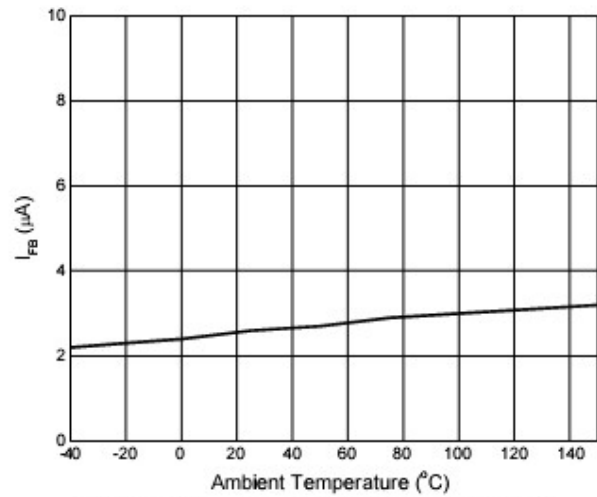

Figure 9. I_{FB} vs. Ambient Temperature

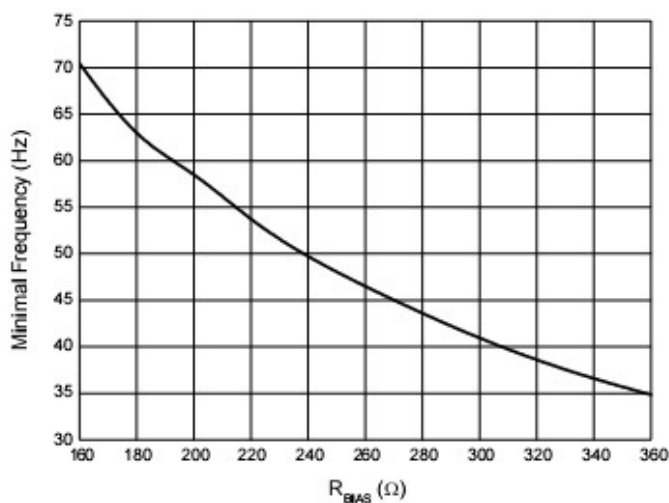
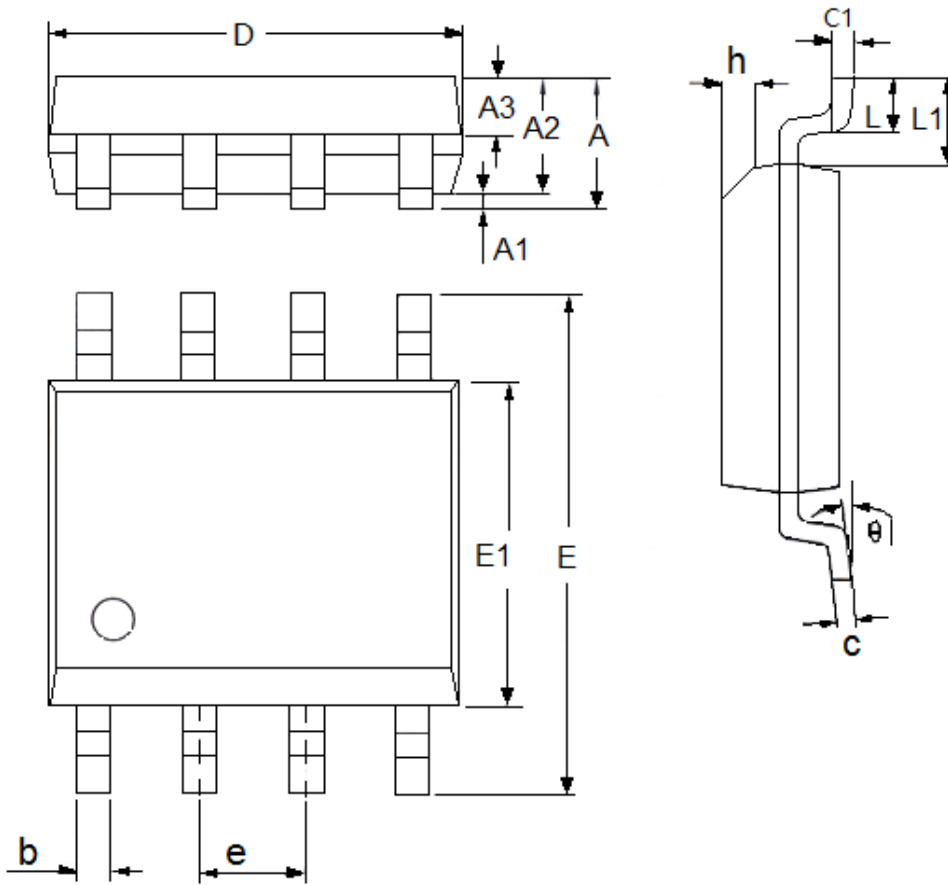

Figure 10. Minimal Frequency vs. R_{BIAS}

Packaging Information

- SOP8



DIM	Millimeters		Inches	
	Min	Max	Min	Max
A	1.3	1.8	0.0512	0.0709
A1	0.05	0.25	0.002	0.0098
A2	1.25	1.65	0.0492	0.065
A3	0.5	0.7	0.0197	0.0276
b	0.3	0.51	0.0118	0.0201
c	0.17	0.25	0.0067	0.0098
D	4.7	5.1	0.185	0.2008
E	5.8	6.2	0.2283	0.2441
E1	3.8	4	0.1496	0.1575
e	1.27(TYP)		0.05(TYP)	
h	0.25	0.5	0.0098	0.0197
L	0.4	1.27	0.0157	0.05
L1	1.04(TYP)		0.0409(TYP)	
theta	0	8°	0	8°
c1	0.25(TYP)		0.0098(TYP)	

- The information described herein is subject to change without notice.
- Nanjing Micro One Electronics Inc is not responsible for any problems caused by circuits or diagrams described herein whose related industrial properties, patents, or other rights belong to third parties. The application circuit examples explain typical applications of the products, and do not guarantee the success of any specific mass-production design.
- Use of the information described herein for other purposes and/or reproduction or copying without the express permission of Nanjing Micro One Electronics Inc is strictly prohibited.
- The products described herein cannot be used as part of any device or equipment affecting the human body, such as exercise equipment, medical equipment, security systems, gas equipment, or any apparatus installed in airplanes and other vehicles, without prior written permission of Nanjing Micro One Electronics Inc.
- Although Nanjing Micro One Electronics Inc exerts the greatest possible effort to ensure high quality and reliability, the failure or malfunction of semiconductor products may occur. The user of these products should therefore give thorough consideration to safety design, including redundancy, fire-prevention measures, and malfunction prevention, to prevent any accidents, fires, or community damage that may ensue.