



LOW-Power Off-line Primary Side Regulation Controller ME8305

General Description

The ME8305 is a high performance AC/DC power supply controller for battery charger and adapter applications. The device uses Pulse Frequency Modulation(PFM) method to build discontinuous conduction mode (DCM) flyback power supplies.

The ME8305 provides accurate constant voltage, constant current (CV/CC) regulation while removing the opto-coupler and secondary control circuitry. It also eliminates the need of loop compensation circuitry while maintaining stability. The ME8305 achieves excellent regulation and high average efficiency, yet meets the requirement for no-load consumption less than 30mW.

Typical Application

- Adapters/Chargers for Cell/Cordless Phones, PDAs, MP3 and Other Portable Apparatus
- LED Drivers
- Standby and Auxiliary Power Supplies

Features

- Set-in high-voltage power switch tube of 700V and few peripheral components.
- Primary Side Control for Rectangular Constant Current and Constant Voltage Output
- Sub-microampere Start-up Current
- 30mW No-load Input Power Feasible
- Tight CV Regulation Performance
- Eliminates Opto-coupler and Secondary CV/CC Control Circuitry
- Eliminates Control Loop Compensation Circuitry
- Flyback Topology in DCM Operation
- Random Frequency Modulation to Reduce System EMI
- Built-in Soft Start
- Open Feedback Protection
- Short Circuit Protection

Package

- 8-pin SOP8

Typical Application Circuit

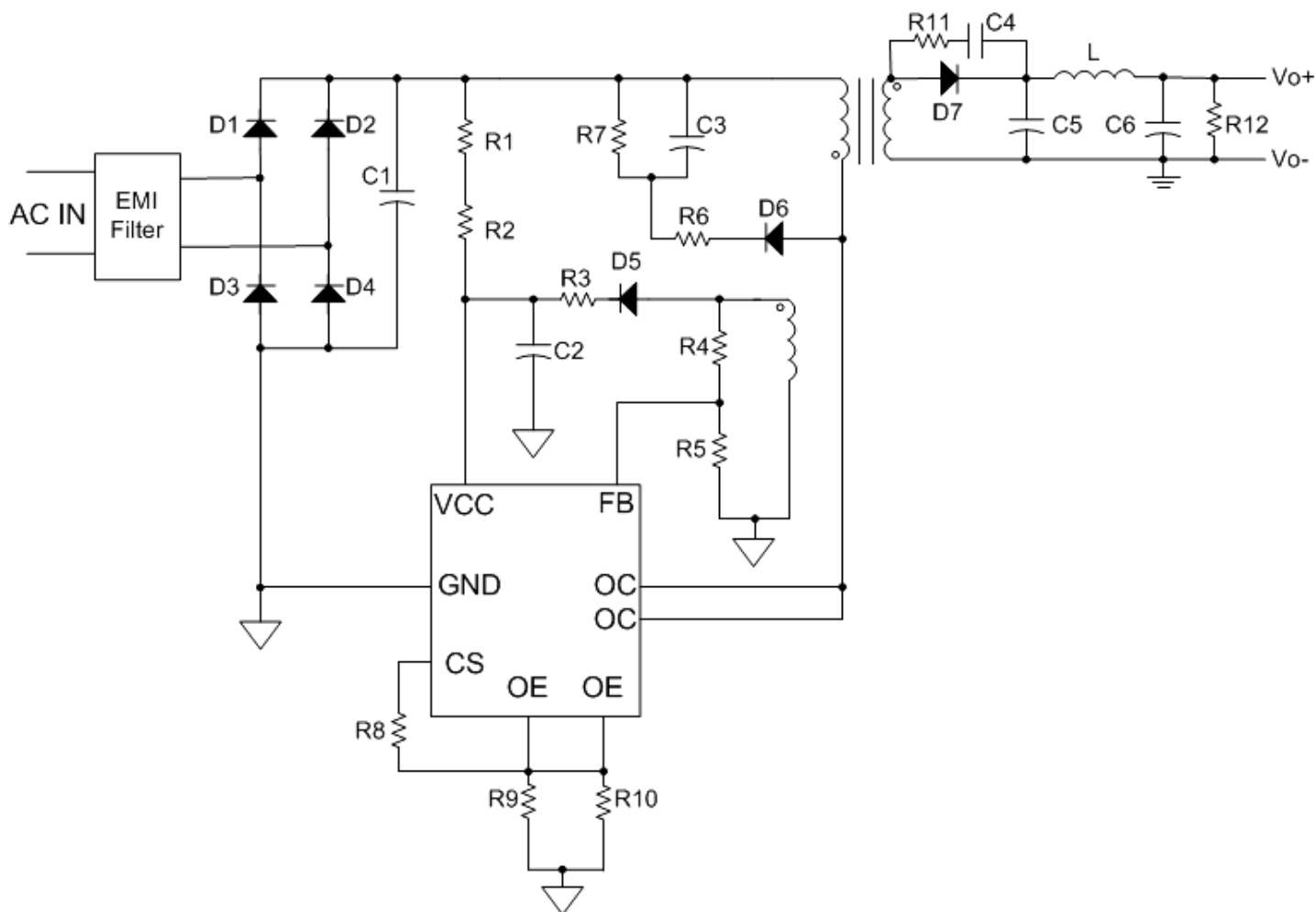

Selection Guide

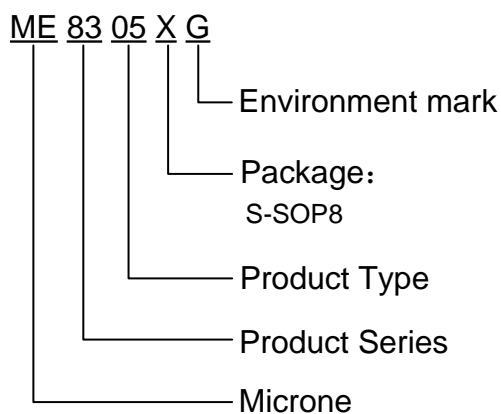

product series	product description
ME8305SG	Package: SOP8

Pin Configuration & Pin Assignment

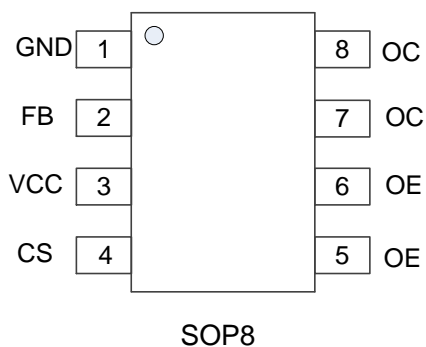

Pin Assignment

Pin Number	Pin Name	Function
1	GND	Ground
2	FB	The voltage feedback from the auxiliary winding
3	VCC	Supply voltage
4	CS	The primary current sense
5,6	OE	Emitter electrode of power tube
7,8	OC	Output pins, meet switching transformer

Block Diagram

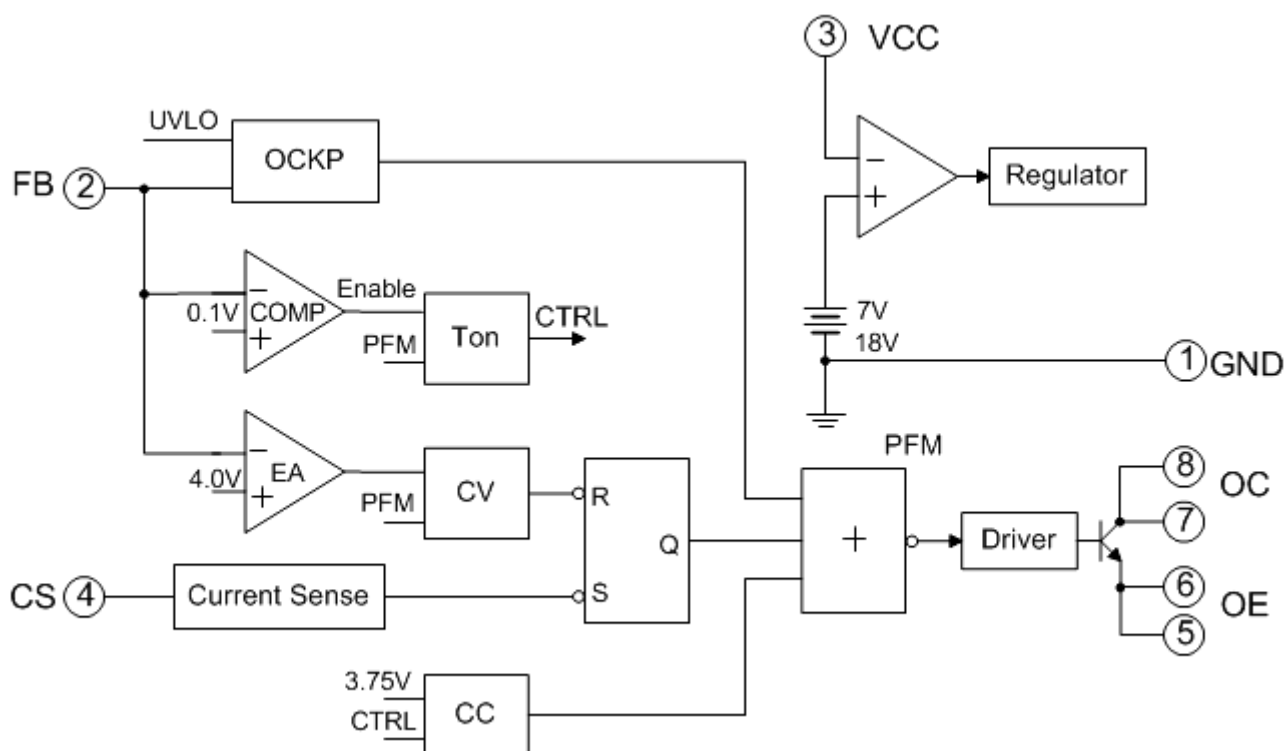

Absolute Maximum Ratings (Note)

Parameter	Value	Unit
Supply Voltage V_{CC}	-0.3 to 30	V
Voltage at CS to GND	-0.3 to 7	V
FB input	-40 to 10	V
Endurance voltage of OC collector	-0.3-700	V
Switching current of peak value	800	mA
Operating Junction Temperature	125	°C
Storage Temperature	-65 to 150	°C
Lead Temperature (Soldering, 10s)	300	°C
Thermal Resistance Junction-to-Ambient	250	°C/W
ESD (Machine Model)	200	V
ESD (Human Body Model)	2000	V

Note : The absolute maximum ratings are rated values exceeding which the product could suffer physical damage.

These values must therefore not be exceeded under any conditions.

Electrical Characteristics ($V_{CC}=20V$, $T_A=25^{\circ}C$, unless otherwise specified)

Parameter	Symbol	Conditions	Min	Typ.	Max	Unit
UVLO Section						
Start-up Threshold	$V_{TH(ST)}$		16	18	20	V
Minimal Operating Voltage	$V_{OPR(min)}$		5	7	9	V
Standby Current Section						
Start-up Current	I_{ST}	$V_{CC} = V_{TH(ST)} - 0.5V$,	-	-	0.5	μA
Operating Current	$I_{CC(OPR)}$	Static	-	200	300	μA
Current Sense Section						
Current Sense Threshold	V_{CS}		470	500	530	mV
Pre-Current Sense	$V_{CS(PRE)}$		370	400	430	mV
Leading Edge Blanking			-	500	-	ns
Feedback Input Section						
Feedback Pin Input Leakage Current	I_{FB}	$V_{FB}=4V$	2.0	2.5	3.1	μA
Feedback Threshold Voltage	V_{FB}		3.89	3.95	4.01	V
Output						
Maximum pressure resistance of switching tube	$V_{OC(max)}$	$I_{OC}=1mA, I_E=0$	700	-	-	V
on-saturation pressure drop	$V_{CE(sat)}$	$I_{OC}=600mA$	-	-	1	V
Output limit current		$T_j=0-100^{\circ}C$	465	500	535	mA

Type Characteristics

Vstart VS. Temperature

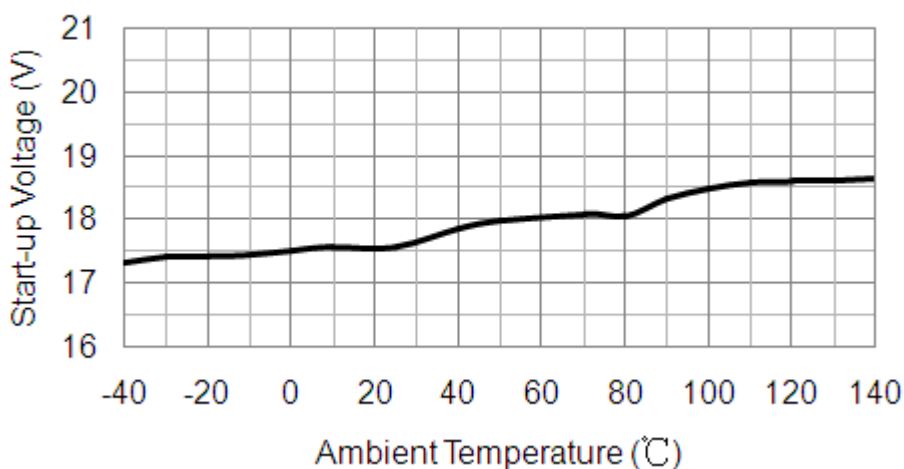

Vopermin VS. Temperature

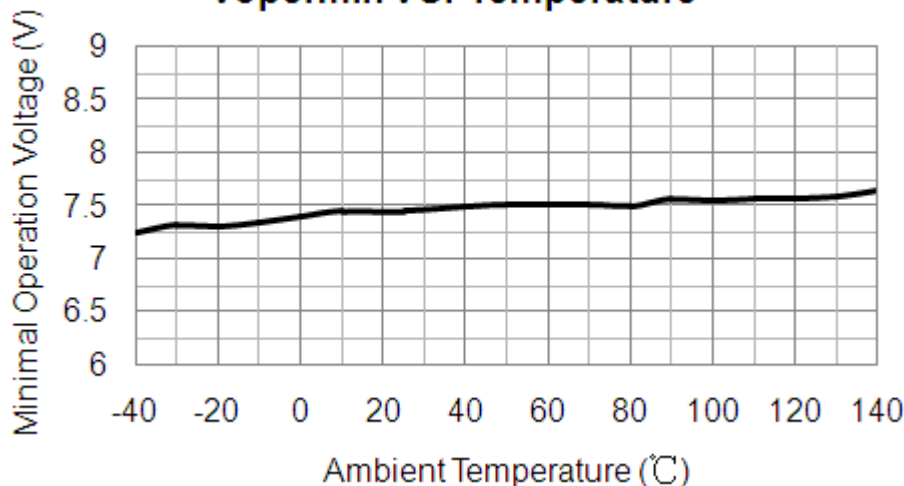

Ioper VS. Temperature

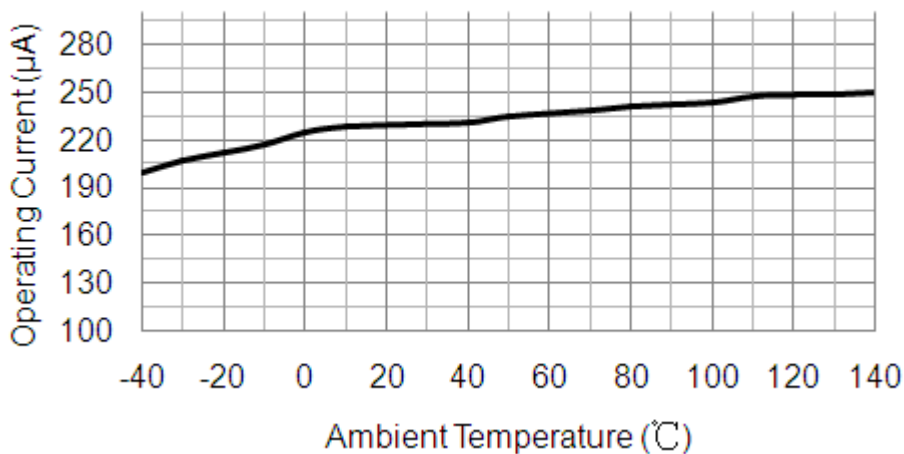

Packaging Information

● SOP8

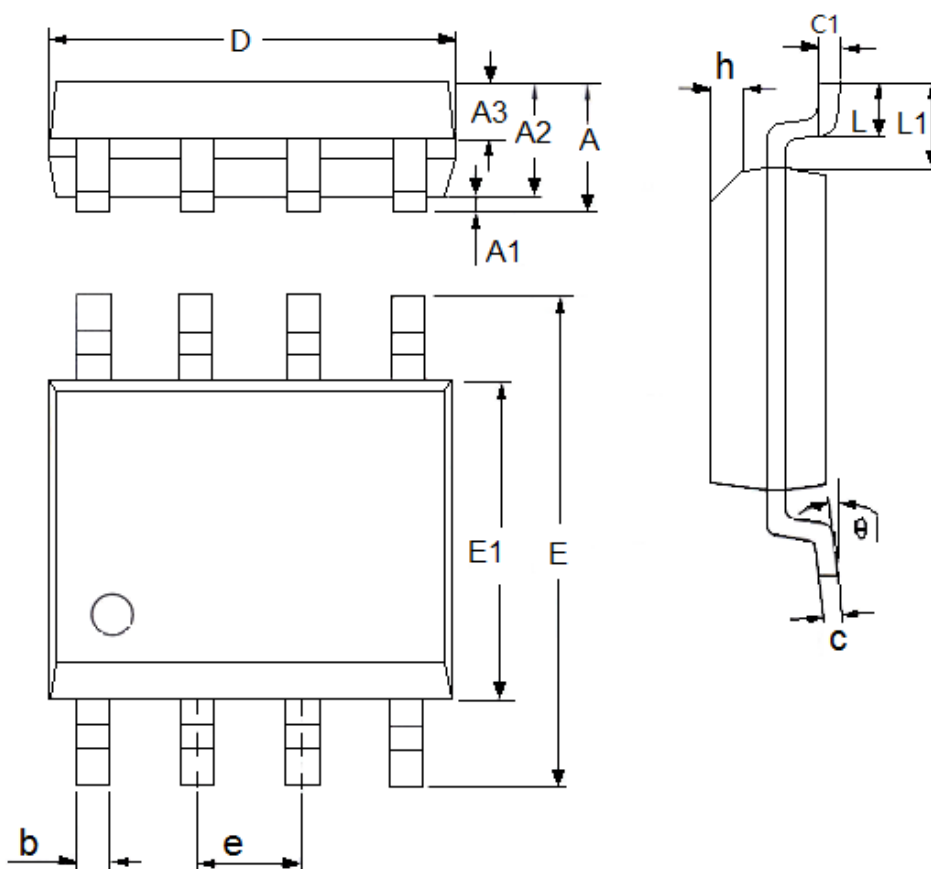

DIM	Millimeters		Inches	
	Min	Max	Min	Max
A	1.3	1.8	0.0512	0.0709
A1	0.05	0.25	0.002	0.0098
A2	1.25	1.65	0.0492	0.065
A3	0.5	0.7	0.0197	0.0276
b	0.3	0.51	0.0118	0.0201
c	0.17	0.25	0.0067	0.0098
D	4.7	5.1	0.185	0.2008
E	5.8	6.2	0.2283	0.2441
E1	3.8	4	0.1496	0.1575
e	1.27(TYP)		0.05(TYP)	
h	0.25	0.5	0.0098	0.0197
L	0.4	1.27	0.0157	0.05
L1	1.04(TYP)		0.0409(TYP)	
θ	0	8°	0	8°
c1	0.25(TYP)		0.0098(TYP)	

- The information described herein is subject to change without notice.
- Nanjing Micro One Electronics Inc is not responsible for any problems caused by circuits or diagrams described herein whose related industrial properties, patents, or other rights belong to third parties. The application circuit examples explain typical applications of the products, and do not guarantee the success of any specific mass-production design.
- Use of the information described herein for other purposes and/or reproduction or copying without the express permission of Nanjing Micro One Electronics Inc is strictly prohibited.
- The products described herein cannot be used as part of any device or equipment affecting the human body, such as exercise equipment, medical equipment, security systems, gas equipment, or any apparatus installed in airplanes and other vehicles, without prior written permission of Nanjing Micro One Electronics Inc.
- Although Nanjing Micro One Electronics Inc exerts the greatest possible effort to ensure high quality and reliability, the failure or malfunction of semiconductor products may occur. The user of these products should therefore give thorough consideration to safety design, including redundancy, fire-prevention measures, and malfunction prevention, to prevent any accidents, fires, or community damage that may ensue.