



High Precision CC/CV Primary-Side Controller ME8310

General Description

The ME8310 is a high performance offline PSR controller for low power AC/DC charger and adapter applications. It operates in primary-side sensing and regulation. Consequently, opto-coupler and ME431 could be eliminated. Proprietary Constant Voltage (CV) and Constant Current (CC) control is integrated as shown in the figure.1 below.

In CC control, the current and output power setting can be adjusted externally by the sense resistor RS at CS pin. In CV control, PFM operations are utilized to achieve high performance and high efficiency. In addition, good load regulation is achieved by the built-in cable drop compensation. The chip consumes very low operation current (typical 420 μ A), it can achieve less than 30mW standby power to meet strict standby power standard.

ME8310 offers comprehensive protection coverage with auto-recovery features including Cycle-by-Cycle current limiting, VDD over voltage protection, feedback loop open protection, short circuit protection, built-in leading edge blanking, VDD under voltage lockout (UVLO), etc.

Typical Application

Low power AC/DC offline SMPS for:

- Cell phone charge
- Digital cameras charger
- Small power adapter
- Auxiliary power for PC, TV, etc.

Features

- $\pm 5\%$ Constant Voltage Regulation at universal AC input
- High precision constant current regulation at universal AC input
- Primary-side sensing and regulation without ME431 and opto-coupler
- Built-in primary winding inductance compensation
- Programmable cable drop compensation
- Driver NMOS switch
- Ultra low start-up current (Typ. 1 μ A)
- VDD over voltage protection
- Built-in feedback loop open protection
- Built-in leading edge blanking (LEB)
- Built-in short circuit protection
- Cycle-by-Cycle current limiting
- VDD under voltage lockout with hysteresis (UVLO)

Package

- 6-pin SOT23-6

Typical Application Circuit

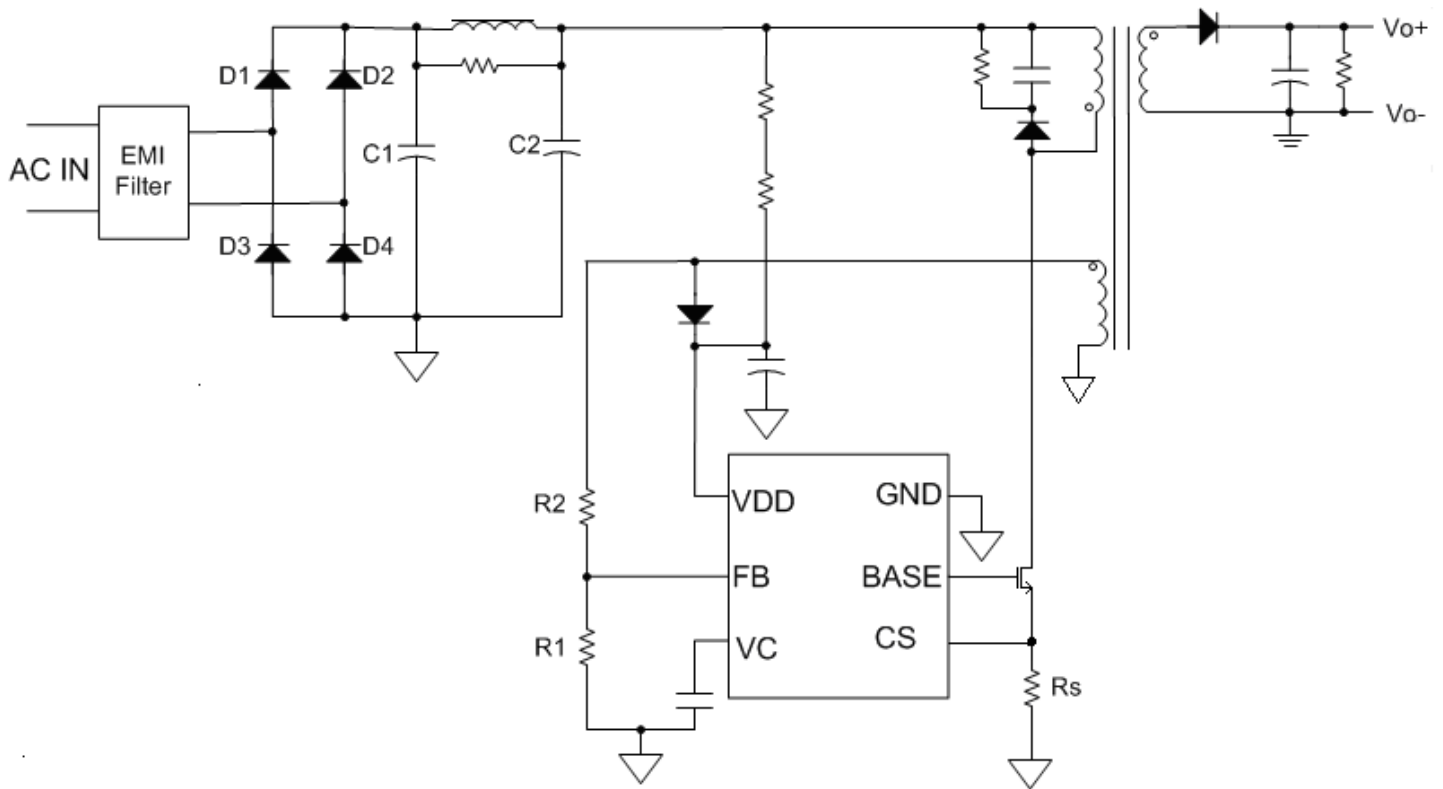

Selection Guide

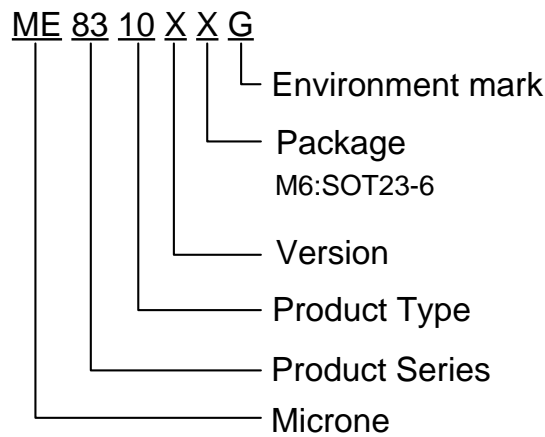

product series	product description
ME8310AM6G	Package: SOT23-6

Pin Configuration & Pin Assignment

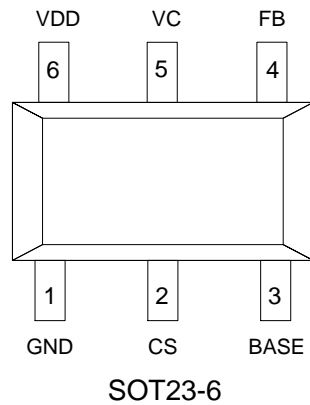

Pin Assignment

Pin Num.	Symbol	Function
1	GND	Ground
2	CS	Current sense input
3	BASE	Drive for MOSFET
4	FB	The voltage feedback from the auxiliary winding. Connected to resistor divider from auxiliary winding reflecting output voltage
5	VC	Low pass filter capacitor for cable compensation
6	VDD	Power supply

Block Diagram

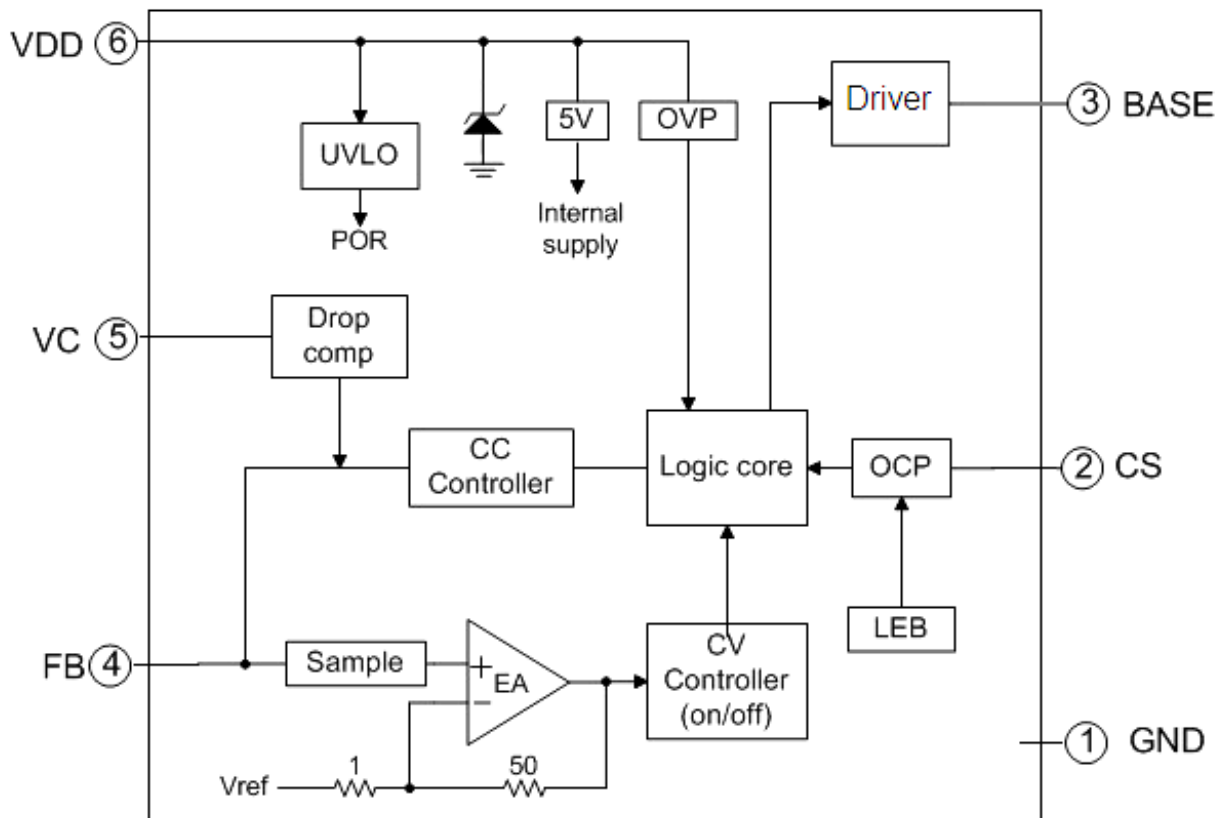

Absolute Maximum Ratings

Parameter	Rating	Unit
Voltage at VDD pin to GND:VDD	-0.3~30	V
Voltage at CS,VC,BASE,FB PIN to GND	-0.3~7	V
Min/Max operating Junction Temperature T _J	-40~150	°C
Lead Temperature (Soldering, 10secs)	260	°C
Min/Max Soldering temperature T _{stg}	-55~150	°C

Caution: The absolute maximum ratings are rated values exceeding which the product could suffer physical damage.

These values must therefore not be exceeded under any conditions.

Electrical Characteristics (T_A =25 °C, V_{DD} =15V, unless otherwise noted.)

Item	Symbol	Test condition	Min	Typ.	Max	Unit
Supply Voltage(VDD) section						
Start-up current	I _{start-up}	VDD=11V	-	1	3	μA
Static current	I _{static}	VDD=15V	-	420	500	μA
VDD under voltage lockout exit	UVLO(off)		12.5	13.5	14.5	V
VDD under voltage lockout enter	UVLO(on)		7.4	8.0	8.6	V
VDD over voltage protection	V _{DD_OVP}		30	31	32	V
Max. operating voltage	V _{DD_max}		-	-	30	V
Current sense input section						
LEB time	T _{LEB}		-	0.5	-	μS
Over current threshold	V _{th_ocp}		485	500	515	mV
OCP propagation delay	Td_oc	From OCP comparator to	-	100	-	nS
FB input section						
Reference voltage for feedback	V _{REF_FB}	VDD=15V, V _{CS} =4V	1.94	2.00	2.10	V
Minimum pause	T _{pause_min}		-	2.0	-	μS
Maximum pause	T _{pause_max}		8	10	12	mS
Maximum cable compensation current	I _{comp_cable}	VDD=15V, V _{CS} =4V	42	45	49	μA
Base drive section						
Base sourcing Clamping voltage	V _{base_camp}		14	14.7	15.5	V

Operation Description

ME8310 is a cost effective PSR controller optimized for off-line low power AC/DC applications including battery chargers. It operates in primary side sensing and regulation, thus opto-coupler and ME431 are not required. Proprietary built-in CV and CC control can achieve high precision CC/CV control meeting most charger application requirements.

●Startup Current and Start up Control

Startup current of ME8310 is designed to be very low so that VDD could be charged up above UVLO threshold and starts up quickly. A large value startup resistor can therefore be used to minimize the power loss in application.

●Operating Current

The Operating current of ME8310 is as low as 420µA. Good efficiency and very low standby power(less than 30mW) is achieved with the low operating current.

●CC/CV Operation

ME8310 is designed to produce good CC/CV control characteristic as shown in the Fig.1. In charger applications, a discharged battery charging starts in the CC portion of the curve until it is nearly full charged and smoothly switches to operate in CV portion of the curve. The CC portion provides output current limiting. In CV operation, the output voltage is regulated through the primary side control. In CC operation mode, ME8310 will regulate the output current constant regardless of the output voltage drop.

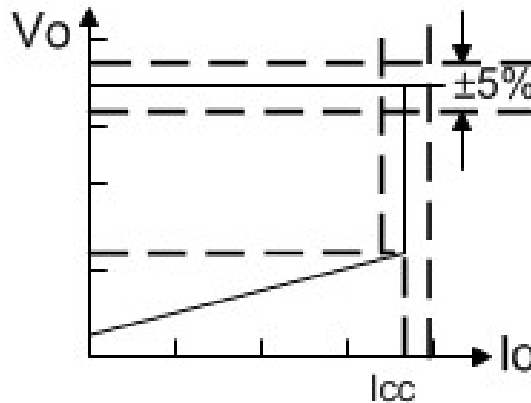

Fig.1 : Typical CC/CV curve

●Principle of Operation

To support ME8310 proprietary CC/CV control, power dissipation in a switching mode power supply is from switching loss on the MOSFET transistor, the core system needs to be designed in DCM mode for flyback system (Refer to Typical Application Diagram).

In the DCM flyback converter, the output voltage can be sensed via the auxiliary winding. During MOSFET turn-on time, the load current is supplied from the output filter capacitor, Co. The current in the primary winding ramps up. When MOSFET turns off, the energy stored in the primary winding is transferred to the secondary side

such that the current in the secondary winding is : $I_s = \frac{N_p}{N_s} * I_p$.

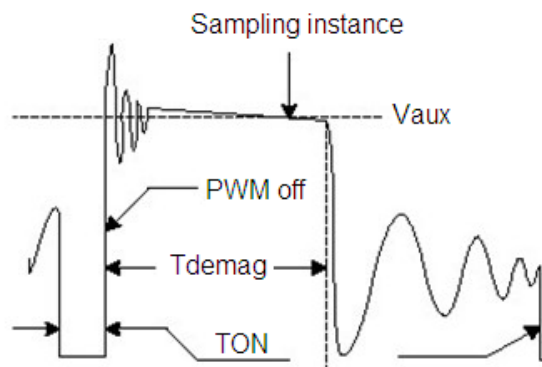

Fig.2: Auxiliary voltage waveform

The auxiliary voltage reflects the output voltage as shown in Fig.2 and it is given by

$$V_{AUX} = \frac{N_{AUX}}{N_s} * (V_o + \Delta V)$$

Where the ΔV indicates the drop voltage of the output Diode.

Via a resistor divider connected between the auxiliary winding and FB (pin 4), the auxiliary voltage is sampled at the middle of the demagnetization and it is hold until the next sampling. The sampled voltage is compared with V_{REF} (2.0V) and the error is amplified. The error amplifier output reflects the load condition and controls the switching off time to regulate the output voltage, thus constant output voltage can be achieved. When the sampled voltage is below V_{REF} and the error amplifier output reaches its minimum, the switching frequency is controlled by the sampled voltage to regulate the output current, thus the constant output current can be achieved.

•Adjustable CC point and Output Power

In ME8310, the CC point and maximum output power can be externally adjusted by external current sense resistor R_s at CS pin as illustrated in typical application diagram. The larger R_s , the smaller CC point is, and the smaller output power becomes, and vice versa as shown in Fig.3.

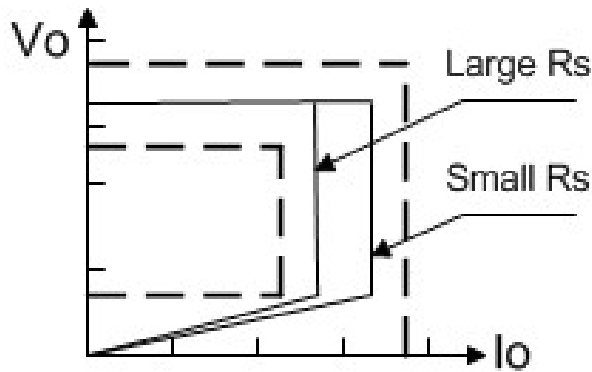

Fig.3: Adjustable output power by changing

•Operation switching frequency

The switching frequency of ME8310 is adaptively controlled according to the load conditions and the operation modes. For flyback operating in DCM, The maximum output power is given by

$$P_{O_{MAX}} = \frac{1}{2} * L_p * F_{sw} * I_p^2$$

Where L_p indicates the inductance of primary winding and I_p is the peak current of primary winding. Refer to the equation below, the change of the primary winding inductance results in the change of the maximum output power and the constant output current in CC mode. To compensate the change from variations of primary winding inductance, the switching frequency is locked by an internal loop such that the switching frequency is

$$F_{sw} = \frac{1}{2 * T_{demag}}$$

Since T_{demag} is inversely proportional to the inductance, as a result, the product L_p and F_{sw} is constant, thus the maximum output power and constant current in CC mode will not change as primary winding inductance changes. Up to $\pm 10\%$ variation of the primary winding inductance can be compensated.

•Programmable Cable drop Compensation

In ME8310, cable drop compensation is implemented to achieve good load regulation. An offset voltage is

generated at FB pin by an internal current flowing into the resistor divider. The current is proportional to the switching off time, as a result, it is inversely proportional to the output load current, and the drop due to the cable loss can be compensated. As the load current decreases from full-load to no-load, the offset voltage at FB will increase. It can also be programmed by adjusting the resistance of the divider to compensate the drop for various cable lines used. The percentage of maximum compensation is

$$\frac{\Delta V}{V_{out}} = \frac{I_{comp_cable} * (R1 // R2) * 10^{-6}}{2} * 100\%$$

ΔV is load compensation voltage and V_{out} is output voltage; For example: $R1 // R2 = 3K\Omega$, the percentage of maximum compensation is

$$\frac{\Delta V}{V_{out}} = \frac{45 * 3000 * 10^{-6}}{2} * 100\% = 6.75\%$$

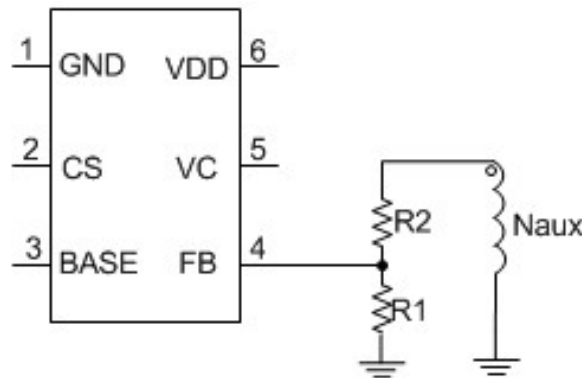

●Current Sensing and Leading Edge Blanking

Cycle-by-Cycle current limiting is offered in ME8310. The switch current is detected by a sense resistor into the CS pin. An internal leading edge blanking circuit chops off the sensed voltage spike at initial power MOSFET on state so that the spike at initial power MOSFET on state so that the external RC filtering on sense input is no longer needed.

●Protection Control

Good power supply system reliability is achieved with its rich protection features including Cycle-by-Cycle current limiting (OCP), VDD over voltage protection, feedback loop open protection, short circuit protection and Under Voltage Lockout on VDD (UVLO). VDD is supplied by transformer auxiliary winding output. The output of ME8310 is shut down when VDD drops below UVLO (ON) and the power converter enters power on start-up sequence thereafter.

Typical performance characteristics

(1) IC Supply Current vs. Input Voltage

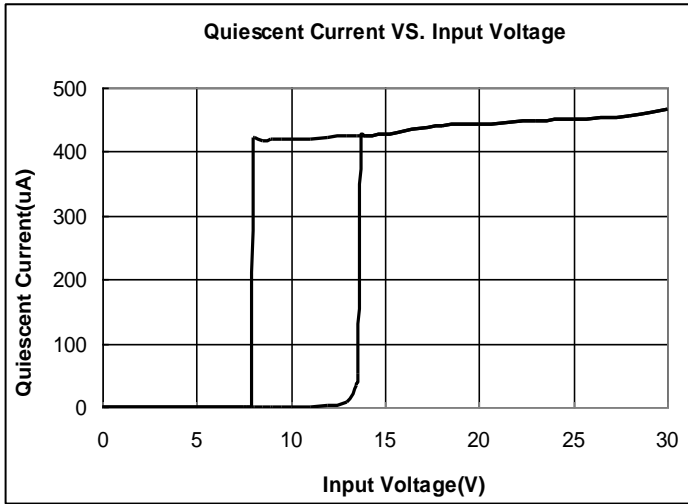

(2) Supply Current after startup vs. Temperature

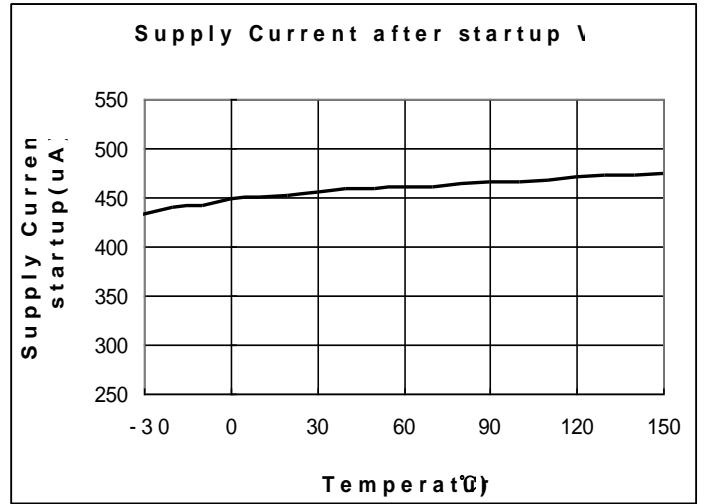

(3) Startup Voltage VS. Temperature

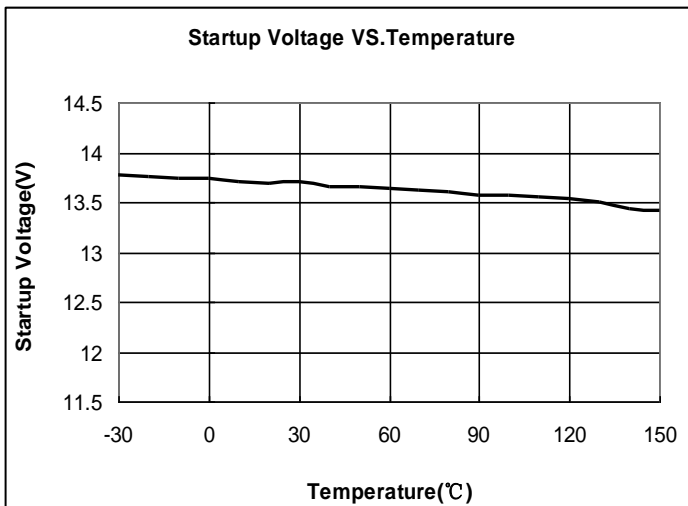

(4) VDD UVLO enter voltage vs. Temperature

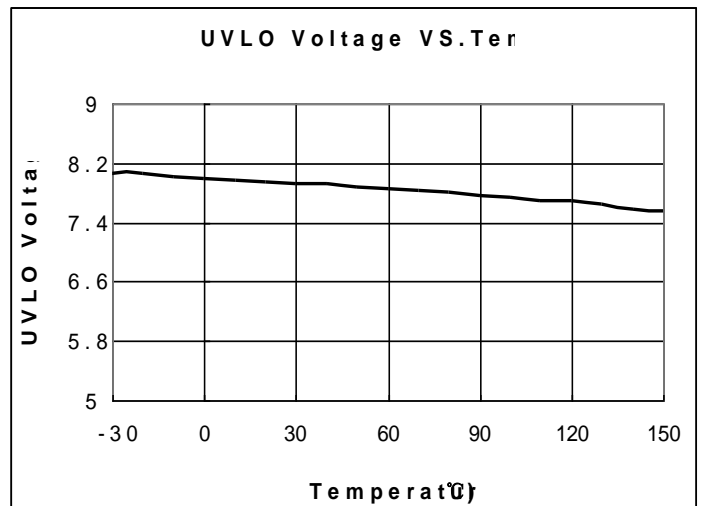

(5) Feedback voltage vs. Temperature

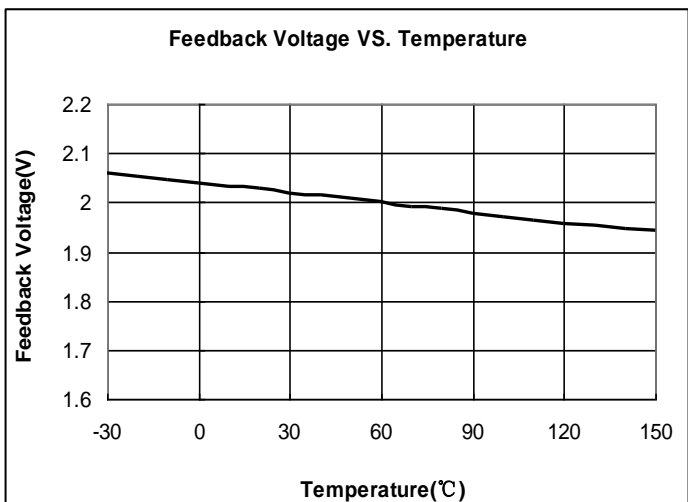

(6) Feedback Voltage VS. Input Voltage

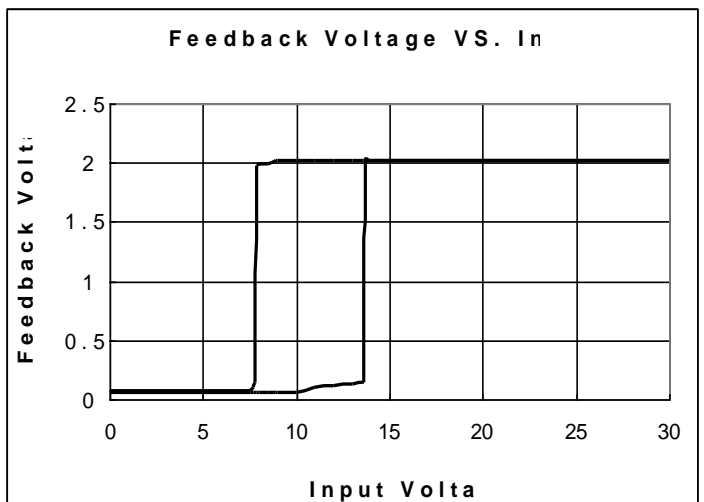

Packaging Information

● SOT23-6

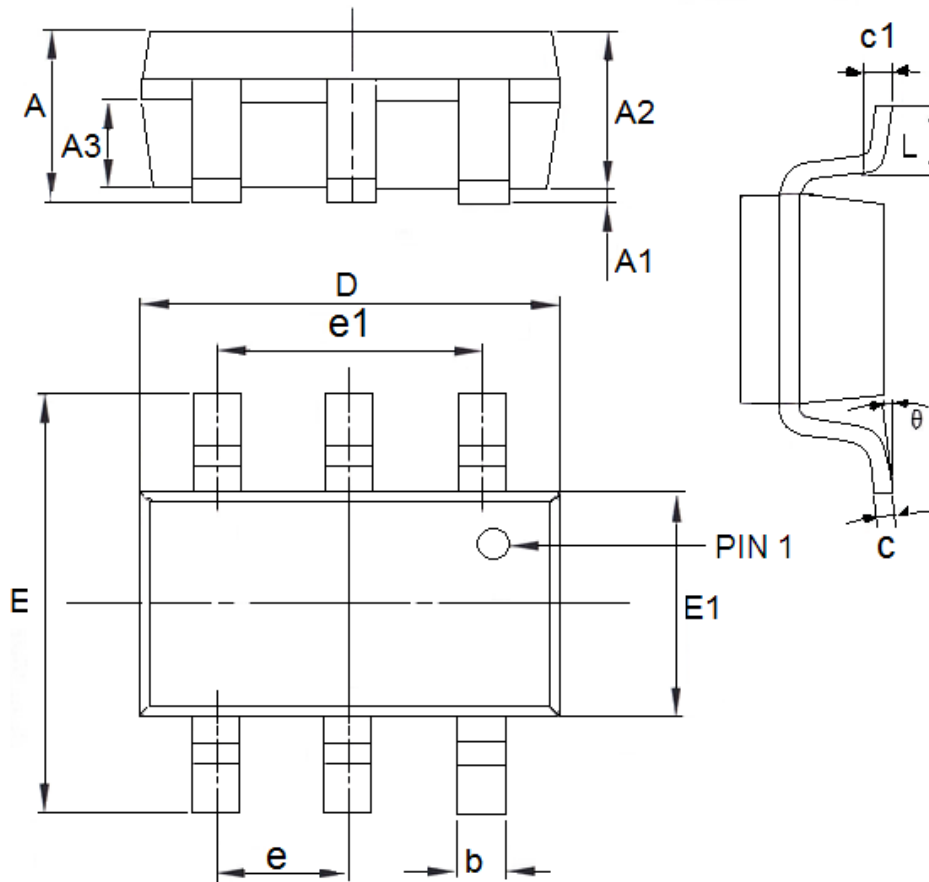

DIM	Millimeters		Inches	
	Min	Max	Min	Max
A	1	1.5	0.0394	0.0591
A1	0	0.15	0.0000	0.0059
A2	0.9	1.3	0.0354	0.0512
A3	0.55	0.75	0.0217	0.0295
b	0.25	0.5	0.0098	0.0197
c	0.1	0.25	0.0039	0.0098
D	2.7	3.12	0.1063	0.1228
e1	1.9(TYP)		0.0748(TYP)	
E	2.6	3.1	0.1024	0.1220
E1	1.4	1.8	0.0551	0.0709
e	0.95(TYP)		0.0374(TYP)	
L	0.25	0.6	0.0098	0.0236
θ	0	8°	0.0000	8°
c1	0.2(TYP)		0.0079(TYP)	

- The information described herein is subject to change without notice.
- Nanjing Micro One Electronics Inc is not responsible for any problems caused by circuits or diagrams described herein whose related industrial properties, patents, or other rights belong to third parties. The application circuit examples explain typical applications of the products, and do not guarantee the success of any specific mass-production design.
- Use of the information described herein for other purposes and/or reproduction or copying without the express permission of Nanjing Micro One Electronics Inc is strictly prohibited.
- The products described herein cannot be used as part of any device or equipment affecting the human body, such as exercise equipment, medical equipment, security systems, gas equipment, or any apparatus installed in airplanes and other vehicles, without prior written permission of Nanjing Micro One Electronics Inc.
- Although Nanjing Micro One Electronics Inc exerts the greatest possible effort to ensure high quality and reliability, the failure or malfunction of semiconductor products may occur. The user of these products should therefore give thorough consideration to safety design, including redundancy, fire-prevention measures, and malfunction prevention, to prevent any accidents, fires, or community damage that may ensue.