



## Linear Adjustable Constant Current LED Driver MEL7136

### General Description

The MEL7136A is a constant current regulator for driving LEDs with low quiescent current and low dropout voltage. The current is adjustable from 10mA to 1A with an external resistor.

The MEL7136B is only a controller, and must be connected to an external NMOS. MEL7136B is an external transistor, is suitable for applications requiring a high output current. The output current of ME7136B can be adjusted by external DC control voltage or PWM control.

Only one external resistor is required to achieve a constant current LED driver. Soft start, thermal protection and low voltage protection are also provided.

The driver pin EXT is provided for current and voltage extension. Adding an external NMOS or NPN transistor to this pin can extend current and voltage range.

### Typical Application

- Power Led driver and controller

### Features

- MEL7136B is only a controller, and must be connected to an external NMOS.
- The output current of ME7136B is adjustable
- Sink current: 10mA to 1A adjustable with an external resistor
- Current and voltage range extendable by adding an external NMOS or NPN transistor
- Power supply voltage:  
MEL7136A/B: 2.7~18V  
MEL7136C: 2~18V
- Low drop out voltage: 50mV@1A
- Low quiescent current: 80uA
- Thermal Shutdown protection: 165°C
- Soft start
- Low voltage protection:  
MEL7136A/B: 2.4V  
MEL7136C: 1.7V

### Package

- MEL7136A: 5-pin SOT89-5  
8-pin ESOP8
- MEL7136B: 5-pin SOT23-5
- MEL7136C: 5-pin SOT89-5

## Selection Guide

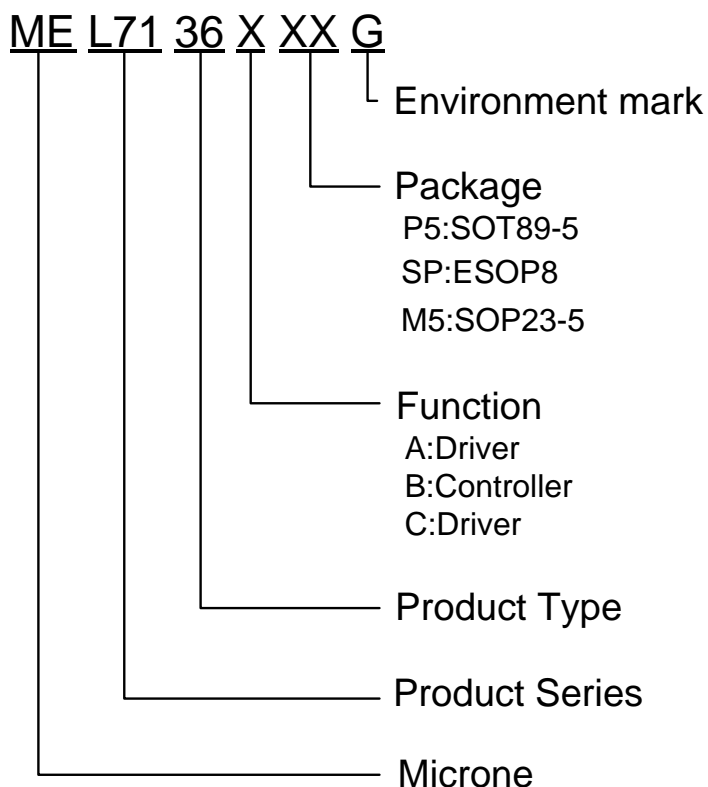

product series	product description
MEL7136AP5G	Package:SOT89-5
MEL7136ASPG	Package:ESOP8
MEL7136BM5G	Package:SOP23-5
MEL7136CP5G	Package:SOT89-5

**NOTE:** If you need other voltage and package, please contact our sales staff.

## Pin Configuration & Pin Assignment

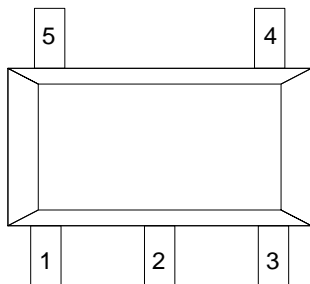

SOT23-5(only for MEL7136B)

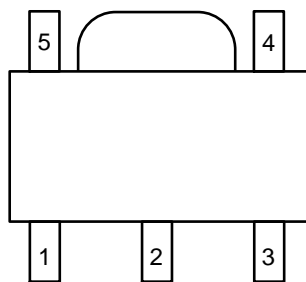

SOT89-5

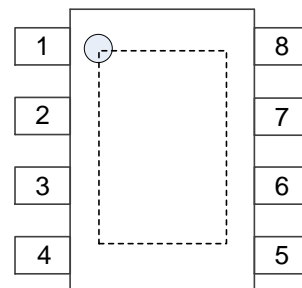

ESOP8

## Pin Assignment

### MEL7136A

Pin Number		Pin Name	Functions
ESOP8	SOT89-5		
2	1	CS	Output current detection
1	2	D(LED)	The negative input feet of LED
3	3	VDD	Power Input
5	4	GND	Ground
7	5	EXT	Driving external NMOS
4,6,8		NC	No connection

### MEL7136B

Pin Number		Pin Name	Functions
SOT23-5			
1		NC	NC
2		GND	Ground
3		VDD	Power Input
4		CS	Output current detection
5		EXT	Driving external NMOS

### MEL7136C

Pin Number		Pin Name	Functions
SOT89-5			
1		CS	Output current detection
2		D(LED)	The negative input feet of LED
3		VDD	Power Input
4		GND	Ground
5		EXT	Driving external NMOS

## Block Diagram

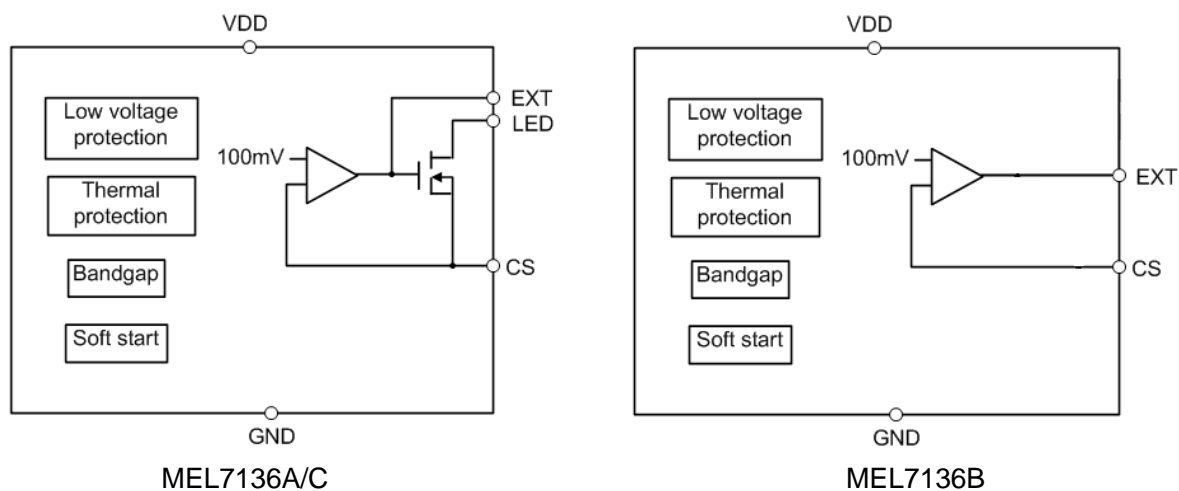

## Absolute Maximum Ratings

Parameter	Symbol	Ratings	Units	
Input Voltage	$V_{DD}$	18	V	
Voltage on LED,CS	$V_{LED}, V_{CS}$	$-0.3 \sim V_{DD}+0.3$	V	
Voltage on EXT	$V_{EXT}$	6	V	
Output Current	$I_{OUT}$	1.5	A	
Power Dissipation	SOT89-5	$P_D$	500	mW
			1300 (PCB mounted) <sup>(*)</sup>	
	ESOP8	$P_D$	2000	mW ( $T=25^{\circ}C$ )
2000 (PCB mounted) <sup>(*)</sup>				
Thermal resistance (Junction to air)	SOT89-5	$\theta_{JA}$	100	$^{\circ}C/W$
	ESOP8	$\theta_{JA}$	63	$^{\circ}C/W$
	SOT23-5	$\theta_{JA}$	210	$^{\circ}C/W$
Operating Temperature Range	$T_{OPR}$	$-40 \sim +85$	$^{\circ}C$	
Storage Temperature Range	$T_{STG}$	$-55 \sim +150$	$^{\circ}C$	
Maximum junction temperature	$T_J$	$-40 \sim +150$	$^{\circ}C$	
Lead Temperature		$260^{\circ}C, 4sec$		
ESD(ESD voltage for human body model )	$V_{ESD}$	2000	V	

\*1:The power dissipation figure shown in PCB mounted. Please refer to page8-9 for details.

## Electrical Characteristics

MEL7136A/MEL7136B/MEL7136C ( $V_{DD}=3.6V$ ,  $T_a=25^{\circ}C$ , unless otherwise noted)

Parameter		Symbol	Conditions	Min.	Typ.	Max.	Units
Sink Current		$I_{sink}$	$V_{DD}=3.6V$	10	-	1000	mA
Input Voltage	MEL7136A/B	$V_{DD}$	$I_{sink}=1A$	2.7	-	18	V
	MEL7136C			2	-	18	
CS Voltage		$V_{CS}$		95	100	105	mV
Sink current accuracy		$\Delta I_{LED}/I_{LED}$	$I_{sink}=1A$	-5	-2.5	5	%
Load Regulation		LDR	$V_{LED}=0.2V$ to $3V$ , $V_{DD}=3.6V$	-	0.1	2	mA/V
Line Regulation		LNR	$V_{LED}=3V$ , $3.6V \leq V_{DD} \leq 18V$	-	0.4	2	mA/V
Output dropout voltage		$V_{drop}$	$V_{DD}=3.6V$ , $V_{LED}=0.5V$	-	50	100	mV
Quiescent Current		$I_{SS}$	$V_{DD}=3.6V$	-	80	100	uA
Low Voltage Protection	MEL7136A/B	$V_{up}$	Start voltage, $V_{IN}$ rises	-	2.7	2.9	V
		$V_{down}$	Shutdown voltage, $V_{IN}$ falls	2.4	2.55	-	
	MEL7136C	$V_{up}$	Start voltage, $V_{IN}$ rises	-	2.0	2.1	
		$V_{down}$	Shutdown voltage, $V_{IN}$ falls	1.7	1.8	-	
Low voltage hysteresis		$V_{hys}$		-	0.15	-	V
Maximal EXT Voltage		$V_{EXT}$	$V_{DD}=5.0V$ , $V_{CS}=0V$	2.5	3.6	4.5	V
Thermal Shutdown protection		$T_{sd}$		-	165	-	$^{\circ}C$

## Type Characteristics

(1) Quiescent Current VS. Input Voltage (No external component)

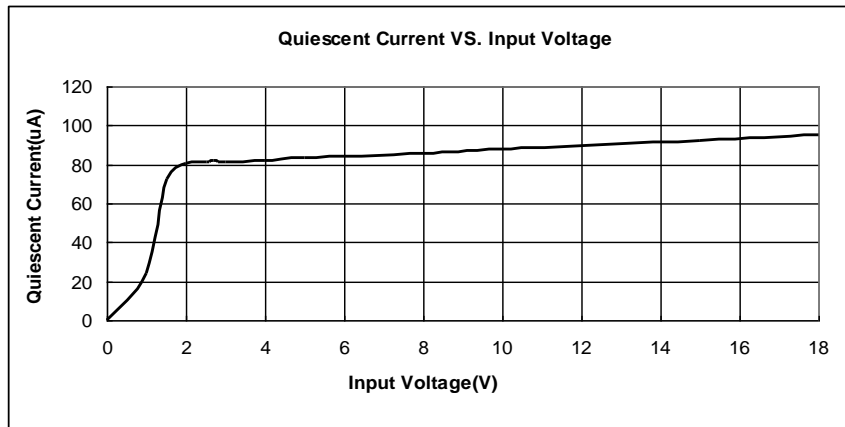

(2) Quiescent Current VS. Temperature ( $V_{DD}=3.6V$ )

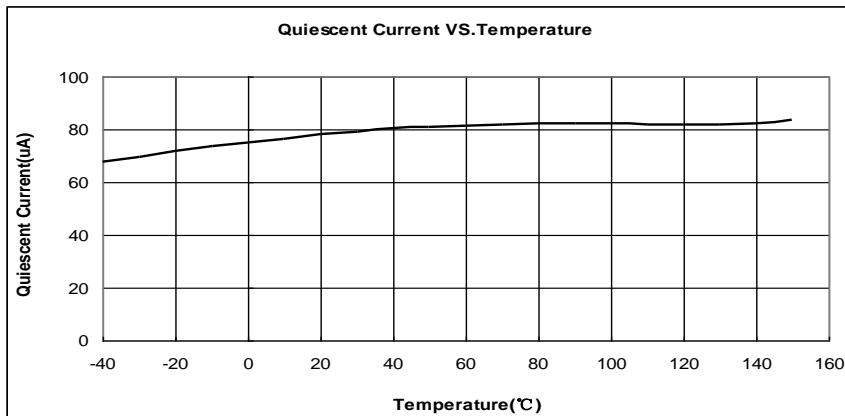

(3) Dropout Voltage VS. Output Current ( $V_{DD}=3.6V$ )

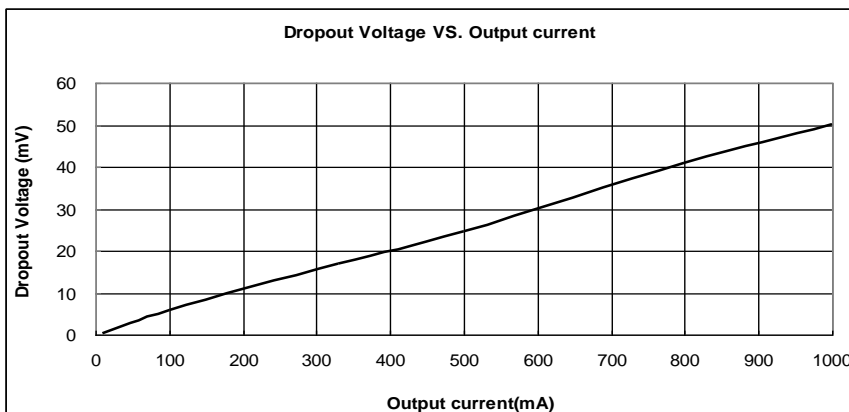

## Adjustment of the MEL7136B output current

### 1. Output current adjustment by external DC control voltage

The Dimming pin can be driven by an external dc voltage ( $V_{DC}$ ), as shown, to adjust the output current to a value below the nominal average value defined by  $R_{EXT}$ .  $V_{REF}=0.1V$ .

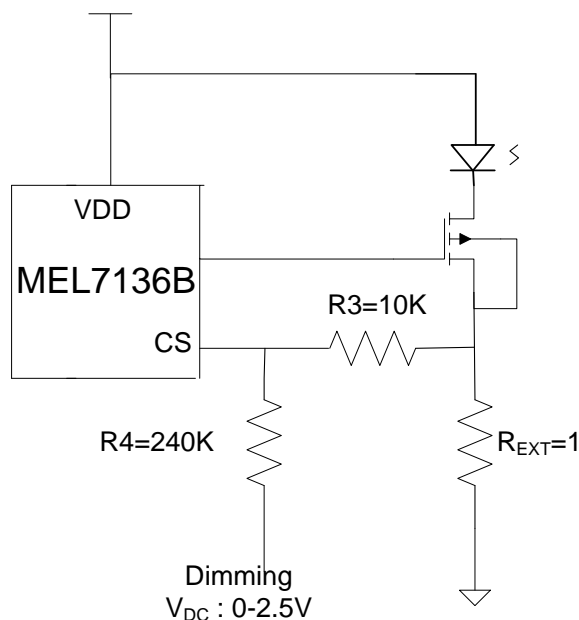

Figure 1. Dimming Control Using a DC Voltage

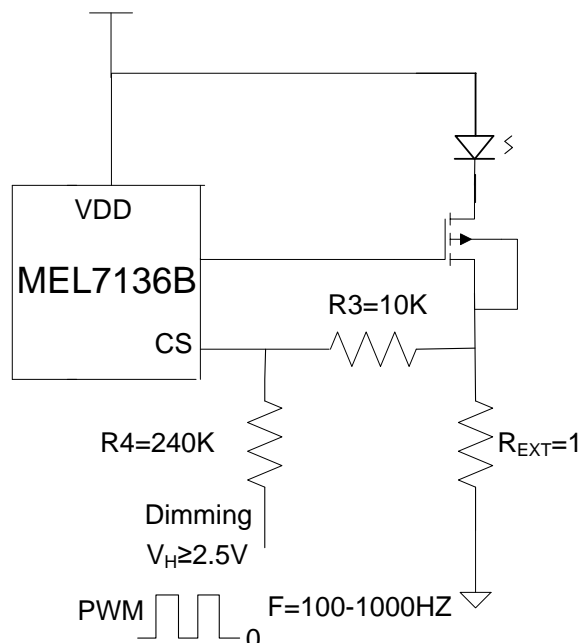

Figure 2. Dimming Control Using a PWM Signal

$R4:R3=24:1$ , The average output current is given by:

$$I_{LED} = \frac{V_{REF} - \frac{R3 \times (V_{DC} - V_{REF})}{R4}}{R_{EXT}} \quad (0 \leq V_{DC} \leq 2.5V)$$

$$I_{LED} = 0 \quad (2.5 \leq V_{DC} \leq V_{DD})$$

### 2. Output current adjustment by PWM control

A Pulse Width Modulated (PWM) signal with duty cycle PWM can be applied to the Dimming pin, as shown below, to adjust the output current to a value below the nominal average value set by resistor  $R_{EXT}$ .  $V_{REF}=0.1V$ .

$R4:R3=24:1$ , The average output current is given by:

$$I_{LED} = \frac{V_{REF} - \frac{R3 \times (2.5 \times \text{Duty} - V_{REF})}{R4}}{R_{EXT}} \quad (2.5 \leq V_{PWM} \leq V_{DD} \ \& \ 0 \leq \text{Duty} \leq 100\%)$$

PWM dimming provides reduced brightness by modulating the LED's forward current between 0% and 100%. The LED brightness is controlled by adjusting the relative ratios of the on time to the off time. A 25% brightness level is achieved by turning the LED on at full current for 25% of one cycle. To ensure this switching process between on and off state is invisible by human eyes, the switching frequency must be greater than 100 Hz. Above 100 Hz, the

human eyes average the on and off times, seeing only an effective brightness that is proportional to the LED's on-time duty cycle. The advantage of PWM dimming is that the forward current is always constant, therefore the LED color does not vary with brightness as it does with analog dimming. Pulsing the current provides precise brightness control while preserving the color purity. The best dimming frequency of MEL7136B is 100Hz to 1kHz.

## Power dissipation

- SOT89-5 power dissipation

The power dissipation data for the SOT89-5 is shown as below. The value of power dissipation varies with the mount board conditions. Please use this data as the reference data taken in the following condions.

### 1. Measurement condition

- Condition: Mount on a board
- Ambient: Natural convection
- Soldering: Lead(pb) free
- Board: Dimensions 30\*35mm (1050mm<sup>2</sup> in one side)  
Copper(Cu) traces occupy 50% of the board  
Area in top and back faces
- Material: Glass Epoxy (FR-4)
- Thickness: 1.6mm
- Through-hole: 5\*0.8 Diameter

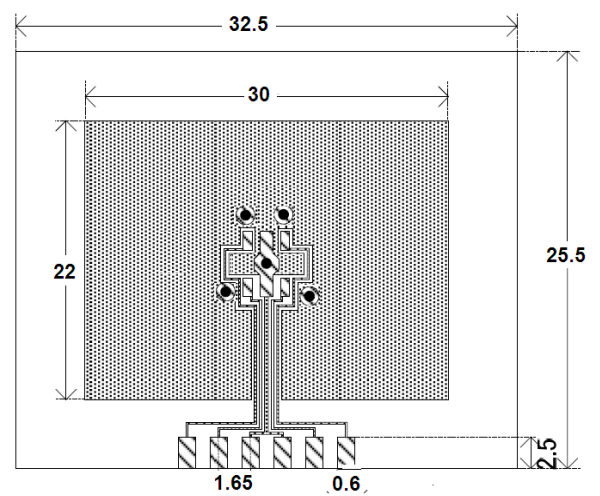

Evaluation Board( Unit:mm)

### 2. Power dissipation vs. Ambient temperature

Board Mount ( $T_j \text{ max}=125 \text{ }^\circ\text{C}$ )

Ambient Temperature( $^\circ\text{C}$ )	Power Dissipation(mW)	Thermal Resistance( $^\circ\text{C}/\text{W}$ )
25	1300	76.92
85	520	

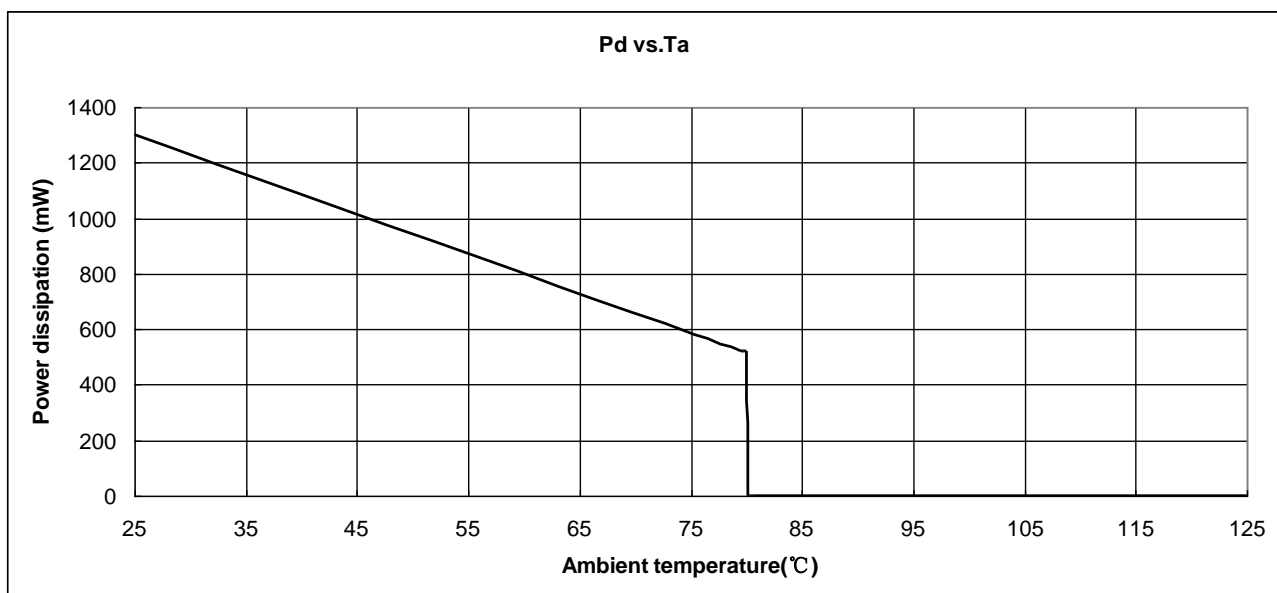

## ● ESOP8 power dissipation

The power dissipation data for the ESOP8 is shown as below. The value of power dissipation varies with the mount board conditions. Please use this data as the reference data taken in the following conditions.

### 1. Measurement condition

- Condition: Mount on a board
- Ambient: Natural convection
- Soldering: Lead(pb) free
- Board: Dimensions 30\*35mm (1050mm<sup>2</sup> in one side)  
Copper(Cu) traces occupy 50% of the board  
Area in top and back faces
- Material: Glass Epoxy (FR-4)
- Thickness: 1.6mm
- Through-hole: 4\*0.8 Diameter

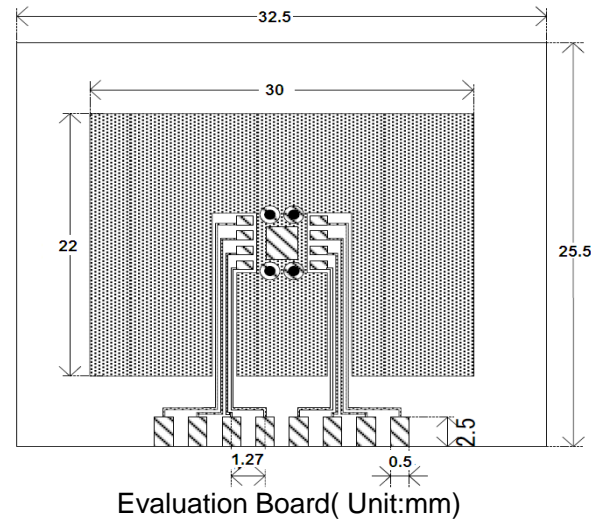

### 2. Power dissipation vs. Ambient temperature

Board Mount ( $T_j \text{ max}=125 \text{ }^\circ\text{C}$ )

Ambient Temperature( $^\circ\text{C}$ )	Power Dissipation(mW)	Thermal Resistance( $^\circ\text{C/W}$ )
25	2000	66.67
85	700	

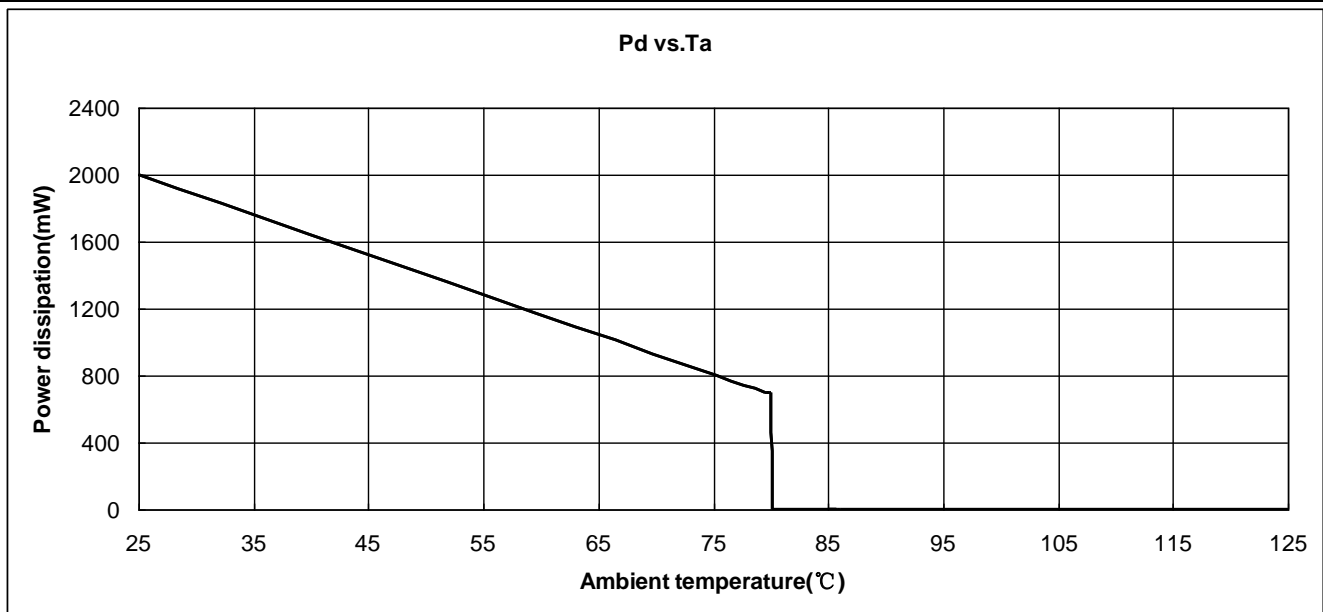

## Typical Application Circuit

### MEL7136A

Low Voltage And Light Load (Under 1A)

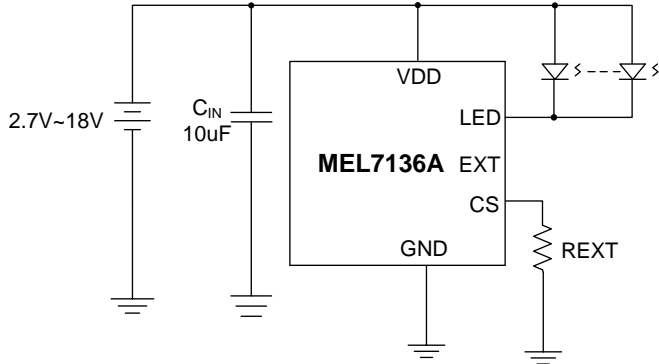

Low Voltage And Heavy Load (Exceed 1A)

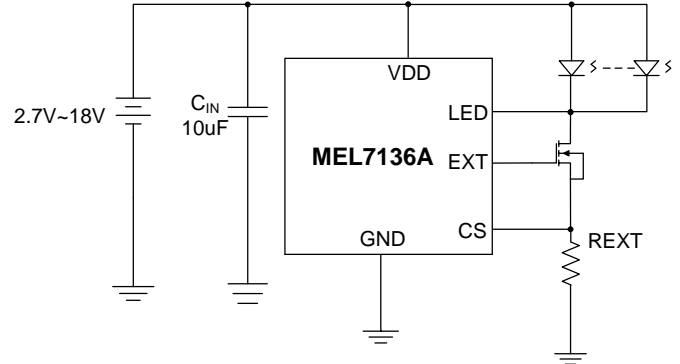

High Voltage Application

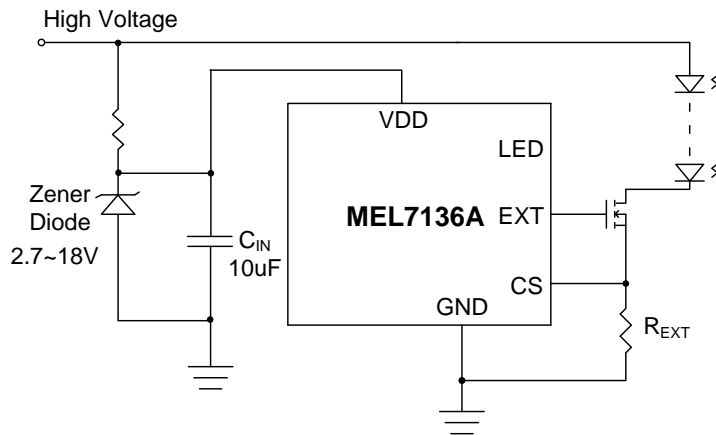

### MEL7136B

Low Voltage Application

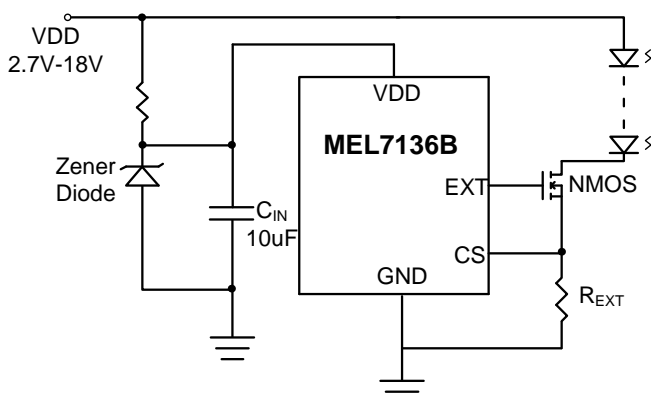

High Voltage Application

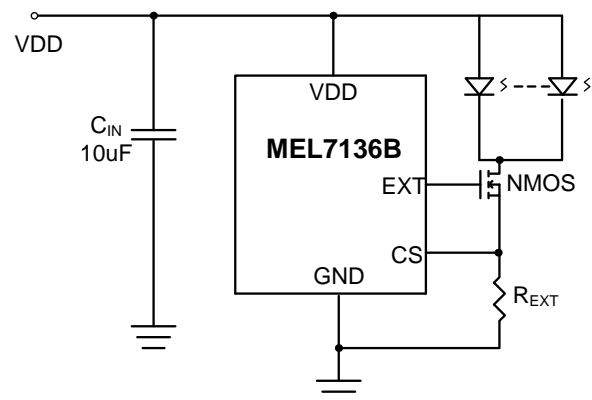

## Adjustable Output Current Application

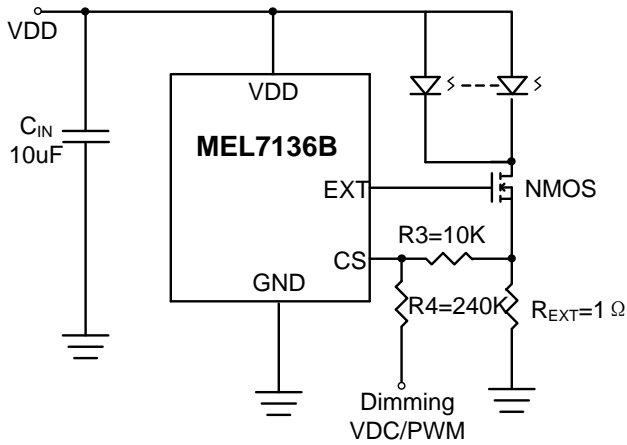

## MEL7136C

Low Voltage And Light Load (Under 1A)

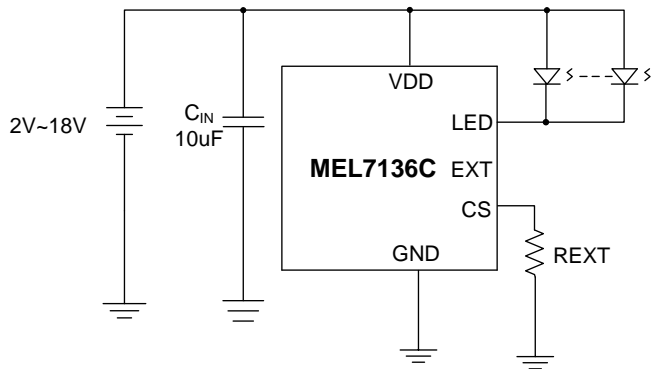

Low Voltage And Heavy Load (Exceed 1A)

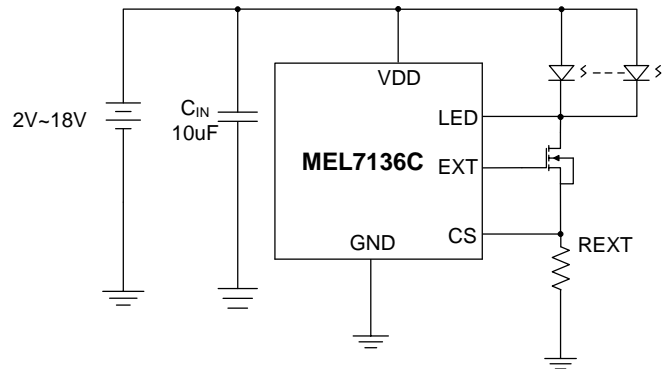

## High Voltage Application

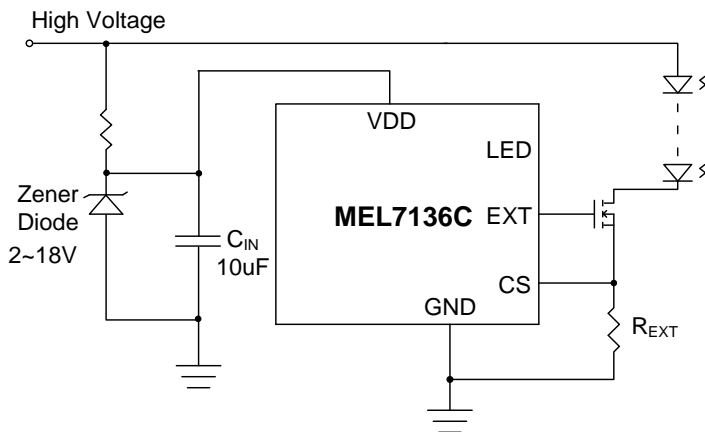

## R<sub>EXT</sub> Resistor Value selection:

R <sub>EXT</sub> (Ω)	I <sub>LED</sub> (mA)
10	10
1	100
0.286	350
0.1	1000

$$I_{LED} = \frac{V_{CS}}{R_{EXT}}$$

## Package Information

- Package Type:SOT89-5

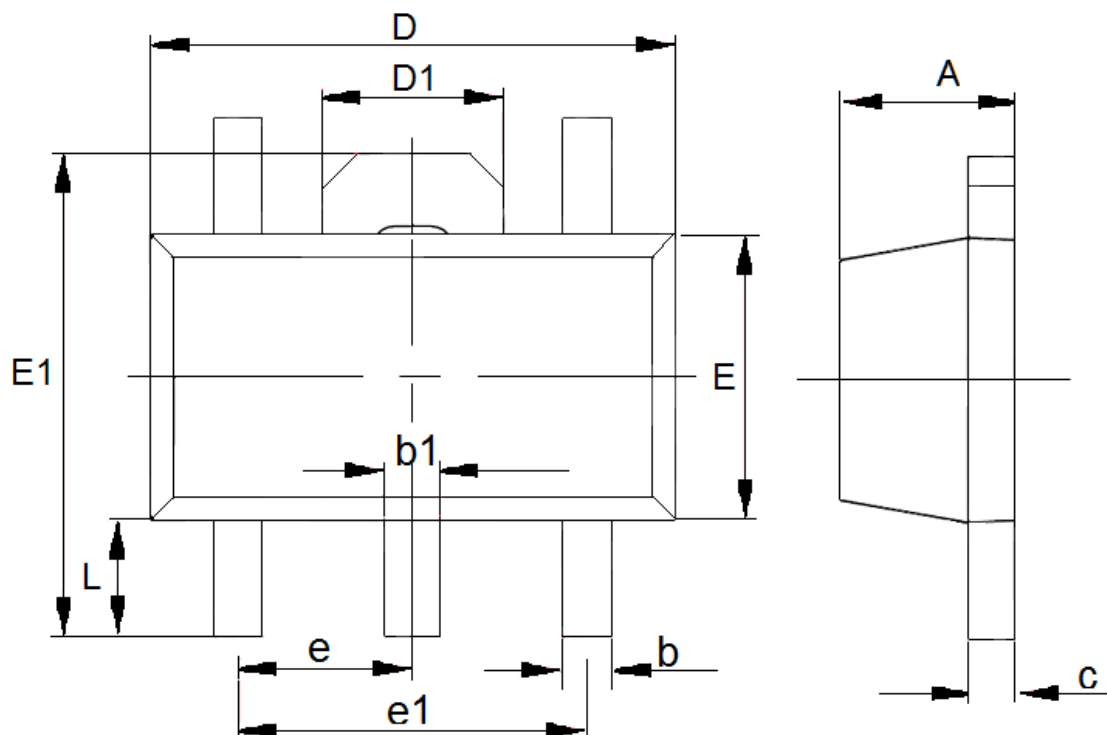

DIM	Millimeters		Inches	
	Min	Max	Min	Max
A	1.4	1.6	0.0551	0.0630
b	0.32	0.52	0.0126	0.0205
b1	0.38	0.58	0.0150	0.0228
c	0.35	0.47	0.0138	0.0185
D	4.4	4.6	0.1732	0.1811
D1	1.55(TYP)		0.061(TYP)	
e1	3(TYP)		0.1181(TYP)	
E	2.3	2.6	0.0906	0.1023
E1	3.94	4.4	0.1551	0.1732
e	1.5(TYP)		0.0591(TYP)	
L	0.8	1.2	0.0315	0.0472

● Package Type:ESOP8

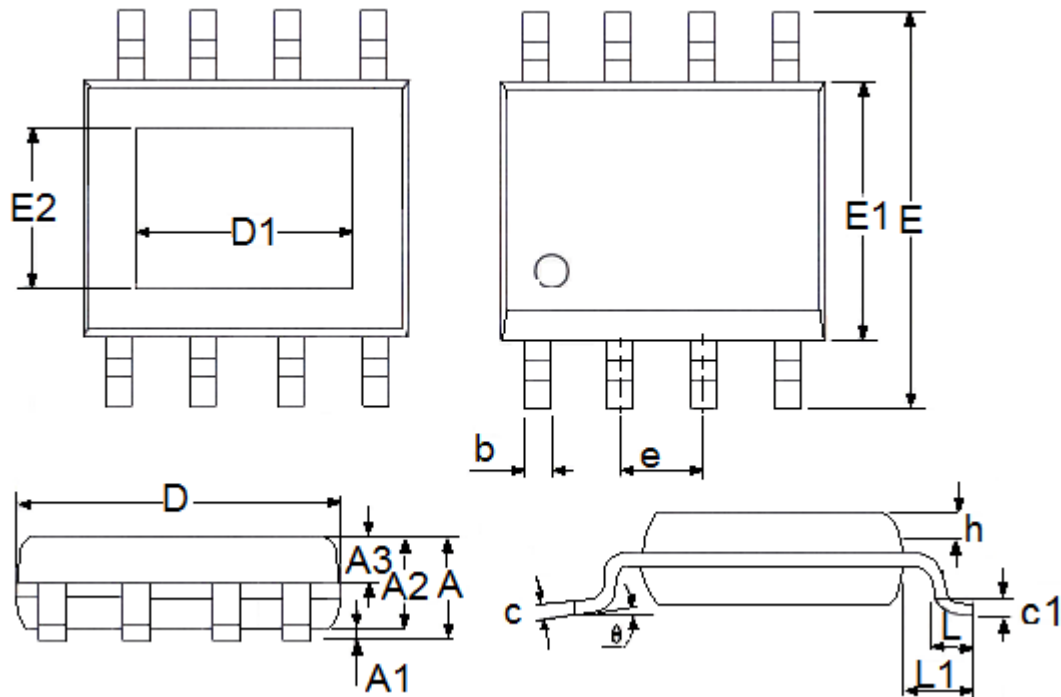

DIM	Millimeters		Inches	
	Min	Max	Min	Max
A	1.3	1.75	0.0512	0.0689
A1	0	0.2	0.0000	0.0079
A2	1.25	1.65	0.0492	0.0650
A3	0.5	0.7	0.0197	0.0276
b	0.33	0.51	0.0130	0.0201
c	0.17	0.25	0.0067	0.0098
D	4.7	5.1	0.1850	0.2008
E	5.8	6.2	0.2283	0.2441
E1	3.8	4	0.1496	0.1575
e	1.27(TYP)		0.05(TYP)	
h	0.25	0.5	0.0098	0.0197
L	0.4	1.27	0.0157	0.0500
L1	1.04(TYP)		0.0409(TYP)	
$\theta$	0	8°	0.0000	8°
c1	0.25(TYP)		0.0098(TYP)	
D1(90*90)	2.09(TYP)		0.0823(TYP)	
D1(95*130)	3.1(TYP)		0.122(TYP)	
E2(90*90)	2.09(TYP)		0.0823(TYP)	
E2(95*130)	2.21(TYP)		0.087(TYP)	

● Package Type: SOT23-5

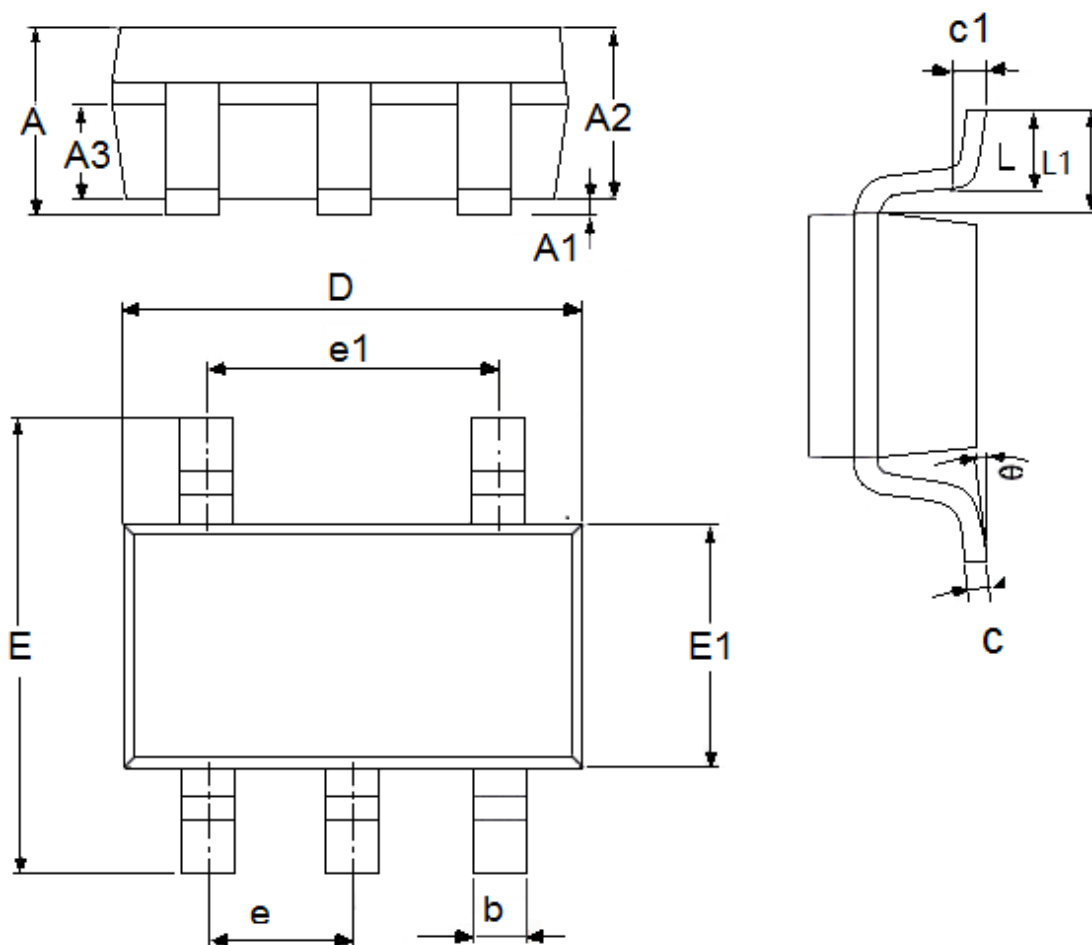

DIM	Millimeters		Inches	
	Min	Max	Min	Max
A	1.05	1.45	0.0413	0.0571
A1	0	0.15	0.0000	0.0059
A2	0.9	1.3	0.0354	0.0512
A3	0.6	0.7	0.0236	0.0276
b	0.25	0.5	0.0098	0.0197
c	0.1	0.23	0.0039	0.0091
D	2.82	3.05	0.1110	0.1201
e1	1.9(TYP)		0.0748(TYP)	
E	2.6	3.05	0.1024	0.1201
E1	1.5	1.75	0.0512	0.0689
e	0.95(TYP)		0.0374(TYP)	
L	0.3	0.6	0.0118	0.0236
L1	0.59(TYP)		0.0232(TYP)	
θ	0	8°	0.0000	8°
c1	0.2(TYP)		0.0079(TYP)	

- The contents of this document will be updated with the product's improvement without prior notice. Please consult our sales staff before using this document to ensure that you are using the latest version.
- The application circuit examples described in this document are only used to indicate the representative use of the product and do not guarantee the design of mass production.
- Please use this product within the limits stated in this document. We will not be responsible for any damage caused by improper use.
- The products described in this document are not allowed to be used in equipment or devices that affect the human body without the written permission of our company, including but not limited to: health equipment, medical equipment, disaster prevention equipment, fuel control equipment, automobile equipment, aviation equipment and vehicle equipment.
- Although our company has always been committed to improving product quality and reliability, semiconductor products have a certain probability of malfunction or wrong work. To prevent personal injury or property damage caused by such accidents, please pay full attention to safety design, for example: Alternate design, fire protection design, and prevention of wrong action design.
- When exporting this product or this document overseas, you should abide by applicable import and export control laws.
- Copying or reprinting part or all of this document in any form without the permission of our company is strictly prohibited.