

SK78LXX Three-terminal Positive Regulator

General Description

SK78LXX is three-terminal positive regulators. One of these regulators can deliver up to 150 mA of output current. The internal limiting and thermal -shutdown features of the regulator make them essentially immune to overload. When used as a replacement for a zener diode-resist or Combination, an effective improvement in output impedance can be obtained, together with lower quiescent current.

Features

- Output Current of 150mA
- Thermal Overload Protection
- Short Circuit Protection
- Output transistor safe area protection
- No external components
- Package: SOT89-3 and TO92
- Output voltage accuracy: tolerance $\pm 5\%$

Block Diagram

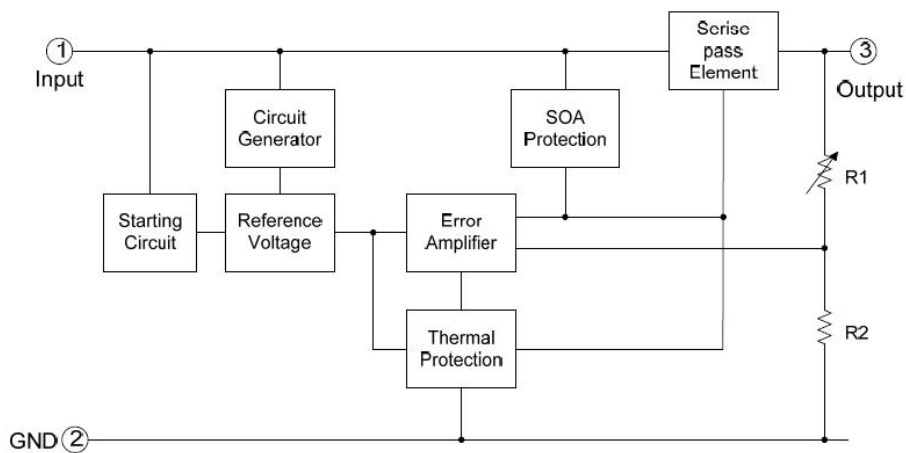

Ordering Information

Part No.	Output Voltage	Package	Tape/Reel
SK78LXX	5.0,6.0,8.0,9.0,12V	SOT89	1000/Reel
SK78LXXTR	5.0,6.0,8.0,9.0,12V	TO92	1000/Reel

Pin Configuration

SOT89 (Top View)

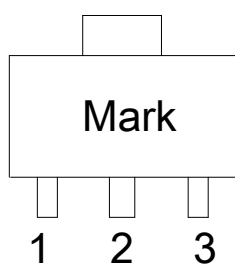

Table1: SK78LXX series (SOT89 PKG)

PIN NO.	PIN NAME	FUNCTION
1	VOUT	Output voltage pin
2	GND	GND pin
3	VIN	Input voltage pin

TO92 (Top View)

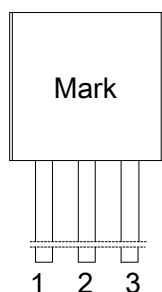

Table3: SK78LXXTR series (TO92 PKG)

PIN NO.	PIN NAME	FUNCTION
1	VOUT	Output voltage pin
2	GND	GND pin
3	VIN	Input voltage pin

Absolute Maximum Ratings (Ta=25°C)

Parameter	Rating	Unit
Input supply voltage: VIN	30	V
MAX. Output current:Iout	100	mA
MAX Power:Pmax	0.5	W
Maximum junction temperature:Tj	-40~125	°C
Storage temperature:Tstr	-55~125	°C
Soldering temperature and time	+260(Recommended 10S)	°C

Note: The absolute maximum ratings are rated values exceeding which the product could suffer physical damage. These values must therefore not be exceeded under any conditions.

Electrical Characteristics

(Cin=0.33uF, Co=0.1uF, 0≤Tj≤125°C, unless otherwise noted)

Parameter	Symbol	Conditions	Min.	Typ.	Max.	Unit
Output Voltage	Vout	Io=40mA, VIN=10V	0.964vout	vout	1.036vout	V
		Io=1mA~40mA VIN=7V~18V	0.96vout	vout	1.04vout	
		Io=1mA~10mA VIN=10V	0.95vout	vout	1.05vout	
Line Regulation	LNR	VIN=7V~18V, Io=20mA	-150	-	150	mV
		VIN=8V~18V, Io=20mA	-100	-	100	
Load Regulation	LDR	VIN=10V, Io=1mA~100mA	-100	-	100	mV
		VIN=10V, Io=1mA~40mA	-30	-	30	
Dropout Voltage	V _{DIF}	Tj=25°C, Io=100mA	-	2	-	V
Output noise Voltage	V _N	F=10Hz to 100KHz	-	40	-	uV/Vo
Ripple Rejection	PSRR	Tj=25°C, f=120Hz, Io=40mA, VIN=8V~20V	-	80	-	dB
Quiescent Current	I _q	VIN=10V, IOU=40mA	-	-	5.5	mA
Quiescent Current Change	ΔI _q	VIN=8V~18V, Io=20mA	-1.5	-	1.5	mA
		VIN=10V, IOU=1mA~40mA,	-0.1	-	0.1	

LNR: Line Regulation. The change in output voltage for a change in the input voltage. The measurement is made under conditions of low dissipation or by using pulse techniques such that the average chip temperature is not significantly affected.

LDR: Load Regulation. The change in output voltage for a change in load current at constant chip temperature.

Typical Performance Characteristics

Output Voltage vs. Input voltage

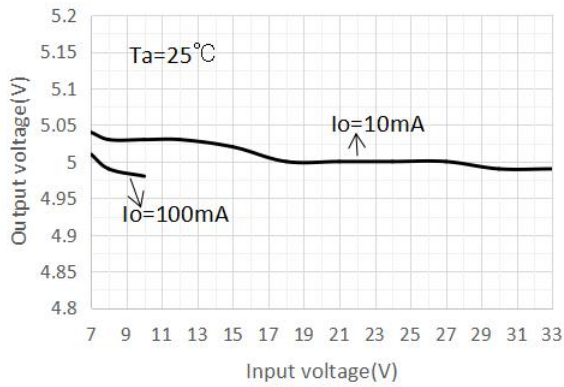

Output Voltage vs. Load

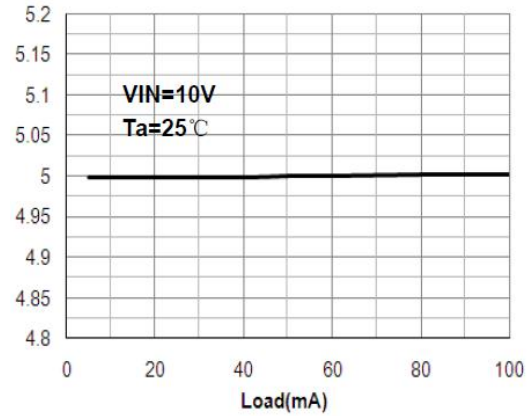

Output voltage vs. Temperature

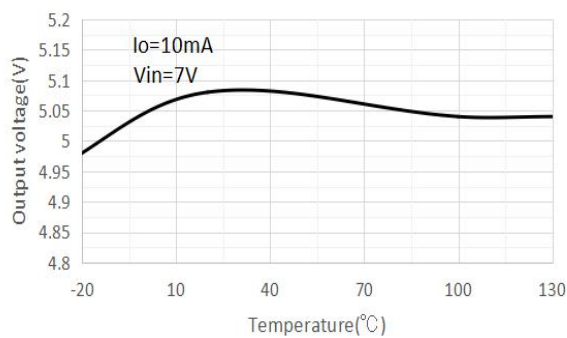

Dropout Voltage vs. Load

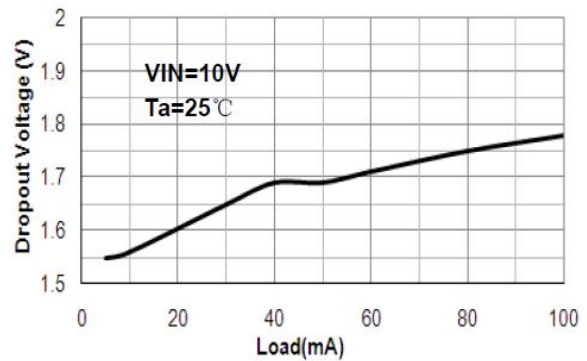

Quiescent current vs. Input voltage

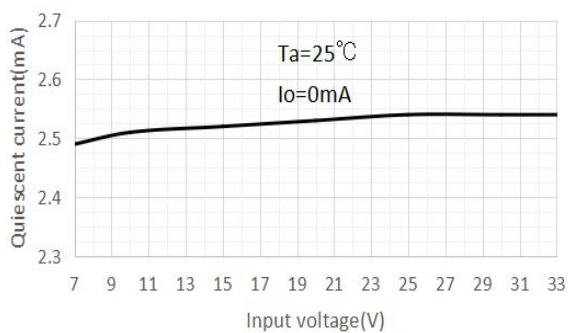

Quiescent Current vs. Load

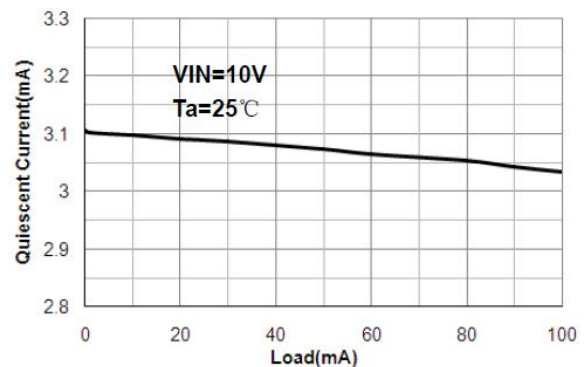

Operation Description

SK78LXX is designed with Thermal Overload Protection that shuts down the circuit when subjected to an excessive power overload condition, Internal Short Circuit Protection that limits the maximum current the circuit will pass, and Output Transistor Safe-Area Compensation that reduces the output short circuit current as the voltage across the pass transistor is increased. In many low current applications, compensation capacitors are not required. However, it is recommended that the regulator input be bypassed with a capacitor if the regulator is connected to the power supply filter with long wire lengths, or if the output load capacitance is large. An input bypass capacitor should be selected to provide good high frequency characteristics to insure stable operation under all load conditions. A 0.33μF or larger tantalum, mylar, or other capacitor having low internal impedance at high frequencies should be chosen. The bypass capacitor should be mounted with the shortest possible leads directly across the regulator's input terminals. Normally good construction techniques should be used to minimize ground loops and lead resistance drops since the regulator has no external sense lead.

Typical Application

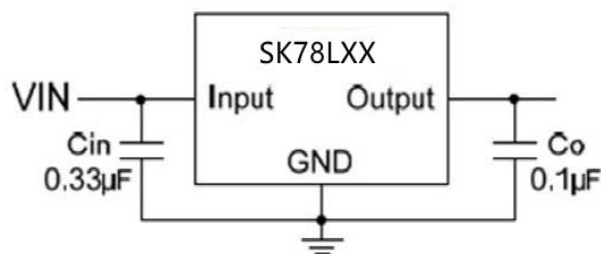

Fig.1 Fixed Output Regulator

A common ground is required between the input and the output voltages. The input voltage must remain typically 2.0 V above the output voltage even during the low point on the input ripple voltage.

- Cin is required if regulator is located an appreciable distance from power supply filter.
- Co is not needed for stability; however, it does improve transient response.

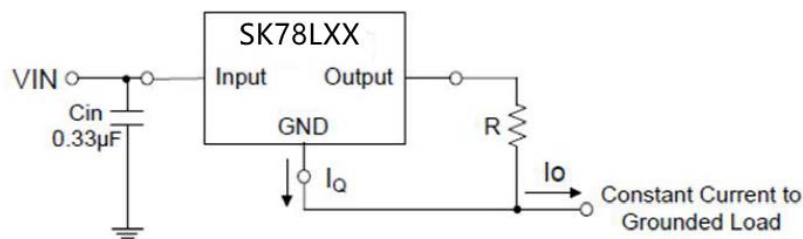

Fig.2 Constant Current Regulator

The SK78LXX regulator can also be used as a current source when connected as Fig.2. In order to minimize dissipation the SK78LXX is chosen in this application. Resistor R determines the current as

follows:
$$I_o = \frac{5V}{R} + I_q$$

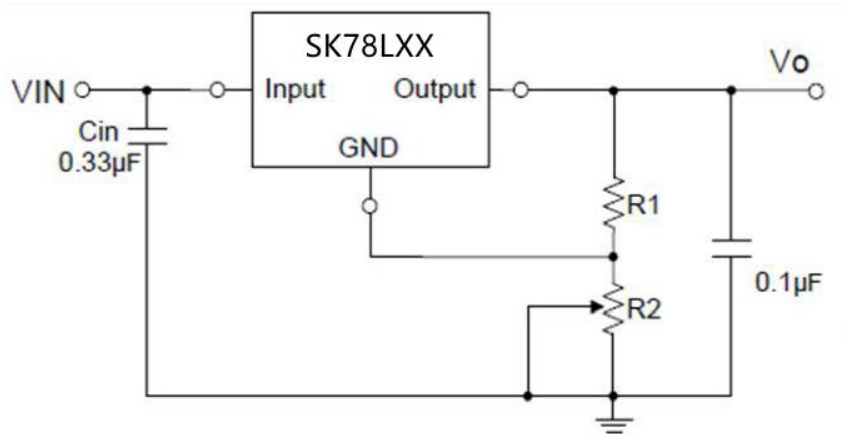

Fig.3 Adjustable Output Regulator

$$V_o = 5V + (5V/R_1 + I_Q) * R_2$$

$$5V/R_1 > 3 * I_Q$$

Package Information

3-pin SOT89 Outline Dimensions

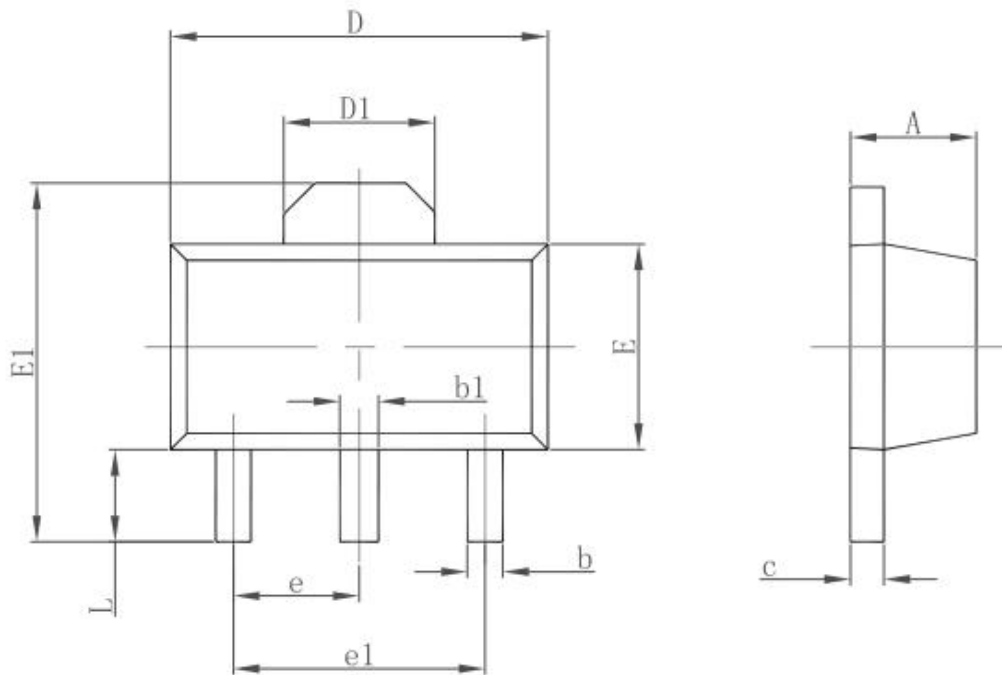

Symbol	Dimensions In Millimeters		Dimensions In Inches	
	Min.	Max.	Min.	Max.
A	1.400	1.600	0.055	0.063
b	0.320	0.520	0.013	0.020
b1	0.400	0.580	0.016	0.023
c	0.350	0.440	0.014	0.017
D	4.400	4.600	0.173	0.181
D1	1.550 REF.		0.061 REF.	
E	2.300	2.600	0.091	0.102
E1	3.940	4.250	0.155	0.167
e	1.500 TYP.		0.060 TYP.	
e1	3.000 TYP.		0.118 TYP.	
L	0.900	1.200	0.035	0.047

3-pin TO92 Outline Dimensions

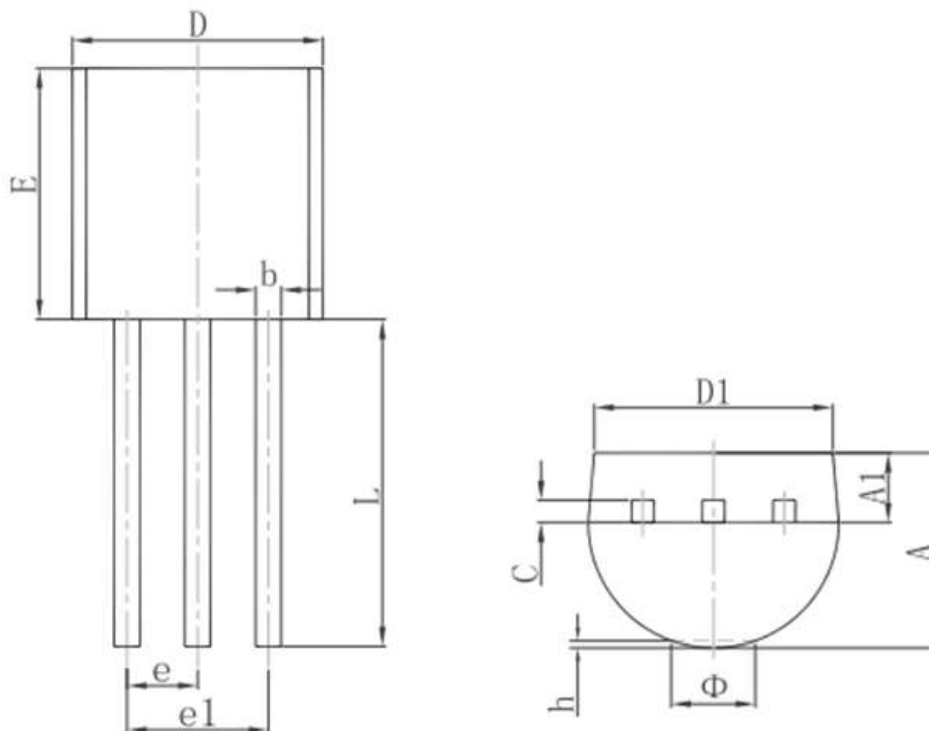

Symbol	Dimensions In Millimeters		Dimensions In Inches	
	Min.	Max.	Min.	Max.
A	3.300	3.700	0.130	0.146
A1	1.100	1.400	0.043	0.055
b	0.380	0.550	0.015	0.022
c	0.360	0.510	0.014	0.020
D	4.300	4.700	0.169	0.185
D1	3.430		0.135	
E	4.300	4.700	0.169	0.185
e	1.270 TYP.		0.050 TYP.	
e1	2.440	2.640	0.096	0.104
L	14.100	14.500	0.555	0.571
Φ		1.600		0.063
h	0.000	0.380	0.000	0.015