



# SGM8262-2

## High Speed, Ultra-Low Noise, Rail-to-Rail Output, High Output Current Amplifier

### GENERAL DESCRIPTION

The SGM8262-2 comprises two voltage feedback operational amplifiers capable of driving heavy loads with excellent linearity and low noise. The low distortion, high output current, and wide output dynamic range make the SGM8262-2 ideal for applications that require a large signal swing into a heavy load.

High speed, rail-to-rail output, low noise, wide bandwidth and fast slew rate of the SGM8262-2 keep distortion to a minimum.

The SGM8262-2 is available in Green SOIC-8 package. It operates over an ambient temperature range of  $-40^{\circ}\text{C}$  to  $+85^{\circ}\text{C}$ .

### APPLICATIONS

Twisted-Pair Line Drivers

Audio Applications

General-Purpose AC Applications

### FEATURES

- Dual Operational Amplifiers
- Voltage Feedback
- High Open-Loop Gain: 130dB
- Unity-Gain Stable
- Support Single or Dual Power Supplies:  
4.5V to 36V or  $\pm 2.25\text{V}$  to  $\pm 18\text{V}$
- Rail-to-Rail Output
- High Linear Output Current:  
150mA Peak into  $16\Omega$  on  $\pm 5\text{V}$  Supplies While  
Maintaining  $-70\text{dBc}$  SFDR
- Ultra-Low Noise:  
4nV/ $\sqrt{\text{Hz}}$  Voltage Noise Density at 1kHz  
4pA/ $\sqrt{\text{Hz}}$  Current Noise Density at 1kHz
- High Speed:  
30MHz Bandwidth ( $G = +1, -3\text{dB}$ )  
40V/ $\mu\text{s}$  Slew Rate ( $R_{\text{LOAD}} = 32\Omega$ )
- $-40^{\circ}\text{C}$  to  $+85^{\circ}\text{C}$  Operating Temperature Range
- Available in Green SOIC-8 Package

**PACKAGE/ORDERING INFORMATION**

MODEL	PACKAGE DESCRIPTION	SPECIFIED TEMPERATURE RANGE	ORDERING NUMBER	PACKAGE MARKING	PACKING OPTION
SGM8262-2	SOIC-8	-40°C to +85°C	SGM8262-2YS8G/TR	SGM 82622YS8 XXXXX	Tape and Reel, 2500

NOTE: XXXXX = Date Code and Vendor Code.

Green (RoHS & HSF): SG Micro Corp defines "Green" to mean Pb-Free (RoHS compatible) and free of halogen substances. If you have additional comments or questions, please contact your SGMICRO representative directly.

**ABSOLUTE MAXIMUM RATINGS**

Supply Voltage..... 38V  
 Junction Temperature..... +150°C  
 Storage Temperature Range..... -65°C to +150°C  
 Lead Temperature (Soldering, 10s)..... +260°C

**RECOMMENDED OPERATING CONDITIONS**

Operating Temperature Range..... -40°C to +85°C

**OVERSTRESS CAUTION**

Stresses beyond those listed may cause permanent damage to the device. Functional operation of the device at these or any other conditions beyond those indicated in the operational section of the specification is not implied. Exposure to absolute maximum rating conditions for extended periods may affect reliability.

**ESD SENSITIVITY CAUTION**

This integrated circuit can be damaged by ESD if you don't pay attention to ESD protection. SGMICRO recommends that all integrated circuits be handled with appropriate precautions. Failure to observe proper handling and installation procedures can cause damage. ESD damage can range from subtle performance degradation to complete device failure. Precision integrated circuits may be more susceptible to damage because very small parametric changes could cause the device not to meet its published specifications.

**DISCLAIMER**

SG Micro Corp reserves the right to make any change in circuit design, specification or other related things if necessary without notice at any time.

**PIN CONFIGURATION**

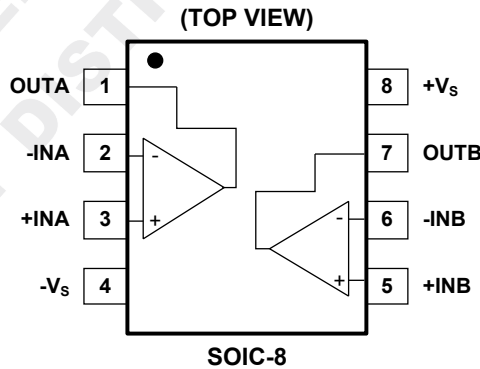

**ELECTRICAL CHARACTERISTICS**(At  $T_A = +25^\circ\text{C}$ ,  $V_S = 4.5\text{V}$  to  $36\text{V}$  or  $V_S = \pm 2.25\text{V}$  to  $\pm 18\text{V}$ ,  $G = +1$ ,  $R_{\text{LOAD}} = 32\Omega$ , unless otherwise noted.)<sup>(1)</sup>

PARAMETER	CONDITIONS	MIN	TYP	MAX	UNITS
<b>DC PERFORMANCE</b>					
Input Offset Voltage ( $V_{\text{OS}}$ )			-500		$\mu\text{V}$
Input Offset Voltage Match			$\pm 100$		$\mu\text{V}$
Input Bias Current ( $I_{\text{B}}$ )			$\pm 40$		nA
Input Offset Current ( $I_{\text{OS}}$ )			$\pm 15$		nA
Open-Loop Voltage Gain ( $A_{\text{OL}}$ )	$V_{\text{OUT}} = \pm 1.0\text{V}$ , $V_S = \pm 2.5\text{V}$		130		dB
	$V_{\text{OUT}} = \pm 2.0\text{V}$ , $V_S = \pm 5\text{V}$		130		dB
	$V_{\text{OUT}} = \pm 3.0\text{V}$ , $V_S = \pm 12\text{V}$		130		dB
<b>INPUT CHARACTERISTICS</b>					
Common Mode Rejection Ratio (CMRR)	$\Delta V_{\text{CM}} = \pm 1\text{V}$		120		dB
<b>OUTPUT CHARACTERISTICS</b>					
+Swing	$R_{\text{LOAD}} = 32\Omega$ , $V_S = \pm 2.5\text{V}$		+2.1		$V_{\text{P}}$
	$R_{\text{LOAD}} = 32\Omega$ , $V_S = \pm 5\text{V}$		+4.2		$V_{\text{P}}$
-Swing	$R_{\text{LOAD}} = 32\Omega$ , $V_S = \pm 2.5\text{V}$		-2.2		$V_{\text{P}}$
	$R_{\text{LOAD}} = 32\Omega$ , $V_S = \pm 5\text{V}$		-4.4		$V_{\text{P}}$
+Swing	$R_{\text{LOAD}} = 100\Omega$ , $V_S = \pm 2.5\text{V}$		+2.3		$V_{\text{P}}$
	$R_{\text{LOAD}} = 100\Omega$ , $V_S = \pm 5\text{V}$		+4.7		$V_{\text{P}}$
	$R_{\text{LOAD}} = 100\Omega$ , $V_S = \pm 12\text{V}$		+11.2		$V_{\text{P}}$
-Swing	$R_{\text{LOAD}} = 100\Omega$ , $V_S = \pm 2.5\text{V}$		-2.4		$V_{\text{P}}$
	$R_{\text{LOAD}} = 100\Omega$ , $V_S = \pm 5\text{V}$		-4.8		$V_{\text{P}}$
	$R_{\text{LOAD}} = 100\Omega$ , $V_S = \pm 12\text{V}$		-11.4		$V_{\text{P}}$
Peak AC Output Current <sup>(2)</sup>	SFDR $\leq -70\text{dBc}$ , $f = 100\text{kHz}$ , $V_S = \pm 5\text{V}$ , $V_{\text{OUT}} = 5V_{\text{P-P}}$ , $R_{\text{LOAD}} = 16\Omega$		150		mA
<b>DYNAMIC PERFORMANCE</b>					
-3dB Bandwidth	$V_{\text{OUT}} = 0.1V_{\text{P-P}}$		30		MHz
0.1dB Flatness	$V_{\text{OUT}} = 0.1V_{\text{P-P}}$		1.4		MHz
Large Signal Bandwidth	$V_{\text{OUT}} = 2.0V_{\text{P-P}}$		5		MHz
Slew Rate (SR)	$V_{\text{OUT}} = 1.0V_{\text{P-P}}$ , $V_S = 5\text{V}$ or $\pm 2.5\text{V}$		40		$\text{V}/\mu\text{s}$
	$V_{\text{OUT}} = 4.0V_{\text{P-P}}$ , $V_S = 10\text{V}$ or $\pm 5\text{V}$		40		$\text{V}/\mu\text{s}$
	$V_{\text{OUT}} = 4.0V_{\text{P-P}}$ , $V_S = 24\text{V}$ or $\pm 12\text{V}$		40		$\text{V}/\mu\text{s}$
<b>NOISE</b>					
Input Voltage Noise Density ( $e_n$ )	$f = 1\text{kHz}$		4		$\text{nV}/\sqrt{\text{Hz}}$
Input Current Noise Density ( $i_n$ )	$f = 1\text{kHz}$		4		$\text{pA}/\sqrt{\text{Hz}}$
<b>POWER SUPPLY</b>					
Supply Voltage Range (Dual Supply)		$\pm 2.25$		$\pm 18$	V
Quiescent Current/Amplifier ( $I_{\text{Q}}$ )			6.2		mA
Power Supply Rejection Ratio (PSRR)	$\Delta V_S = \pm 0.5\text{V}$		-110		dB
<b>AUDIO PERFORMANCE</b>					
Total Harmonic Distortion + Noise (THD+N)	$G = +1$ , $f = 1\text{kHz}$ , $V_{\text{OUT}} = 6V_{\text{P-P}}$ , $V_S = 10\text{V}$ or $\pm 5\text{V}$		0.0004		%
			-108		dB

## NOTES:

- Unity gain used to facilitate characterization. To improve stability, a gain of 2 or greater is recommended.
- Peak AC output current specification assumes normal AC operation and is not valid for continuous DC operation.

## APPLICATION INFORMATION

The SGM8262-2 is a voltage feedback operational amplifier that features rail-to-rail output stage. The SGM8262-2 can operate from a wide supply range,  $\pm 2.25\text{V}$  to  $\pm 18\text{V}$ .

### Power Supply and Decoupling

The SGM8262-2 can be powered with a good quality, well-regulated, low noise supply from  $\pm 2.25\text{V}$  to  $\pm 18\text{V}$ . Pay careful attention to decoupling the power supply. Use high quality capacitors with low equivalent series resistance (ESR), such as multilayer ceramic capacitors (MLCCs), to minimize the supply voltage ripple and power dissipation. Locate a  $0.1\mu\text{F}$  MLCC decoupling capacitor(s) no more than  $1/8$  inch away from the power supply pin(s). A large tantalum  $10\mu\text{F}$  to  $22\mu\text{F}$  capacitor is recommended to provide good decoupling for lower frequency signals and to supply current for fast, large signal changes at the SGM8262-2 outputs.

### Layout Considerations

As with all high speed applications, pay careful attention to printed circuit board (PCB) layout to prevent associated board parasitics from becoming problematic. The PCB should have a low impedance

return path (or ground) to the supply. Removing the ground plane from all layers in the immediate area of the amplifier helps to reduce stray capacitances. The signal routing should be short and direct in order to minimize the parasitic inductance and capacitance associated with these traces. Locate termination resistors and loads as close as possible to their respective inputs and outputs. Keep input traces as far apart as possible from the output traces to minimize coupling (crosstalk) through the board.

When the SGM8262-2 is configured as a differential driver, as in some line driving applications, provide a symmetrical layout to the extent possible in order to maximize balanced performance. When running differential signals over a long distance, the traces on the PCB should be close together or any differential wiring should be twisted together to minimize the area of the inductive loop that is formed. This reduces the radiated energy and makes the circuit less susceptible to RF interference. Adherence to strip line design techniques for long signal traces (greater than approximately 1 inch) is recommended.

PACKAGE OUTLINE DIMENSIONS

SOIC-8

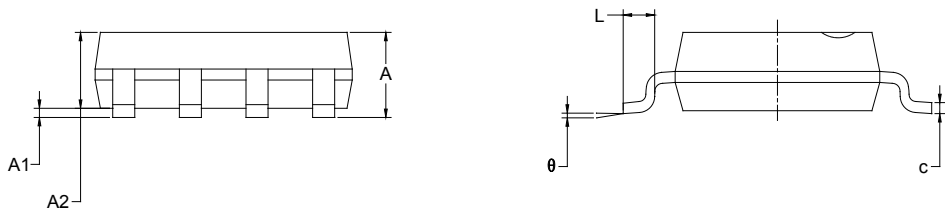
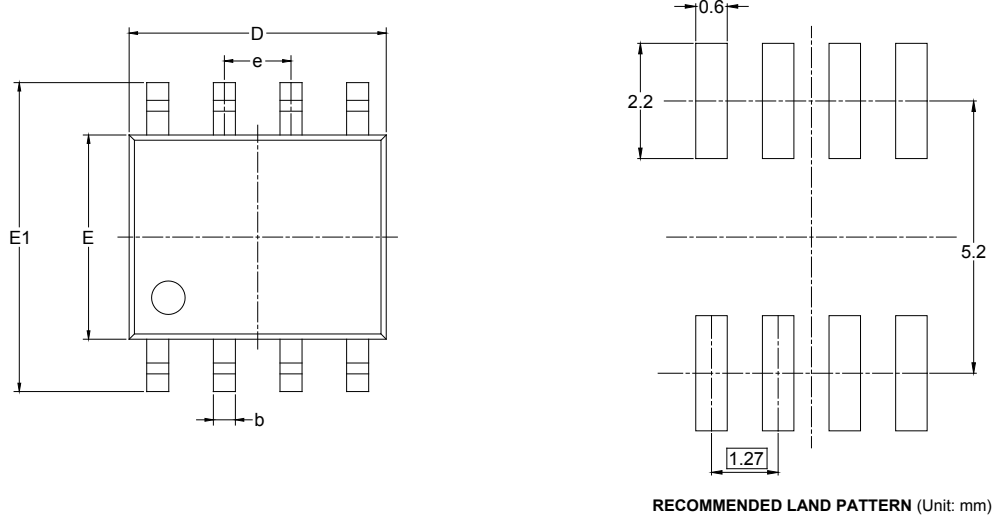

Symbol	Dimensions In Millimeters		Dimensions In Inches	
	MIN	MAX	MIN	MAX
A	1.350	1.750	0.053	0.069
A1	0.100	0.250	0.004	0.010
A2	1.350	1.550	0.053	0.061
b	0.330	0.510	0.013	0.020
c	0.170	0.250	0.006	0.010
D	4.700	5.100	0.185	0.200
E	3.800	4.000	0.150	0.157
E1	5.800	6.200	0.228	0.244
e	1.27 BSC		0.050 BSC	
L	0.400	1.270	0.016	0.050
θ	0°	8°	0°	8°

**TAPE AND REEL INFORMATION**

**REEL DIMENSIONS**

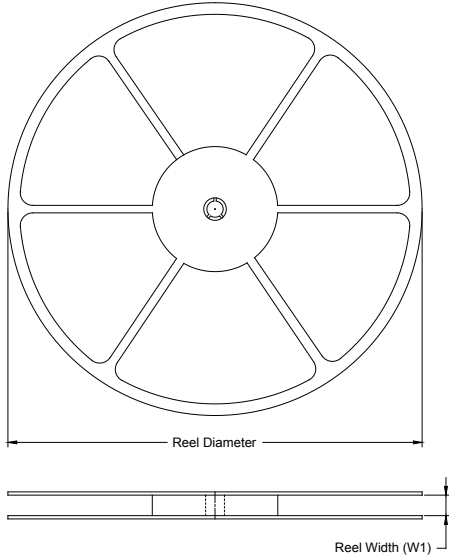

**TAPE DIMENSIONS**

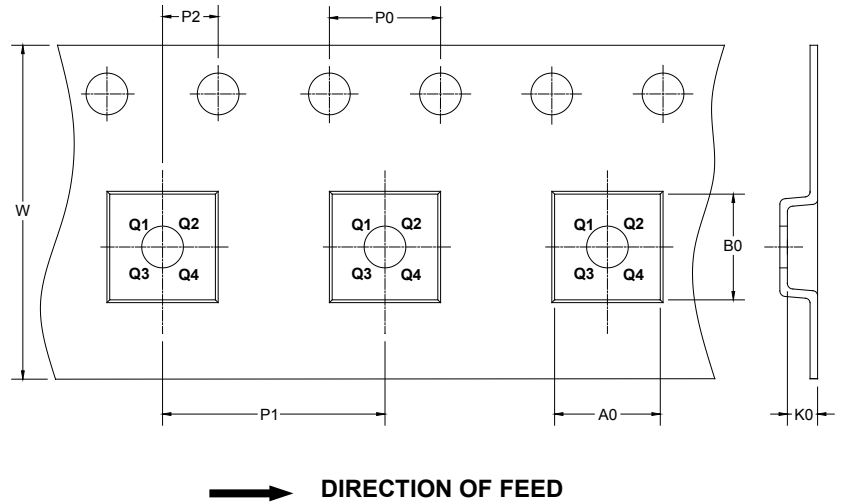

NOTE: The picture is only for reference. Please make the object as the standard.

**KEY PARAMETER LIST OF TAPE AND REEL**

Package Type	Reel Diameter	Reel Width W1 (mm)	A0 (mm)	B0 (mm)	K0 (mm)	P0 (mm)	P1 (mm)	P2 (mm)	W (mm)	Pin1 Quadrant
SOIC-8	13"	12.4	6.4	5.4	2.1	4.0	8.0	2.0	12.0	Q1

000001

# PACKAGE INFORMATION

## CARTON BOX DIMENSIONS

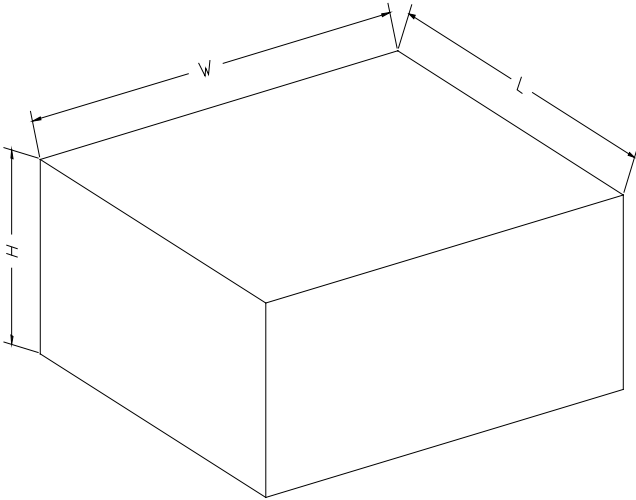

NOTE: The picture is only for reference. Please make the object as the standard.

## KEY PARAMETER LIST OF CARTON BOX

Reel Type	Length (mm)	Width (mm)	Height (mm)	Pizza/Carton
13"	386	280	370	5

DD0002