



SGM42500/SGM42501

3.6A Brushed DC Motor Drivers

GENERAL DESCRIPTION

The SGM42500 and SGM42501 devices are brushed DC motor drivers. Two logic inputs control the H-bridge driver, which consists of four N-MOSFETs that can control motors bi-directionally with up to 3.6A peak current at 40V voltage.

The SGM42500 supports IN1/IN2 PWM interface and the SGM42501 supports PH/EN interface. Internal synchronous rectification control circuitry is provided to lower power dissipation during PWM operation. Customer can adjust PWM current limit or torque in real-time by VREF pin with a controller's DAC output or PWM signal after RC filter.

A number of protection features are provided in the device including over-current, short-circuit, under-voltage lockout, and thermal shutdown. When the fault condition is removed, the device automatically resumes normal operation.

The SGM42500 and SGM42501 are available in a Green SOIC-8 (Exposed Pad) package. They operate over an ambient temperature range of -40°C to $+125^{\circ}\text{C}$.

FEATURES

- H-Bridge Motor Driver
- Wide 6.5V to 40V Operating Voltage Range
- Low On-Resistance: 0.43Ω (HS + LS) at $+25^{\circ}\text{C}$
- 3.6A Peak Current Drive
- Interface
 - ◆ SGM42500: IN1/IN2
 - ◆ SGM42501: PH/EN
- Adjustable PWM Current Limit in Real-Time
- Low Power Standby Mode
- Integrated Protection Features
 - ◆ Over-Current Protection (OCP)
 - ◆ Under-Voltage Lockout (UVLO)
 - ◆ Thermal Shutdown (TSD)
 - ◆ Auto-Retry
- Available in a Green SOIC-8 (Exposed Pad) Package

APPLICATIONS

Printers
Vacuum Cleaners Robotics
Industrial Pumps and Valves

TYPICAL APPLICATION

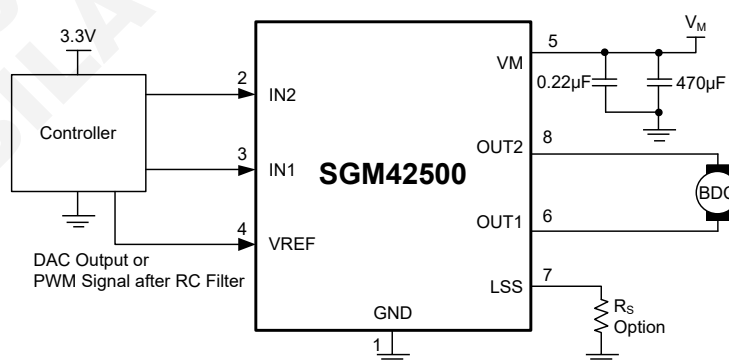

Figure 1. Typical Application Circuit

PACKAGE/ORDERING INFORMATION

MODEL	PACKAGE DESCRIPTION	SPECIFIED TEMPERATURE RANGE	ORDERING NUMBER	PACKAGE MARKING	PACKING OPTION
SGM42500	SOIC-8 (Exposed Pad)	-40°C to +125°C	SGM42500XPS8G/TR	SGM 42500XPS8 XXXXX	Tape and Reel, 4000
SGM42501	SOIC-8 (Exposed Pad)	-40°C to +125°C	SGM42501XPS8G/TR	SGM 42501XPS8 XXXXX	Tape and Reel, 4000

MARKING INFORMATION

NOTE: XXXXX = Date Code, Trace Code and Vendor Code.

XXXXX



Green (RoHS & HSF): SG Micro Corp defines "Green" to mean Pb-Free (RoHS compatible) and free of halogen substances. If you have additional comments or questions, please contact your SGMICRO representative directly.

ABSOLUTE MAXIMUM RATINGS

Power Supply Voltage	50V
EN, PH, IN1, IN2.....	6V
VREF	5V
LSS.....	±500mV
Junction Temperature	+150°C
Storage Temperature Range.....	-65°C to +150°C
Lead Temperature (Soldering, 10s)	+260°C

RECOMMENDED OPERATING CONDITIONS

Power Supply Voltage	6.5V to 40V
Junction Temperature Range	-40°C to +150°C
Ambient Temperature Range.....	-40°C to +125°C

OVERSTRESS CAUTION

Stresses beyond those listed in Absolute Maximum Ratings may cause permanent damage to the device. Exposure to absolute maximum rating conditions for extended periods may affect reliability. Functional operation of the device at any conditions beyond those indicated in the Recommended Operating Conditions section is not implied.

ESD SENSITIVITY CAUTION

This integrated circuit can be damaged if ESD protections are not considered carefully. SGMICRO recommends that all integrated circuits be handled with appropriate precautions. Failure to observe proper handling and installation procedures can cause damage. ESD damage can range from subtle performance degradation to complete device failure. Precision integrated circuits may be more susceptible to damage because even small parametric changes could cause the device not to meet the published specifications.

DISCLAIMER

SG Micro Corp reserves the right to make any change in circuit design, or specifications without prior notice.

PIN CONFIGURATIONS

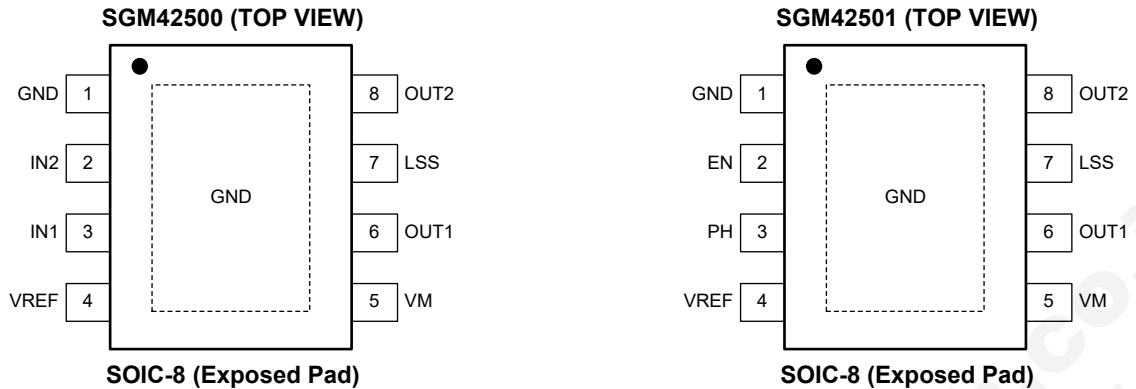

PIN DESCRIPTION

PIN	NAME		TYPE	FUNCTION
	SGM42500	SGM42501		
1	GND	GND	G	Ground.
2	IN2	-	I	Logic Input 2.
	-	EN	I	Enable Input. Logic low to place the H-bridge in brake mode or coast mode.
3	IN1	-	I	Logic Input 1.
	-	PH	I	Direction Input. Control the direction and speed of the H-bridge.
4	VREF	VREF	I	Analog Input. Analog input to set current limit.
5	VM	VM	P	Supply Voltage.
6	OUT1	OUT1	O	H-Bridge Output 1. Output of H-bridge driving stage.
7	LSS	LSS	O	Power Return. Sense resistor connection (option) or connect to power pad ground directly.
8	OUT2	OUT2	O	H-Bridge Output 2. Output of H-bridge driving stage.
Exposed Pad	GND	GND	-	Exposed Pad. Exposed pad for enhanced thermal dissipation.

NOTE: I: input, O: output, G: ground, P: power for the circuit.

ELECTRICAL CHARACTERISTICS

(T_A = +25°C, unless otherwise noted.)

PARAMETER	SYMBOL	CONDITIONS	MIN	TYP	MAX	UNITS
Power Supply (VM)						
Power Supply Voltage	V _M		6.5		40	V
Power Supply Current	I _{VM}	V _M = 12V		2.3		mA
Standby Mode Supply Current	I _{VMQ}	V _M = 12V		2.9		μA
Logic Level Inputs						
Input Logic Low Voltage	V _{IL}			0.8		V
Input Logic High Voltage	V _{IH}			1.15		V
Input Logic Hysteresis	V _{HYS}			350		mV
Input Logic Low Current	I _{IL}	V _{IN} = 0V		0		μA
Input Logic High Current	I _{IH}	V _{IN} = 3.3V		25		μA
Pull-Down Resistance	R _{PD}	To GND		130		kΩ
Propagation Delay	t _{PD}	INx to OUTx change		0.7		μs
Motor Driver Outputs (OUT1 and OUT2)						
High-side FET On-Resistance	R _{DSON}	V _M = 24V, I _{OUT} = 1A, f _{PWM} = 25kHz		250		mΩ
Low-side FET On-Resistance		V _M = 24V, I _{OUT} = 1A, f _{PWM} = 25kHz		180		mΩ
Body Diode Forward Voltage	V _D	I _{OUT} = 1A		0.8		V
Timing						
Turn-On Time ⁽¹⁾	t _{ON}	V _M > V _{UVLO} with IN1 or IN2 high		150		μs
Crossover Delay	t _{COD}			400		ns
VREF Input Voltage Range	V _{REF}		0		4	V
VREF Current Gain	A _V	V _{REF} /V _{LSS} , V _{REF} = 4V		10		V/V
		V _{REF} /V _{LSS} , V _{REF} = 2.5V		10		V/V
		V _{REF} /V _{LSS} , V _{REF} = 1V		10		V/V
Constant Off-Time	t _{OFF}			25		μs
Standby Timer	t _{ST}	SGM42500: IN1 = IN2 < V _{IN_STANDBY} , 10 × V _{LSS} < V _{REF}		1.15		ms
		SGM42501: EN = 0V, 10 × V _{LSS} < V _{REF}		1.15		ms
Protection Circuits						
VM Under-Voltage Lockout	V _{UVLO}	V _M falls until UVLO triggers		6		V
		V _M rises until operation recovers		6.2		
VM Under-Voltage Hysteresis	V _{HYS}	Rising to falling threshold		200		mV
Over-Current Protection Trip Level	I _{OCP}			4		A
Over-Current Deglitch Time	t _{OCP}			2		μs
Over-Current Retry Time	t _{RETRY}			10		ms
Thermal Shutdown Temperature	T _{SD}			160		°C
Thermal Shutdown Temperature Hysteresis	T _{HYS}			20		°C

NOTE: 1. t_{ON} applies when the device initially powers up, and when it exits standby mode.

PWM CONTROL TIMING DIAGRAM

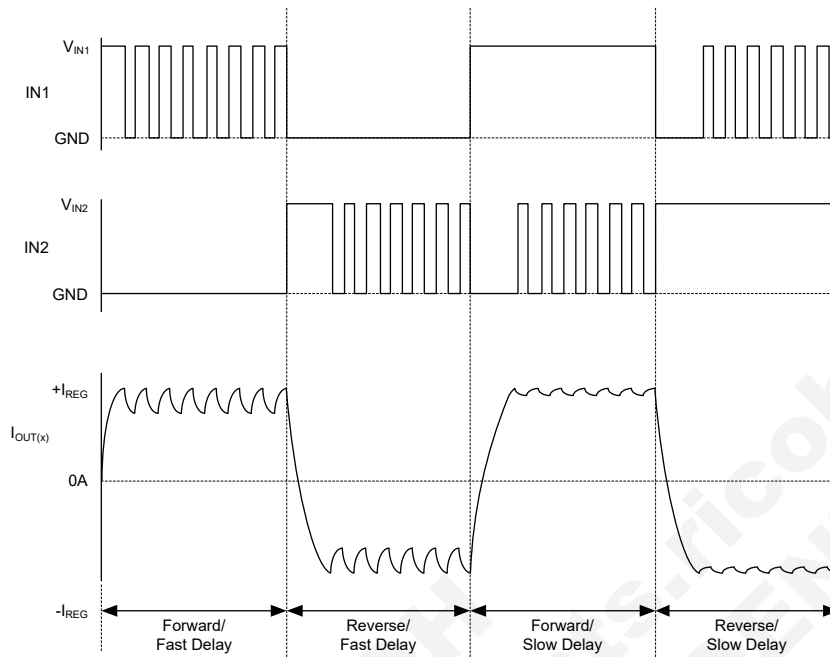

Table 1. SGM42500 PWM Control Truth Table

IN1	IN2	$10 \times V_{LSS} > V_{REF}$	OUT1	OUT2	Function
0	1	False	L	H	Reverse
1	0	False	H	L	Forward
0	1	True	H/L	L	Chop (Mixed Decay), Reverse
1	0	True	L	H/L	Chop (Mixed Decay), Forward
1	1	False	L	L	Brake (Slow Decay)
0	0	False	Z	Z	Coast, enter in the low power standby mode after 1.15ms

Table 2. SGM42501 PH/EN Control Truth Table

PH	EN	$10 \times V_{LSS} > V_{REF}$	OUT1	OUT2	Function
0	1	False	L	H	Reverse
1	1	False	H	L	Forward
0	1	True	H/L	L	Chop (Mixed Decay), Reverse, Adjust Speed
1	1	True	L	H/L	Chop (Mixed Decay), Forward, Adjust Speed
1	0		L	L	Brake (Slow Decay)
0	0		Z	Z	Coast, enter in the low power standby mode after 1.15ms

NOTE: Z = high-impedance.

FUNCTIONAL BLOCK DIAGRAMS

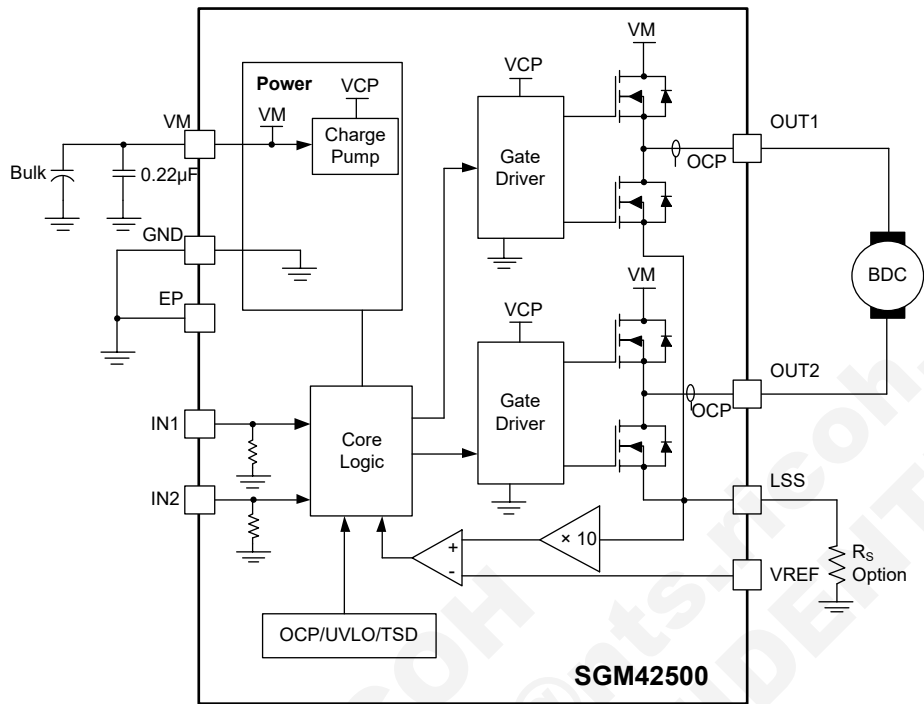

Figure 2. SGM42500 Functional Block Diagram

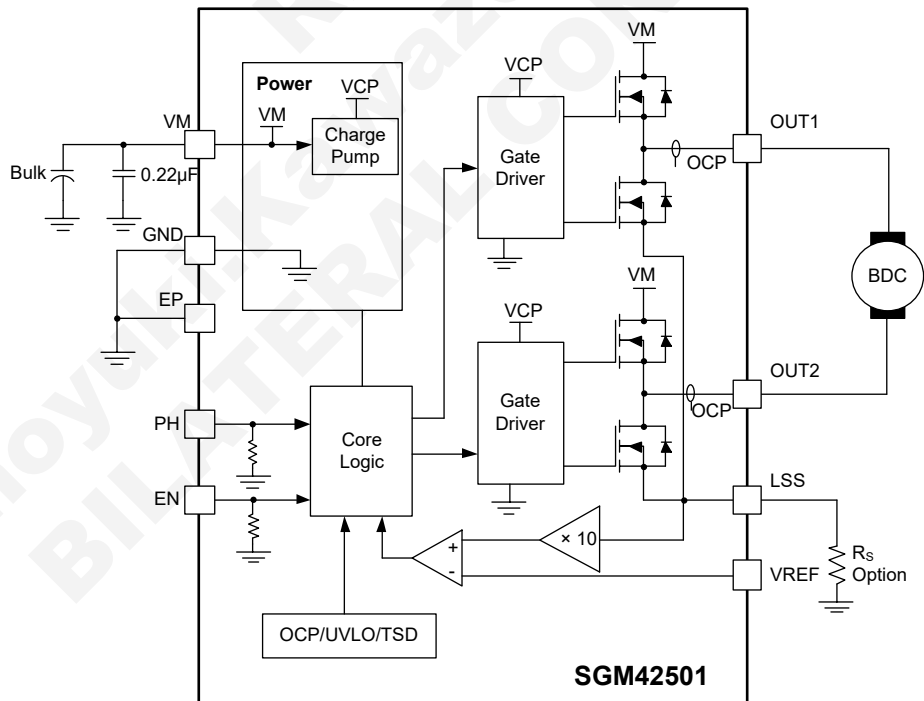

Figure 3. SGM42501 Functional Block Diagram

DETAILED DESCRIPTION

Device Operation

The SGM42500 and SGM42501 are optimized 8-pin devices for driving brushed DC motors with 6.5V to 40V supply voltage and up to 3.6A peak current. The integrated current regulation restricts motor current to a predefined maximum. Two logic inputs control the H-bridge driver, which consists of four N-MOSFETs that have a typical $R_{DS(ON)}$ of 430m Ω (including a high-side FET and a low-side FET). A single power input (V_M), serves as both device power and the motor winding bias voltage. The integrated charge pump of the device boosts V_M internally and fully enhances the high-side FETs. The device has an integrated standby mode that is entered by bringing both inputs low.

Protection circuitry includes internal thermal shutdown, and protection against shorted loads, or against output shorts to ground or supply. Under-voltage lockout prevents damage by keeping the outputs off until the driver has enough voltage to operate normally.

Standby Mode

Low power standby mode of SGM42500 is activated when both input pins (IN1/IN2) are low and $10 \times V_{LSS} < V_{REF}$ for longer than 1.15ms. For SGM42501, low power standby mode is activated when EN pin is low and $10 \times V_{LSS} < V_{REF}$ for longer than 1.15ms. Low power standby mode disables most of the internal circuitry, including the charge pump and the regulator. When the SGM42500 and SGM42501 are coming out of standby mode, the charge pump should be allowed to reach its regulated voltage before any PWM commands are issued to the device.

Internal PWM Current Control

Initially, a diagonal pair of source and sink FET outputs are enabled and current flows through the motor winding and the optional external current sense resistor (R_S). When the voltage across R_S equals the comparator trip value, then the current sense comparator resets the PWM latch. The latch then turns off the sink and source FETs (mixed decay mode).

V_{REF}

The device limits the output current based on the analog input (V_{REF}), and the resistance of an external sense resistor on the LSS pin according to Equation 1:

$$I_{TRIPMAX} = \frac{V_{REF}}{10 \times R_S} \quad (1)$$

where V_{REF} is the input voltage on the V_{REF} pin (V) and R_S is the resistance of the sense resistor (Ω) on the LSS terminal.

Over-Current Protection (OCP)

If the output current exceeds the OCP threshold (I_{OCP}), for longer than t_{OCP} , all FETs in the H-bridge are disabled for a duration of t_{RETRY} . After that, the H-bridge is re-enabled according to the state of the IN1/IN2 or EN/PH pins. If the over-current fault is still present, the cycle repeats, otherwise normal device operation resumes.

Shutdown

If the die temperature increases to approximately +160°C, the H-bridge outputs will be disabled until the internal temperature falls below a hysteresis (T_{HYS}) of 20°C. Internal UVLO is present on V_M to prevent the output drivers from turning on below the UVLO threshold.

Braking

The braking function is implemented by driving the device in slow decay mode, which is done by applying logic high to both inputs, after a bridge enable chop command (see PWM Control Truth Table). Because it is possible to drive current in both directions through the N-MOSFETs, this configuration effectively shorts out the motor generated BEMF, as long as the chop command is asserted. The maximum current can be approximated by V_{BEMF}/R_L . Care should be taken to ensure that the maximum ratings of the device are not exceeded in worse case braking situations: high speed and high inertia loads.

DETAILED DESCRIPTION (continued)

Mixed Decay Operation

The bridges operate in mixed decay mode. Referring to the lower panel of the figure below, as the trip point is reached, the device goes into fast decay mode for 50% of the fixed off-time period. After this fast decay portion, the device switches to slow decay mode for the remainder of the off-time. During transitions from fast

decay to slow decay, the drivers are forced off for the crossover delay (t_{COD}). This feature is added to prevent shoot through in the bridge. During this "dead time" portion, synchronous rectification is not active, and the device operates in fast decay and slow decay only.

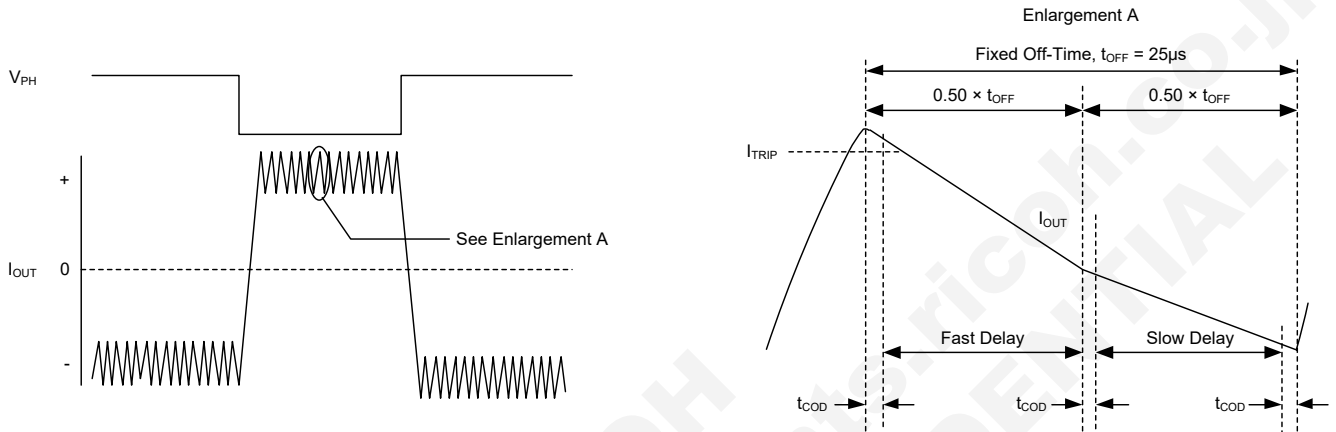

Figure 4. Mixed Decay Mode Operation

APPLICATION INFORMATION

Sense Pin (LSS)

In order to use PWM current control, a low value resistor is placed between the LSS pin and GND for current sensing purposes. To minimize ground trace IR drops in sensing the output current level. For optimal performance, the sense resistor must have the following characteristics:

- ◆ Surface mount
- ◆ Low inductance
- ◆ Rated for high enough power
- ◆ Placed closely to the motor driver

When selecting a value for the sense resistor, make sure not to exceed the maximum voltage on the LSS pin of $\pm 500\text{mV}$ at maximum load. During over-current events, this rating may be exceeded for short durations.

Ground

A star ground should be located as close to the SGM42500/1 as possible. The copper ground plane directly under the exposed pad of the device makes a good location for the star ground point. The exposed pad can be connected to ground for this purpose.

Layout Guidelines

The bulk capacitor should be placed to minimize the distance of the high current path through the motor driver device. The connecting metal trace widths should be as wide as possible, and numerous vias should be used when connecting PCB layers. These practices minimize inductance and allow the bulk capacitor to deliver high current.

Small value capacitors should be ceramic, and placed closely to device pins.

The high current device outputs should use wide metal traces.

The device exposed pad should be soldered to the PCB top layer ground plane. Multiple vias should be used to connect to a large bottom layer ground plane. The use of large metal planes and multiple vias help dissipate the $I^2 \times R_{\text{DS(on)}}$ heat that is generated in the device.

PACKAGE OUTLINE DIMENSIONS

SOIC-8 (Exposed Pad)

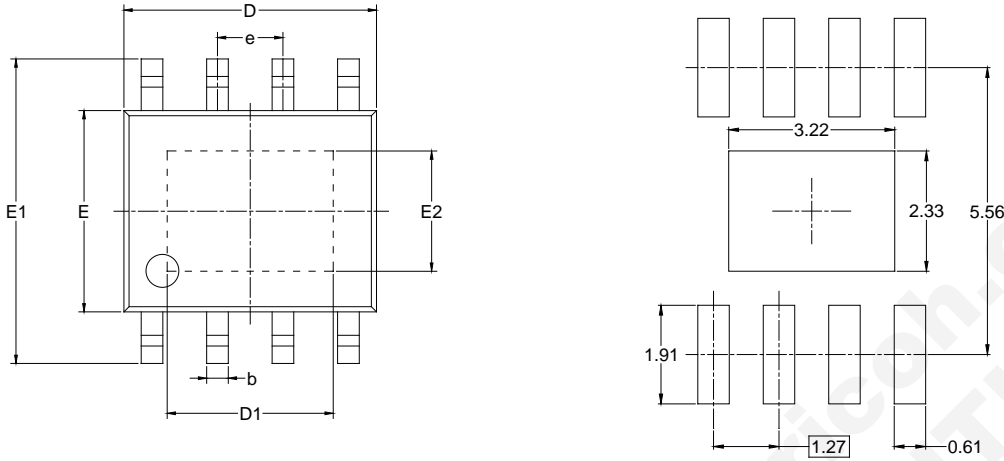

RECOMMENDED LAND PATTERN (Unit: mm)



Symbol	Dimensions In Millimeters		
	MIN	MOD	MAX
A			1.700
A1	0.000	-	0.150
A2	1.250	-	1.650
b	0.330	-	0.510
c	0.170	-	0.250
D	4.700	-	5.100
D1	3.020	-	3.420
E	3.800	-	4.000
E1	5.800	-	6.200
E2	2.130	-	2.530
e	1.27 BSC		
L	0.400	-	1.270
θ	0°	-	8°

NOTES:

1. Body dimensions do not include mode flash or protrusion.
2. This drawing is subject to change without notice.

PACKAGE INFORMATION

TAPE AND REEL INFORMATION

REEL DIMENSIONS

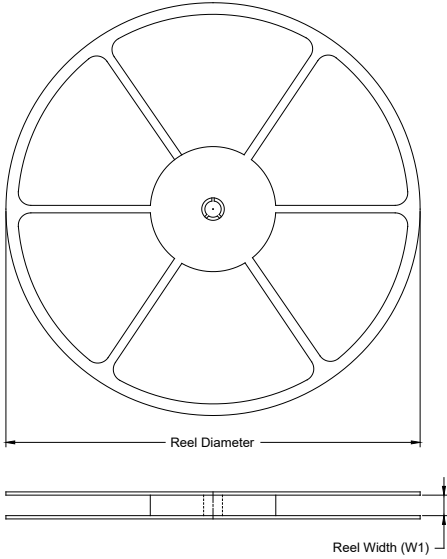

TAPE DIMENSIONS

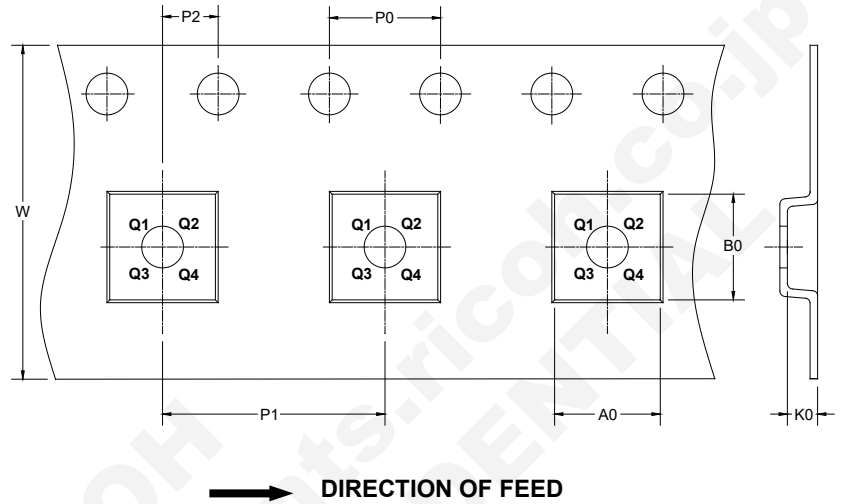

NOTE: The picture is only for reference. Please make the object as the standard.

KEY PARAMETER LIST OF TAPE AND REEL

Package Type	Reel Diameter	Reel Width W1 (mm)	A0 (mm)	B0 (mm)	K0 (mm)	P0 (mm)	P1 (mm)	P2 (mm)	W (mm)	Pin1 Quadrant
SOIC-8 (Exposed Pad)	13"	12.4	6.40	5.40	2.10	4.0	8.0	2.0	12.0	Q1

DD0001

CARTON BOX DIMENSIONS

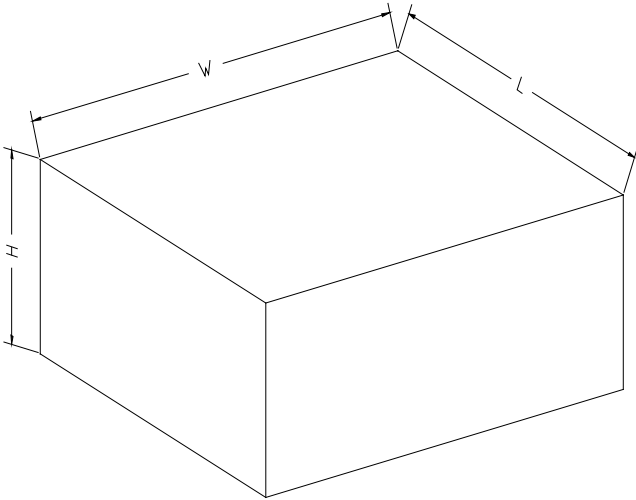

NOTE: The picture is only for reference. Please make the object as the standard.

KEY PARAMETER LIST OF CARTON BOX

Reel Type	Length (mm)	Width (mm)	Height (mm)	Pizza/Carton
13"	386	280	370	5

DD0002