

### General Description

The SY8856 is a high efficiency 3MHz synchronous step down DC/DC regulator capable of delivering up to 4A output current. It operates over a wide input voltage range from 2.7V to 5.5V. It integrates main switch and synchronous switch with very low  $R_{DS(ON)}$  to minimize the conduction loss. High integrated solution and DFN2×2-8 package perform the optimized BOM cost and reduce external component count. Low input and output voltage ripple, small external inductor and capacitor sizes, small PCB layout space are achieved.

### Ordering Information

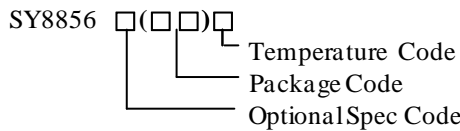

Ordering Number	Package type	Note
SY8856DFC	DFN2×2-8	--

### Features

- Low  $R_{DS(ON)}$  for Internal Switches (Top/Bottom): 35/15 mΩ
- 2.7-5.5V Input Voltage Range
- 3MHz Switching Frequency Minimizes the External Components
- Internal Soft-start Limits the Inrush Current
- Up to 92% Efficiency
- 4A Continuous Output Current Capability
- Shutdown Mode Draws <math><0.1\mu A</math> Supply Current
- 100% Dropout Operation
- Power Good Indicator
- OCP/UVLO/OTP Protections
- RoHS Compliant and Halogen Free
- Compact Package: DFN2×2-8

### Applications

- High definition Set Top Box
- LCD TV
- Notebook PC

### Typical Applications

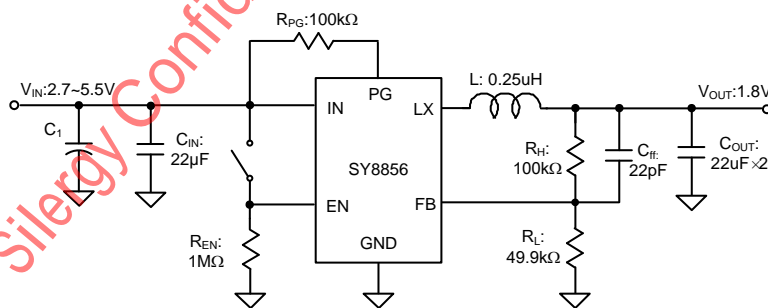

Figure 1. Schematic Diagram

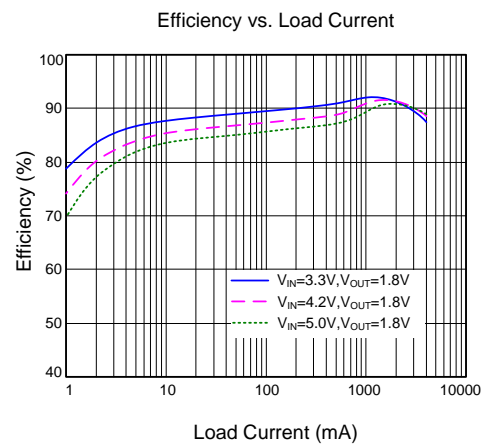
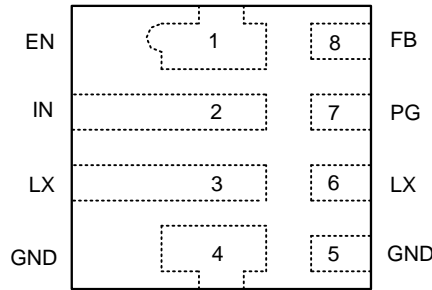

Figure 2. Efficiency vs. Load Current

**Pinout (top view)**



(DFN2x2-8)

**Top Mark:** Gcxyz (device code: Gc, x=year code, y=week code, z=lot number code)

Pin Name	Pin Number	Description
EN	1	Enable control. Pulled high to turn on. Do not leave it floating.
IN	2	Power input pin.
LX	3,6	Inductor pin. Connect this pin to the switching node of the inductor.
GND	4,5	Ground pin.
PG	7	Power good indicator, open drain. When the output voltage exceeds 90% of regulation point, it becomes high, low otherwise.
FB	8	Output feedback pin. Connect this pin to the center point of the output resistor divider (as shown in Figure1) to program the output voltage: $V_{out} = 0.6 \times (1 + R_{H1}/R_{L1})$

**Block Diagram**

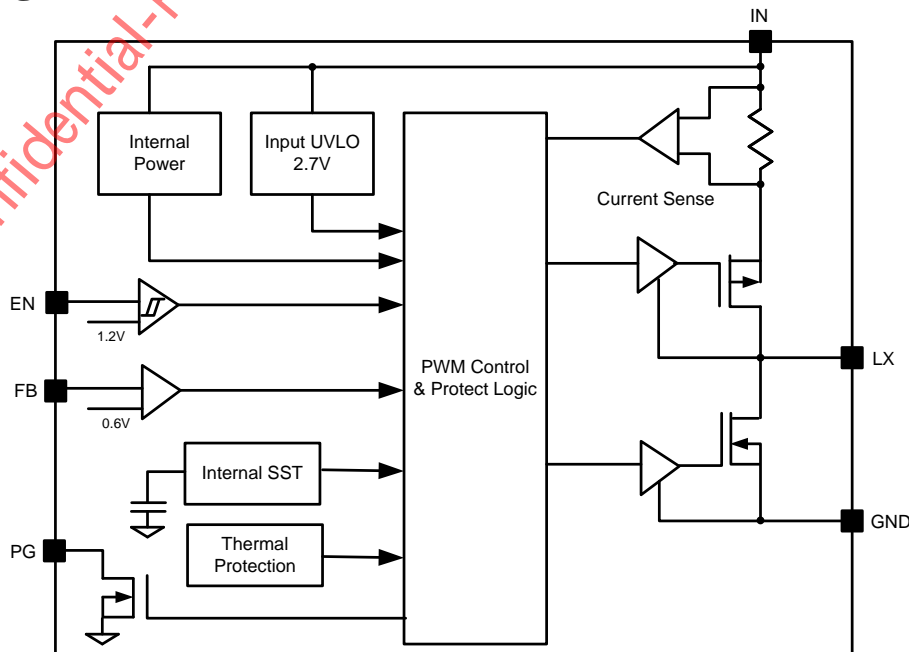

**Figure3. Block Diagram**

**Absolute Maximum Ratings** (Note 1)

IN, LX	-----	6V
All other pins	-----	$V_{IN} + 0.5V$
Power Dissipation, $P_D$ @ $T_A = 25\text{ }^\circ\text{C}$ , DFN2x2	-----	2W
Package Thermal Resistance (Note 2)		
$\theta_{JA}$	-----	62.5 $^\circ\text{C/W}$
$\theta_{JC}$	-----	10 $^\circ\text{C/W}$
Junction Temperature Range	-----	-40 $^\circ\text{C}$ 150 $^\circ\text{C}$
Lead Temperature (Soldering, 10 sec.)	-----	260 $^\circ\text{C}$
Storage Temperature Range	-----	-65 $^\circ\text{C}$ to 150 $^\circ\text{C}$

**Recommended Operating Conditions** (Note 3)

Supply Input Voltage	-----	2.7V to 5.5V
Output Voltage	-----	0.6V to 5V
Junction Temperature Range	-----	-40 $^\circ\text{C}$ to 125 $^\circ\text{C}$
Ambient Temperature Range	-----	-40 $^\circ\text{C}$ to 85 $^\circ\text{C}$

Silergy Confidential-For 半导体芯

## Electrical Characteristics

( $V_{IN} = 5V$ ,  $V_{OUT} = 2.5V$ ,  $L = 0.25\mu H$ ,  $C_{OUT} = 22\mu F \times 2$ ,  $T_A = 25^\circ C$ ,  $I_{OUT} = 1A$  unless otherwise specified)

Parameter	Symbol	Test Conditions	Min	Typ	Max	Unit
Input Voltage Range	$V_{IN}$		2.7		5.5	V
Quiescent Current	$I_Q$	$I_{OUT}=0$ , $EN=1$ , $FB=105\% \times V_{REF}$		60		$\mu A$
Shutdown Current	$I_{SHDN}$	$EN=0$		0.1	1	$\mu A$
Feedback Reference Voltage	$V_{REF}$		0.591	0.6	0.609	V
NFET $R_{DS(ON)}$	$R_{DS(ON)N}$			15		$m\Omega$
PFET $R_{DS(ON)}$	$R_{DS(ON)P}$			35		$m\Omega$
Input Peak Current Limit	$I_{LIM}$		5			A
Internal Soft-start Time	$t_{SS}$			0.8		ms
PGOOD Under-voltage Threshold	$V_{FB,LV}$			0.54		V
Short Circuit Protection Threshold	$V_{SCP}$			0.25		V
Min ON Time				60		ns
Max Duty Cycle			100			%
EN Rising Threshold	$V_{ENH}$		1.2			V
EN Falling Threshold	$V_{ENL}$				0.4	V
Input UVLO Threshold	$V_{UVLO}$				2.7	V
UVLO Hysteresis	$V_{HYS}$			0.3		V
Oscillator Frequency	$f_{OSC}$			3		MHz
Thermal Shutdown Temperature	$T_{SD}$			150		$^\circ C$
Thermal Shutdown Hysteresis	$T_{HYS}$			15		$^\circ C$
LX Node Discharge Resistor	$R_{DSH}$			50		$\Omega$

**Note 1:** Stresses beyond the “Absolute Maximum Ratings” may cause permanent damage to the device. These are stress ratings only. Functional operation of the device at these or any other conditions beyond those indicated in the operational sections of the specification is not implied. Exposure to absolute maximum rating conditions for extended periods may affect device reliability.

**Note 2:**  $\theta_{JA}$  is measured in the natural convection at  $T_A = 25^\circ C$  on 20Z four-layer Silergy evaluation board of JEDEC 51-3 thermal measurement standard. Paddle of DFN2 $\times$ 2-8 package is the case position for  $\theta_{JC}$  measurement.

**Note 3:** The device is not guaranteed to function outside its operating conditions.

**DFN2×2-8 Package Outline**

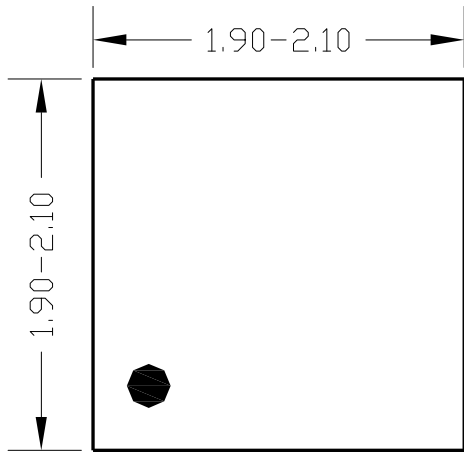

**Top View**

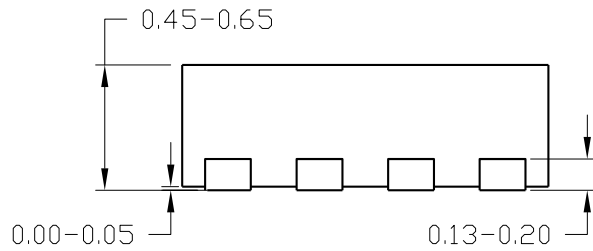

**Side View**

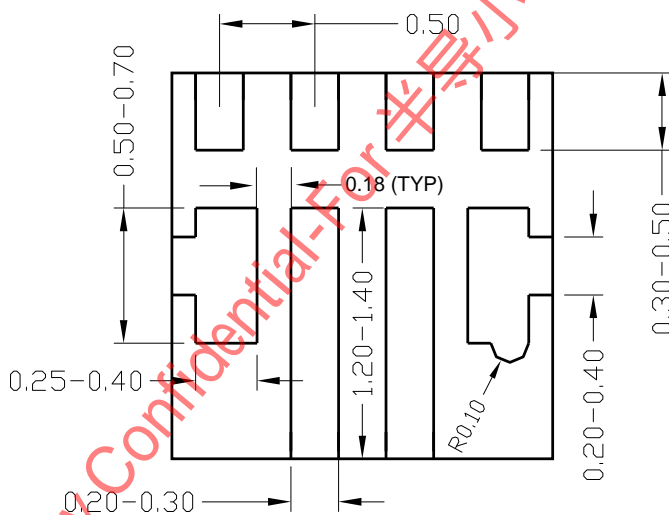

**Bottom View**

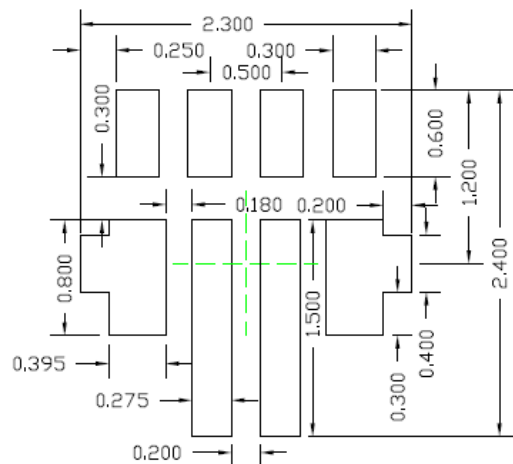

**Recommended PCB**

**Notes:** All dimension in millimeter  
All dimension do not include mold flash & metal burr

## Taping & Reel Specification

### 1. DFN2×2

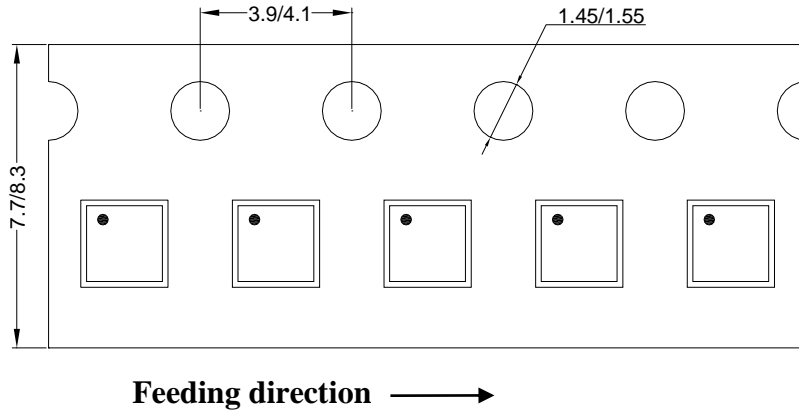

### 2. Carrier Tape & Reel specification for packages

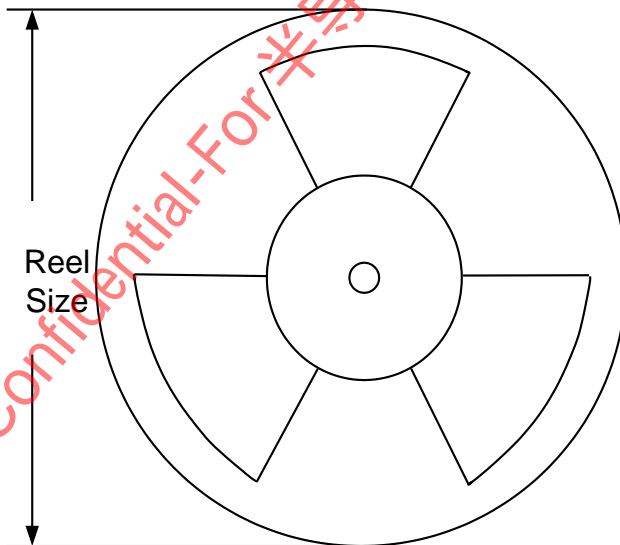

Package types	Tape width (mm)	Pocket pitch(mm)	Reel size (Inch)	Trailer length(mm)	Leader length (mm)	Qty per reel
DFN2×2	8	4	7"	400	160	3000

### 3. Others: NA