

WS7854QA

0.1GHz – 3GHz SP4T Antenna Switch

<http://www.sh-willsemi.com>

Descriptions

The WS7854QA is a single-pole, four-throw (SP4T) switch. The device is optimized for 3G/4G routing and diversity applications. The high linearity performance and low insertion loss make the device an ideal choice for WCDMA/LTE handset and data card applications. The WS7854QA is provided in a compact Quad Flat No-lead Package (QFN) 1.1 x 1.1 mm² package.

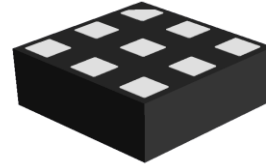

QFN 1.1X1.1-9L (Bottom view)

Features

- Small, low profile package 1.1mm x 1.1mm x 0.55mm
- Working frequency up to 3GHz
- Very low insertion loss
- Excellent isolation performance
- Low power consumption
- Exceptional linearity performance for WCDMA/LTE application
- Low harmonic generation
- Very good ESD performance

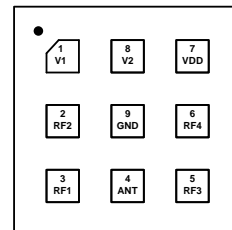

Pin configuration (Top view)

Applications

- Cell phones
- Tablets
- Other RF front-end modules

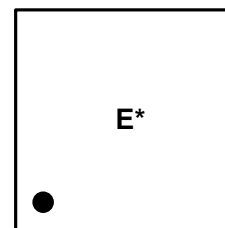

E = Device code
* = Month code (A~Z)

Marking (Top view)

Order information

Device	Package	Shipping
WS7854QA-9/TR	QFN 1.1X1.1-9L	3000/Reel&Tape

Pinning information

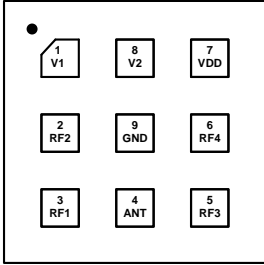
Pin	Function	Description	Transparent top view
1	V1	DC control voltage 1	
2	RF2	RF port 2	
3	RF1	RF port 1	
4	ANT	RF common (antenna) port	
5	RF3	RF port 3	
6	RF4	RF port 4	
7	VDD	DC power supply	
8	V2	DC control voltage 2	
9	GND	Ground	

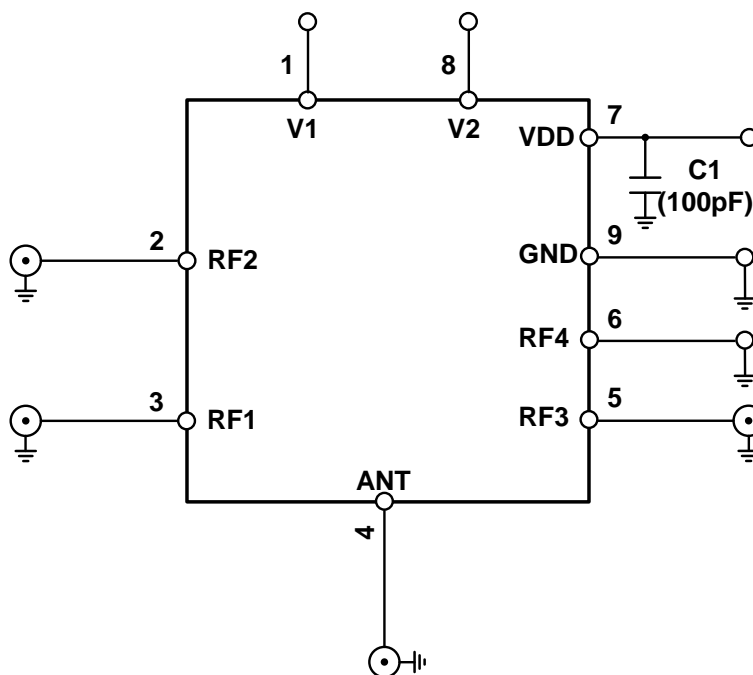
Application information

Note: filter capacitor is needed on VDD

Recommended operating conditions

Parameters	Conditions	Specifications			Unit
		Min.	Typ.	Max.	
ESD Rating					
ESD All Pins	HBM, JESD22-A114	-1000		+1000	V
	CDM	-500		+500	V
Power Supply					
Power Supply Voltage	Operating Voltage	2.5	3.3	4.5	V
Power Supply Current	VDD ≤ 3.3V		50	65	μA
Control Voltage					
Logic Control "Low"		0	0	0.3	V
Logic Control "High"		1.2	1.8	4.5	V
RF Impedance					
RF Port Input and Output Impedance			50		Ω

Absolute maximum ratings

Maximum ratings are absolute ratings, exceeding only one of these values may cause irreversible damage to the integrated circuit.

Items	Value	Unit
VDD Voltage	0 to +5.0	V
Control Voltage	0 to +5.0	V
Maximum Input Power @ RF ports 50Ω, CW, +25°C	33@0.7GHz to 2.7GHz	dBm
Operation Temperature	-40 to +85	°C
Storage Temperature	-65 to +150	°C

Characteristics (RF spec)

Normal test condition unless otherwise stated. All unused ports are 50Ω terminated.

VDD=2.8V, Temp=+25°C. P_{IN}=0dBm.

Parameters	Conditions	Specifications			Unit
		Min.	Typ.	Max.	
Insertion Loss (RF1/RF2/RF3/RF4)	0.1GHz to 1.0GHz 1.0GHz to 2.0GHz 2.0GHz to 2.7GHz		0.25 0.30 0.35		dB
Isolation (ANT to RF1/RF2/RF3/RF4)	0.1GHz to 1.0GHz 1.0GHz to 2.0GHz 2.0GHz to 2.7GHz		33 29 24		dB
Input Return Loss (ANT to RF1/RF2/RF3/RF4)	0.1GHz to 1.0GHz 1.0GHz to 2.0GHz 2.0GHz to 2.7GHz		28 25 25		dB
Second Harmonics (RF1/RF2/RF3/RF4)	0.7GHz to 1.0GHz, P _{IN} =+25dBm 1.0GHz to 2.0GHz, P _{IN} =+25dBm 2.0GHz to 2.7GHz, P _{IN} =+25dBm		86		dBc
Third Harmonics (RF1/RF2/RF3/RF4)	0.7GHz to 1.0GHz, P _{IN} =+25dBm 1.0GHz to 2.0GHz, P _{IN} =+25dBm 2.0GHz to 2.7GHz, P _{IN} =+25dBm		95		dBc
0.1dB Compression Point (RF1/RF2/RF3/RF4)	0.7GHz to 2.7GHz		33		dBm
Turn-On Switching Time	50% of final control voltage to 90% of final RF power, switching between RF ports		0.5		μs

Truth Table for Operation

Mode	V1	V2
RF1	0	1
RF2	1	0
RF3	1	1
RF4	0	0

Note: Any state other than that described in this table places the switch into an undefined state. An undefined state will not damage the device.

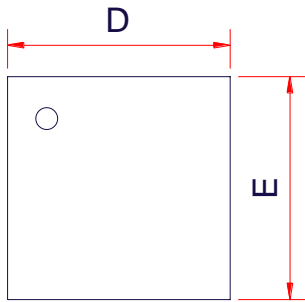
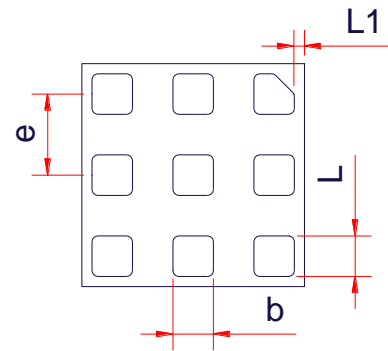
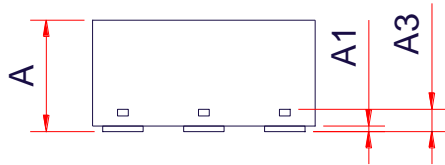
PACKAGE OUTLINE DIMENSIONS
QFN1111-9L

TOP VIEW

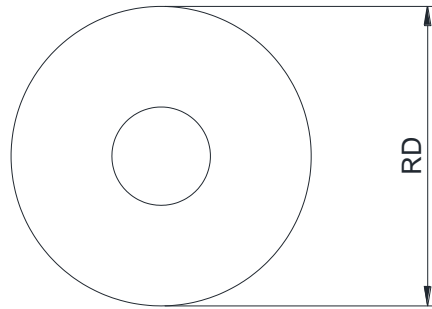
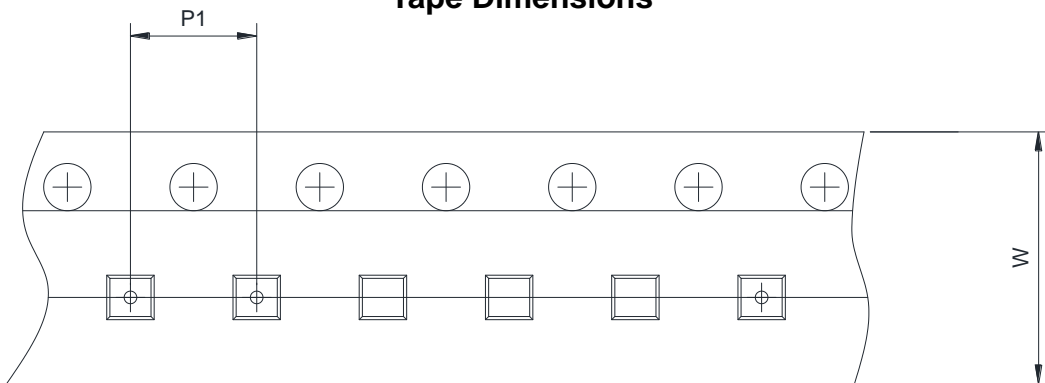
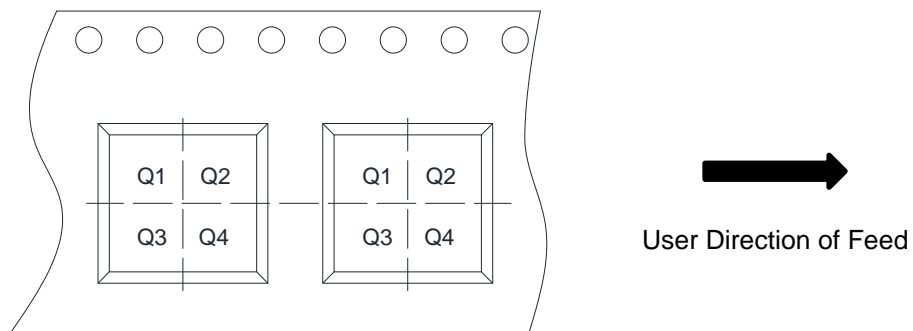
BOTTOM VIEW

SIDE VIEW

Symbol	Dimensions in Millimeters		
	Min.	Typ.	Max.
A	0.50	0.55	0.60
A1	-	0.02	0.05
A3	0.11Ref		
b	0.15	0.20	0.25
D	1.10BSC		
E	1.10BSC		
e	0.40BSC		
L	0.15	0.20	0.25
L1	0.05Ref		

TAPE AND REEL INFORMATION
Reel Dimensions

Tape Dimensions

Quadrant Assignments For PIN1 Orientation In Tape

RD	Reel Dimension	<input checked="" type="checkbox"/> 7inch	<input type="checkbox"/> 13inch		
W	Overall width of the carrier tape	<input checked="" type="checkbox"/> 8mm	<input type="checkbox"/> 12mm		
P1	Pitch between successive cavity centers	<input type="checkbox"/> 2mm	<input checked="" type="checkbox"/> 4mm	<input type="checkbox"/> 8mm	
Pin1	Pin1 Quadrant	<input checked="" type="checkbox"/> Q1	<input type="checkbox"/> Q2	<input type="checkbox"/> Q3	<input type="checkbox"/> Q4