



CONSTANT VOLTAGE AND CONSTANT CURRENT CONTROLLER PL4313

General Description

The PL4313 is a highly integrated solution for a constant voltage/constant current mode SMPS application.

The PL4313 contains one 1.21V voltage reference with $\pm 1\%$ accuracy, one current sensing circuit and two operational amplifiers. Combining the voltage reference with one operational amplifier makes PL4313 an ideal voltage controller for use in adapters and battery chargers. The other low voltage reference combined with the other operational amplifier makes it an ideal current limiter for output low side current sensing.

The PL4313 is available in SOT-23-6 package.

Features

- Constant Voltage and Constant Current Control
- Precision Internal Voltage Reference
- Few External Components
- Easy Compensation
- Low Supply Current: 0.5mA
- Operating Temperature Range: -40 to 105°C

Applications

- Adapters
- Battery Chargers

**Pin Configuration**

Figure 2. Pin Configuration of PL4313 (Top View)

Pin Description

Pin Number	Pin Name	Function
1	V_{CTRL}	Input pin of the voltage control loop
2	GND	Ground
3	V_{OUT}	Output pin. Sinking current only
4	I_{CTRL}	Input pin of the current control loop
5	V_{SENSE}	Input pin of the current control loop
6	V_{CC}	Power supply

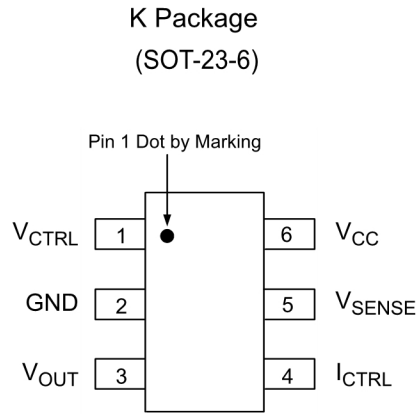

Functional Block Diagram

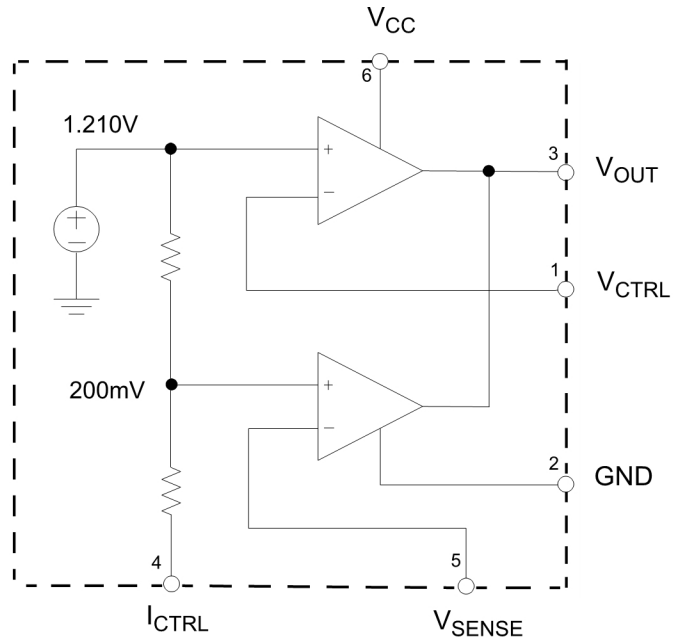

Figure 3. Functional Block Diagram of PL4313

**CONSTANT VOLTAGE AND CONSTANT CURRENT CONTROLLER****PL4313****Absolute Maximum Ratings (Note 1)**

Parameter	Symbol	Value	Unit
Power Supply Voltage	V_{CC}	20	V
Input Voltage	V_{IN}	-0.3 to V_{CC}	V
Junction Temperature	T_J	150	°C
Storage Temperature	T_{STG}	-65 to 150	°C
Lead Temperature (Soldering, 5sec)	T_{LEAD}	260	°C
Package Thermal Resistance (Junction to Case)	θ_{JC}	92	°C/W

Note 1: Stresses greater than those listed under "Absolute Maximum Ratings" may cause permanent damage to the device. These are stress ratings only, and functional operation of the device at these or any other conditions beyond those indicated under "Recommended Operating Conditions" is not implied. Exposure to "Absolute Maximum Ratings" for extended periods may affect device reliability.

Recommended Operating Conditions

Parameter	Symbol	Min	Max	Unit
Power Supply Voltage	V_{CC}	2.5	18	V
Operating Temperature Range	T_A	-40	105	°C



CONSTANT VOLTAGE AND CONSTANT CURRENT CONTROLLER PL4313

Electrical Characteristics

($V_{CC}=5V$, $T_A=25^{\circ}C$, unless otherwise specified.)

Parameter	Symbol	Conditions	Min	Typ	Max	Unit
TOTAL CURRENT CONSUMPTION						
Total Supply Current Not Including the Output Sinking Current	I_{CC}			0.6	1.2	mA
VOLTAGE CONTROL LOOP						
Transduction Gain (V_{CTRL}). Sink Current Only	G_{mv}		1	3.5		mA/mV
Voltage Control Loop Reference	V_{REF}		1.198	1.21	1.222	V
Input Bias Current (V_{CTRL})	I_{IBV}			50		nA
CURRENT CONTROL LOOP						
Transduction Gain (I_{CTRL}).	G_{mi}		1.5	7		mA/mV
Current Control Loop Reference	V_{SENSE}	$I_{OUT}=2.5mA$	196	200	204	mV
Current Out of Pin I_{CTRL} at -200mV	I_{IBI}			25		μA
OUTPUT STAGE						
Low Output Voltage at 10mA Sinking Current	V_{OL}			200		mV
Output Short Circuit Current. Output to V_{CC} . Sink Current Only	I_{OS}			27	50	mA



Typical Performance Characteristics

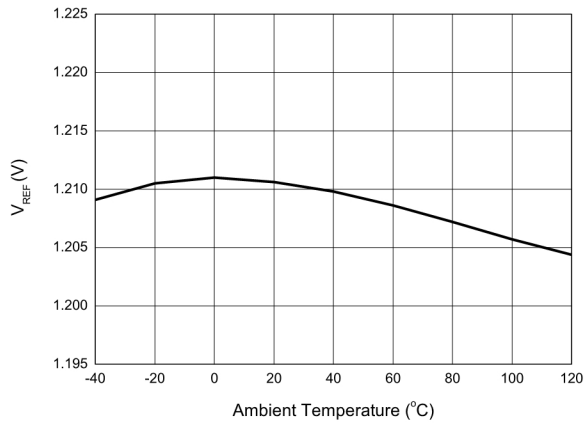

Figure 4. V_{REF} vs. Ambient Temperature

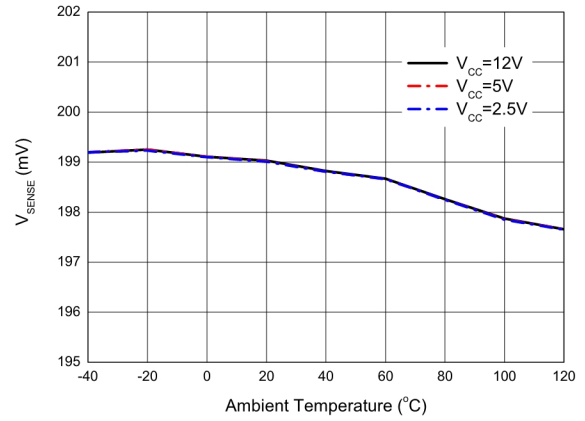

Figure 5. V_{SENSE} vs. Ambient Temperature

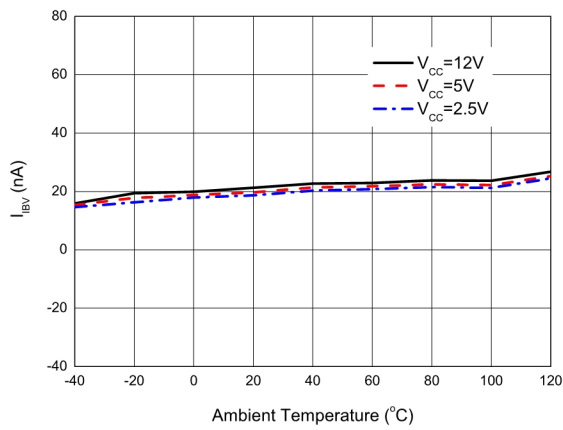

Figure 6. V_{CTRL} Pin Input Bias Current vs. Ambient Temperature

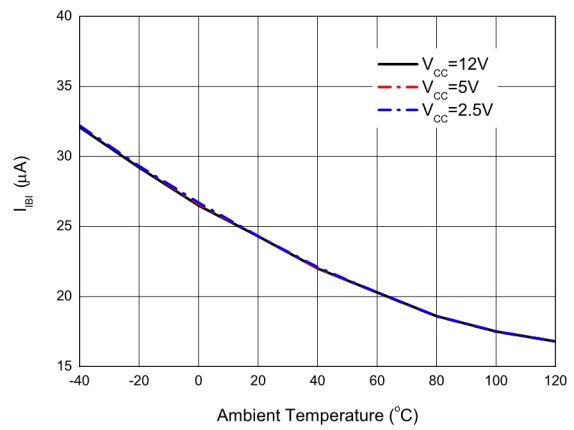

Figure 7. I_{CTRL} Pin Input Bias Current vs. Ambient Temperature



Typical Performance Characteristics (Continued)

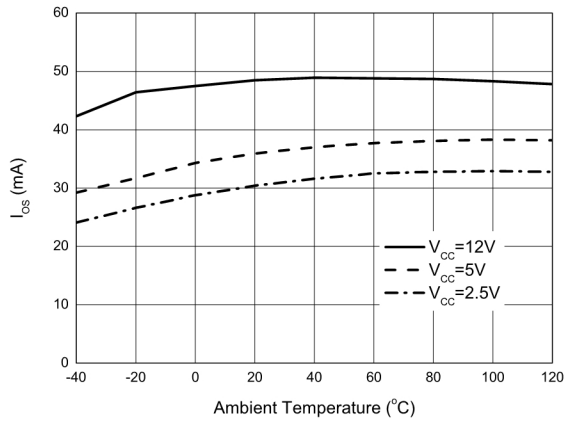

Figure 8. Output Short Circuit Current vs. Ambient Temperature

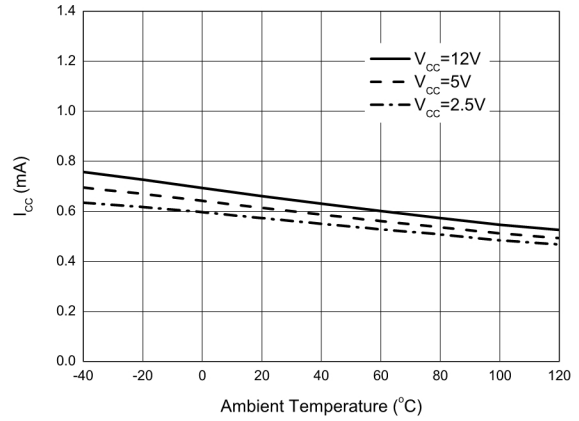
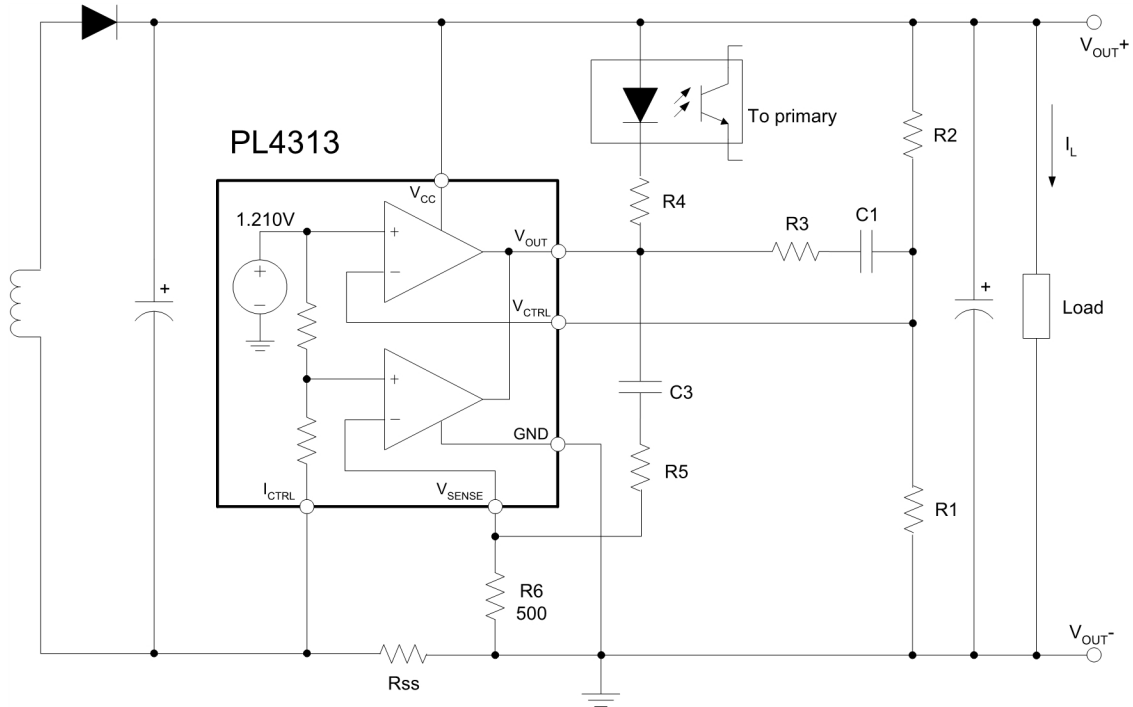

Figure 9. Supply Current vs. Ambient Temperature



CONSTANT VOLTAGE AND CONSTANT CURRENT CONTROLLER PL4313

Typical Application



$$V_{OUT} = V_{REF} \times \frac{R1 + R2}{R1} \quad (V)$$

$$CurrentLimit = \frac{V_{SENSE}}{R_{SS}} \quad (A)$$

Figure 10. Typical Application 1 of PL4313



Typical Application (Continued)

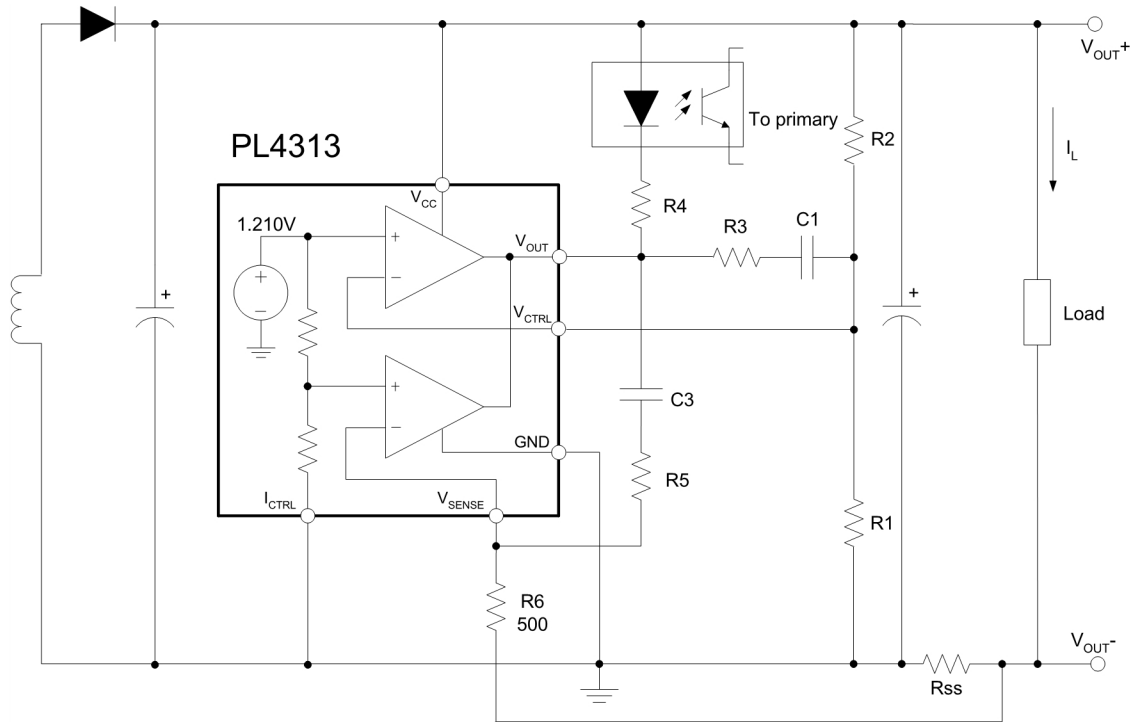

$$V_{OUT} = V_{REF} \times \frac{R1 + R2}{R1} - (I_L \times R_{SS}) \quad (V)$$

$$CurrentLimit = \frac{V_{SENSE} \times V_{REF}}{(V_{SENSE} + V_{REF}) \times R_{SS}} \quad (A)$$

Figure 12. Typical Application 3 of PL4313



CONSTANT VOLTAGE AND CONSTANT CURRENT CONTROLLER PL4313

Mechanical Dimensions

SOT-23-6

Unit: mm(inch)

