

0.6-4GHz SP3T Switch for 3G/4G RX

Features

- Broadband frequency range: 0.6 to 4.0 GHz
- Low insertion loss: 0.35dB typical @ 2.7 GHz
- High isolation: >23dB @ 2.7 GHz
- Integrated logic
- QFN 1.1mm X1.1mm X0.55mm-9L package

Applications

- Cellular 3G/4G RX
- Cellular modems, tablets and USB Devices
- Other RF front-end modules

General Description

The AW13403R is a SP3T switch with low insertion loss and high Isolation. It can be used to support band switching for cellular 3G/4G, data cards and tablets.

The symmetrical design of internal ports makes it convenient for PCB routing and adjustment of receiving and transmitting signals. The band/mode switching is realized by the GPIO pins as referenced in the chip block diagram and the control logic.

The AW13403R is provided in a compact QFN 1.1mm X1.1mm X0.55mm-9L package.

Typical Application Circuit

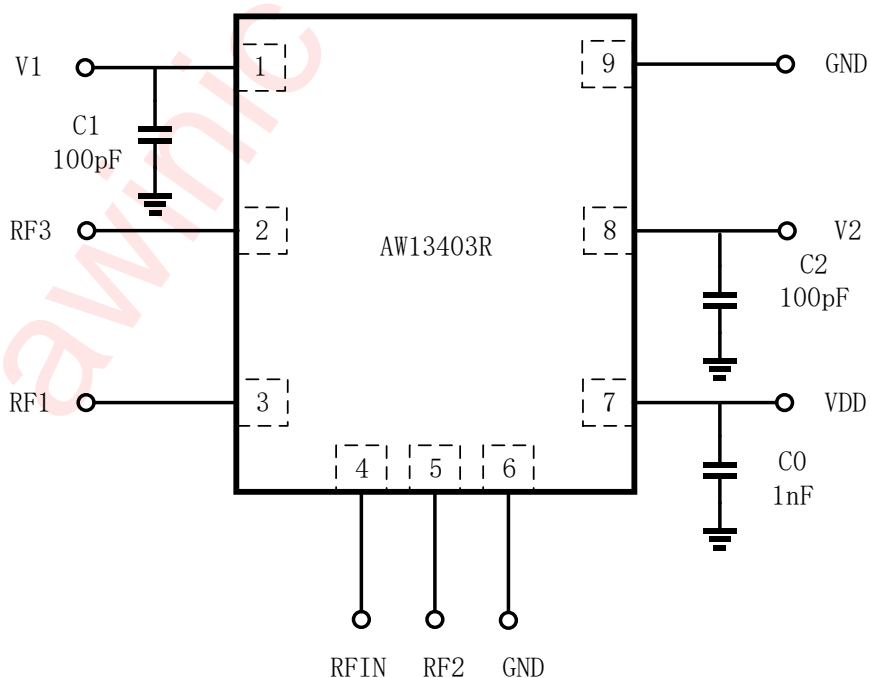

Pin Configuration And Top Mark

AW13403RQNR
(Top View)

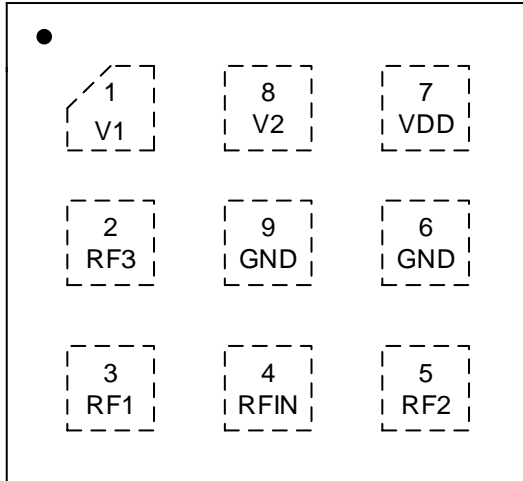

AW13403RQNR Marking
(Top View)

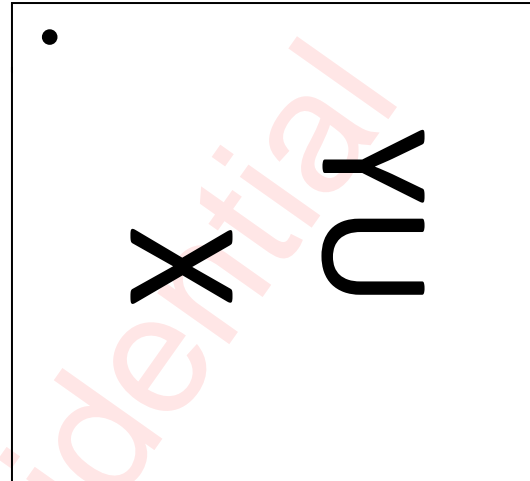

YU - AW13403RQNR

X - Production Tracing Code

Pin Definition

No.	NAME	DESCRIPTION
1	V1	DC Control Voltage 1
2	RF3	RF Port3
3	RF1	RF Port1
4	RFIN	Antenna
5	RF2	RF Port2
6	GND	Ground
7	VDD	Power Supply
8	V2	DC Control Voltage 2
9	GND	Ground

Functional Block Diagram

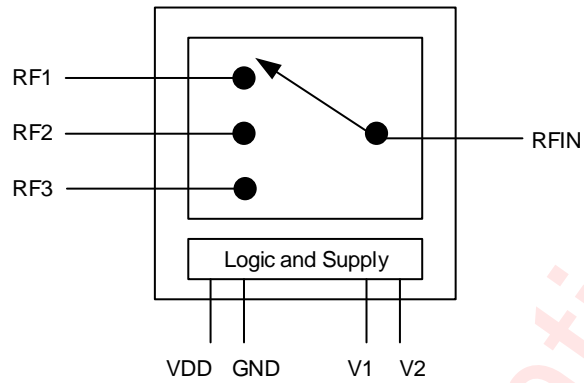

Ordering Information

Part Number	Temperature	Package	Marking	Moisture Sensitivity Level	Environmental Information	Delivery Form
AW13403RQNR	-40℃~85℃	QFN 1.1mm x 1.1mm x 0.55mm-9L	YU	MSL1	ROHS+HF	3000 units/ Tape and Reel

Absolute Maximum Ratings(NOTE1)

PARAMETERS		RANGE
Supply Voltage Range VDD		-0.3V to 3.6V
Control Voltage Range	V1,V2	-0.3V to 3.6V
RF input power(RFIN to RF1/RF2/RF3)		31dBm
Operating Free-air Temperature Range		-40°C to 85°C
Storage Temperature TSTG		-65°C to 150°C
Lead Temperature (Soldering 10 Seconds)		260°C
ESD (NOTE 2)		
HBM		±1000V
CDM		±500V

NOTE1: Conditions out of those ranges listed in "absolute maximum ratings" may cause permanent damages to the device. In spite of the limits above, functional operation conditions of the device should within the ranges listed in "recommended operating conditions". Exposure to absolute-maximum-rated conditions for prolonged periods may affect device reliability.

NOTE2: The human body model is a 100pF capacitor discharged through a 1.5kΩ resistor into each pin. Test method: ESDA/JEDEC JS-001-2017. CDM test method ESDA/JEDEC JS -002-2018.

Electrical Characteristics

VDD=2.8V, V1/V2=0/1.8V, PIN=0dBm, TEMP=+25°C, Z0=50Ω. (unless otherwise noted)

PARAMETER	TEST CONDITION	MIN	TYP	MAX	UNIT	
DC Specifications						
VDD	Supply Voltage	2.4	2.8	3.3	V	
IDD	Supply Current		26	50	μA	
VCTL_H	Control Voltage					
	High	1		VDD	V	
VCTL_L	Low	0		0.3		
T _{sw}	Switching On/Off Time	50% of final control voltage to 10%/90% of final RF power, switching between RF1/2/3		0.3	1	μs
RF Specifications						
IL	Insertion loss(RFIN pin to RF1/RF2/RF3)	0.6-1.0G		0.25	0.39	dB
		1.0-2.0G		0.28	0.45	dB
		2.0-2.7G		0.33	0.52	dB
		2.7-3.8G		0.45	0.59	dB
ISO	Isolation (RFIN pin to RF1/RF2/RF3)	0.6-1.0G	33	38		dB
		1.0-2.0G	27	31		dB
		2.0-2.7G	22	27		dB
		2.7-3.8G	17	21		dB
RL	Input return loss (RFIN pin to RF1/RF2/RF3)	0.6-1.0G	23	31		dB
		1.0-2.0G	20	28		dB
		2.0-2.7G	18	20		dB
		2.7-3.8G	14	17		dB
2fo	Second harmonics (RFIN pin to RF1/RF2/RF3)	PIN=+26dBm, 900MHz		85		dBc
3fo	Third harmonics (RFIN pin to RF1/RF2/RF3)	PIN=+26dBm, 900MHz		88		dBc
P0.1dB	0.1dB Compression Point (RFIN pin to RF1/RF2/RF3)	0.6–3GHz		31		dBm

Detailed Functional Description

It is very important that the user adheres to the correct power-on/off sequence in order to avoid damaging the device. The control signal V1/V2 should be set to 0V unless VDD is set in the operating voltage range.

Power ON:

- 1) Apply voltage supply --- VDD
- 2) Set Controls---V1/V2
- 3) Apply RF input

Change switch position from one RF port to another:

- 1) Remove RF input
- 2) Change control voltages V1/V2 to set the switch to desired RF port
- 3) Apply RF input

Power OFF:

- 1) Remove RF input
- 2) Remove control voltages-V1/V2
- 3) Remove VDD input

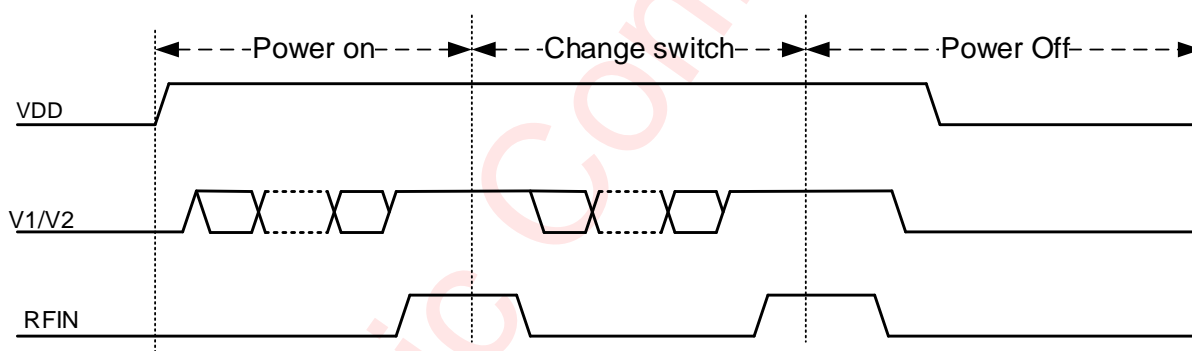

Power on/Change switch/Power off sequence

Control Logic

Control Pins		Switch RF I/O		
V1	V2	RF1	RF2	RF3
0	0	Isolation	Isolation	Isolation
1	0	ON	Isolation	Isolation
0	1	Isolation	ON	Isolation
1	1	Isolation	Isolation	ON

Tape And Reel Information

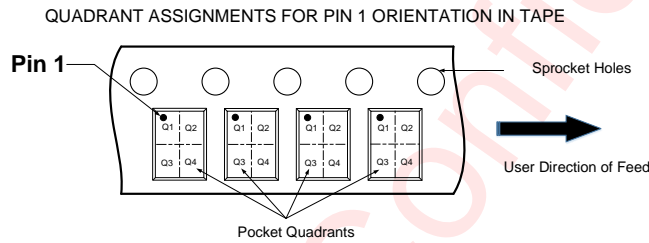
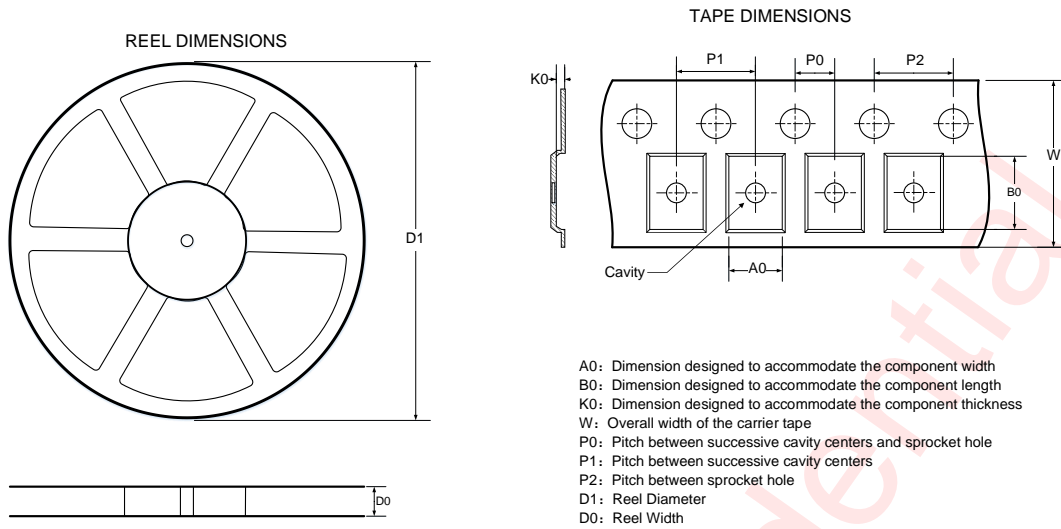

Note: The above picture is for reference only. Please refer to the value in the table below for the actual size

DIMENSIONS AND PIN1 ORIENTATION

D1 (mm)	D0 (mm)	A0 (mm)	B0 (mm)	K0 (mm)	P0 (mm)	P1 (mm)	P2 (mm)	W (mm)	Pin1 Quadrant
178	8.4	1.3	1.3	0.69	2	4	4	8	Q1

All dimensions are nominal

Package Description

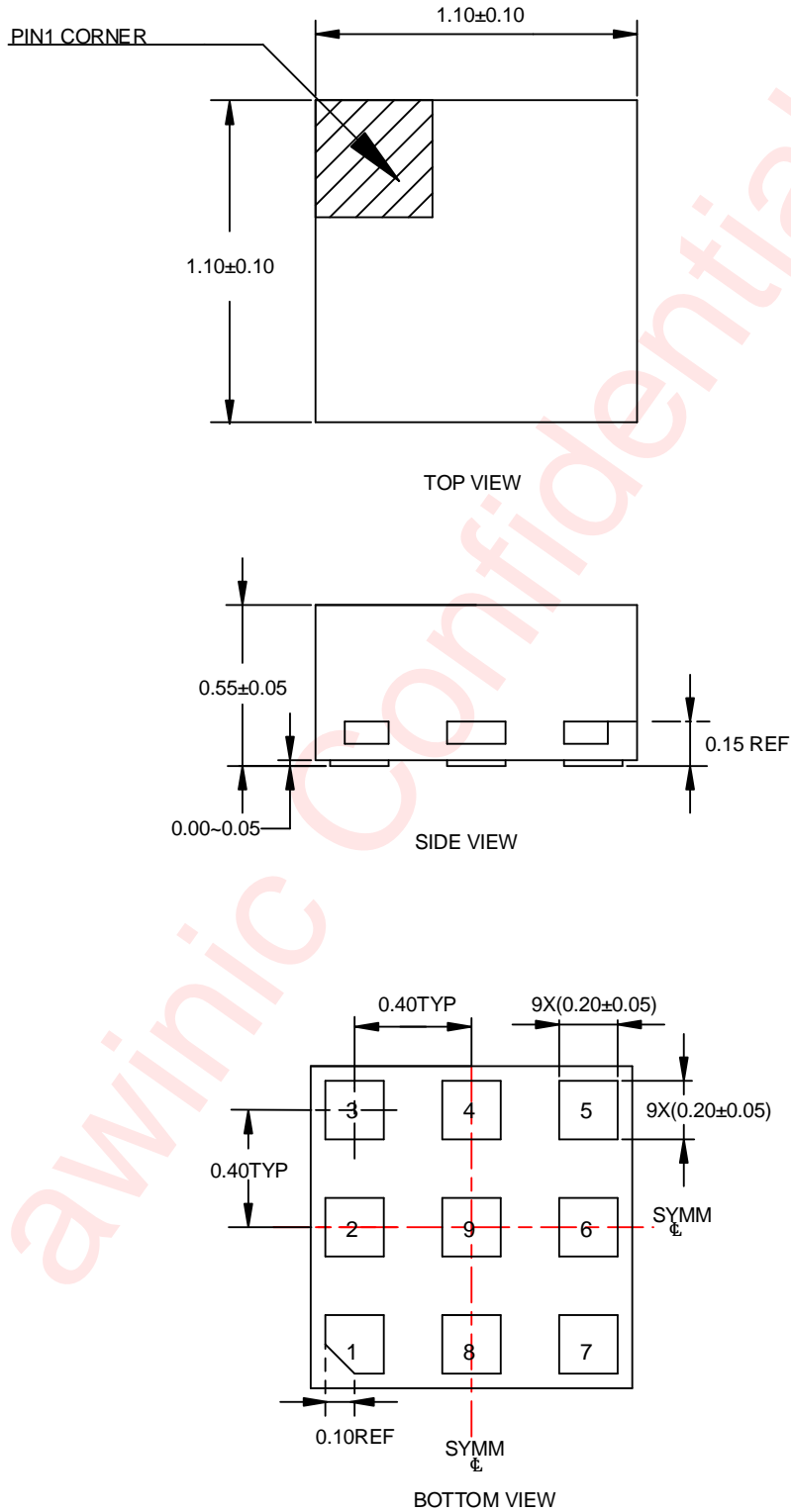

Unit: mm

Land Pattern Data

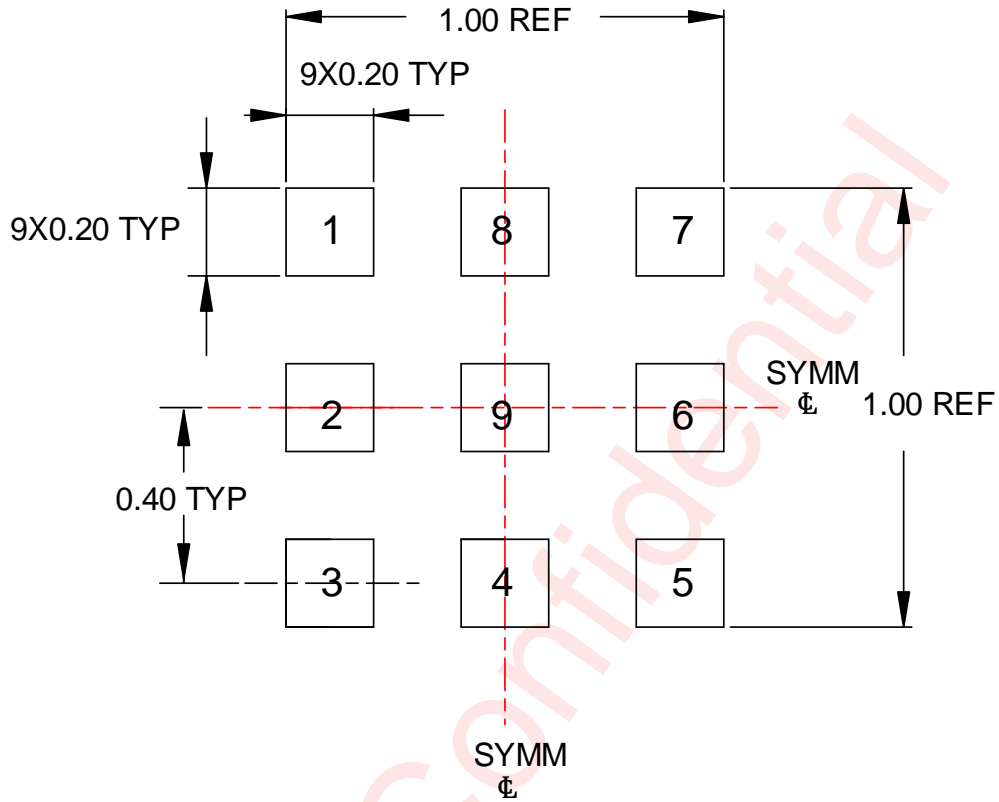

0.05 MAX
All AROUND

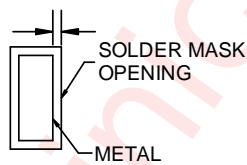

NON SOLDER MASK DEFINED

0.05 MIN
All AROUND

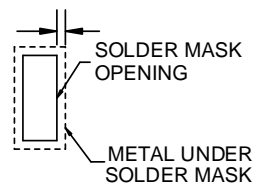

SOLDER MASK DEFINED

Unit: mm

Revision History

Version	Date	Change Record
V1.0	Oct. 2021	Officially Released
V1.1	Aug. 2022	Update ordering information and AMR and Electrical characteristics

awinic Confidential

Disclaimer

All trademarks are the property of their respective owners. Information in this document is believed to be accurate and reliable. However, Shanghai AWINIC Technology Co., Ltd (AWINIC Technology) does not give any representations or warranties, expressed or implied, as to the accuracy or completeness of such information and shall have no liability for the consequences of use of such information.

AWINIC Technology reserves the right to make changes to information published in this document, including without limitation specifications and product descriptions, at any time and without notice. Customers shall obtain the latest relevant information before placing orders and shall verify that such information is current and complete. This document supersedes and replaces all information supplied prior to the publication hereof.

AWINIC Technology products are not designed, authorized or warranted to be suitable for use in medical, military, aircraft, space or life support equipment, nor in applications where failure or malfunction of an AWINIC Technology product can reasonably be expected to result in personal injury, death or severe property or environmental damage. AWINIC Technology accepts no liability for inclusion and/or use of AWINIC Technology products in such equipment or applications and therefore such inclusion and/or use is at the customer's own risk.

Applications that are described herein for any of these products are for illustrative purposes only. AWINIC Technology makes no representation or warranty that such applications will be suitable for the specified use without further testing or modification.

All products are sold subject to the general terms and conditions of commercial sale supplied at the time of order acknowledgement.

Nothing in this document may be interpreted or construed as an offer to sell products that is open for acceptance or the grant, conveyance or implication of any license under any copyrights, patents or other industrial or intellectual property rights.

Reproduction of AWINIC information in AWINIC data books or data sheets is permissible only if reproduction is without alteration and is accompanied by all associated warranties, conditions, limitations, and notices. AWINIC is not responsible or liable for such altered documentation. Information of third parties may be subject to additional restrictions.

Resale of AWINIC components or services with statements different from or beyond the parameters stated by AWINIC for that component or service voids all express and any implied warranties for the associated AWINIC component or service and is an unfair and deceptive business practice. AWINIC is not responsible or liable for any such statements.