

Inductorless, Triple Channel Flash & Indicator 2in1 LED Driver

FEATURES

- Flash and Indicator 2in1 application
- Dual Independent 1.0A LED1/LED2 Current Source
 - Flash: 3.91mA~1.0A, 256 levels
3.91mA/level
 - Torch: 1.46mA~375mA, 256 levels
1.46mA/level
 - Indicator: 0.37mA~375mA, 1024 levels
0.37mA/level
 - Flash Timeout: 40ms~1.6s, 16 levels
- Independent 375 mA LED3 Current Sink
 - Flash: 1.46mA~375mA, 256 levels
1.46mA/level
 - Torch: 1.46mA~375mA, 256 levels
1.46mA/level
 - Indicator: 0.73mA~375mA, 512 levels
0.73mA/level
 - Flash Timeout: 40ms~1.6s, 16 levels
- Optimized Flash LED Current During Low Battery Conditions (IVFM)
- Hardware Strobe Enable (STROBE)
- 400kHz I²C: AW36526 (I²C Address=0x63)
- 0.4mm Pitch, FCQFN-10L Package

APPLICATION

Smartphone Camera Flash

TYPICAL APPLICATION CIRCUIT

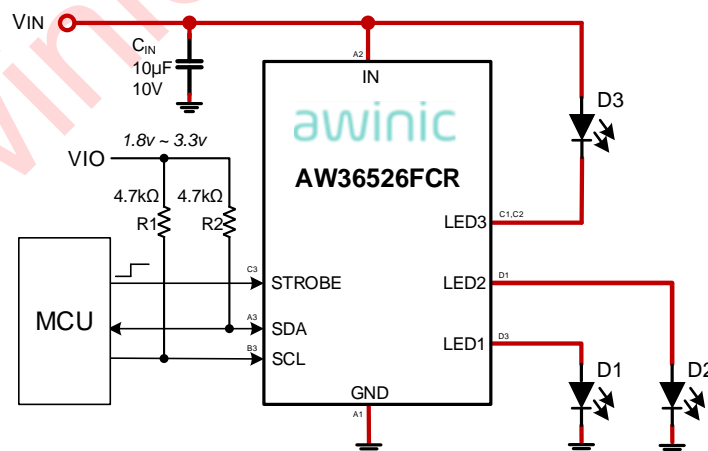

Fig 1 Typical Application Circuit of AW36526

All trademarks are the property of their respective owners.

GENERAL DESCRIPTION

The AW36526 is a inductorless triple channel flash & Indicator 2in1 LED driver that provides a high level of adjustability within a ultra-small solution size. The AW36526 includes two current sources and a current sink which is controlled independently by I²C-compatible interface. The AW36526 provides IVFM protection mode to prevent system reset or shutdown under low battery condition.

The AW36526 is controlled via an I²C-compatible interface. The main features of the AW36526 include: flash / torch / IR / Indicator current, flash timeout duration, IVFM and breath features. The AW36526 also provides hardware flash pin (STROBE) to control flash event.

The device operates over a -40°C to +85°C ambient temperature range.

The AW36526 is available in small 0.4mm pitch 1.6mmx1.2mm FCQFN-10L package.

PIN CONFIGURATION AND TOP MARK

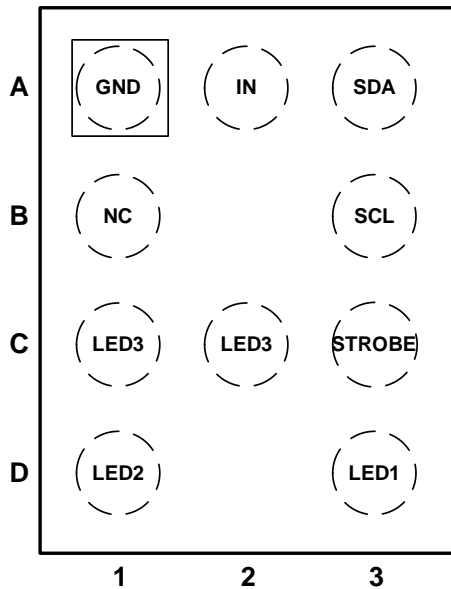
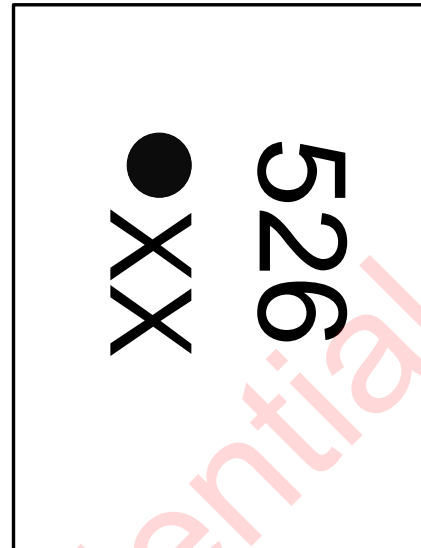
AW36526FCR Pin Configuration
(Top View)AW36526FCR Top Mark
(Top View)

526 – AW36526FCR
XX – Manufacture Tracking Code

Fig 2 Pin Configuration and Top Mark

PIN DEFINITION

| No. | NAME | TYPE | DESCRIPTION |
|-------|--------|--------|---|
| A1 | GND | Ground | Ground |
| A2 | IN | Power | Input voltage connection. Connect IN to GND with a 10 μ F or larger ceramic capacitor. |
| A3 | SDA | I/O | Serial data input/output of the I ² C interface. |
| B1 | NC | I/O | No Connect. Must be floating, for chip test. |
| B3 | SCL | I/O | Serial clock input of the I ² C interface. |
| C1,C2 | LED3 | Power | Low-side current sink output for flash LED3. |
| C3 | STROBE | I/O | Active high hardware flash enable. Drive STROBE high to turn on Flash pulse. Internal pull down resistor of 300k Ω between STROBE and GND. |
| D1 | LED2 | Power | High-side current source output for flash LED2. |
| D3 | LED1 | Power | High-side current source output for flash LED1. |

ORDERING INFORMATION

| Part Number | Temperature | Package | Marking | Moisture Sensitivity Level | Environmental Information | Delivery Form |
|-------------|-------------|-----------|---------|----------------------------|---------------------------|------------------------------|
| AW36526FCR | -40°C~85°C | FCQFN-10L | 526 | MSL1 | ROHS+HF | 3000 units/ Tape and Reel |

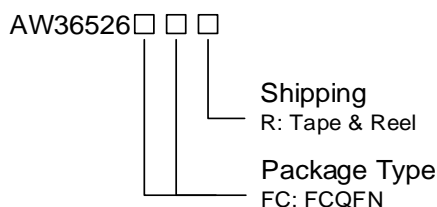

AWINIC FLASH LED DRIVER SERIES

| Product | Channels | Type | Description | Package |
|---------|----------|--------------|--|---------|
| AW3644 | 2 | Boost | High Efficiency, Dual Independent 1.5A Flash LED Driver | CSP-12 |
| AW36414 | 2 | Boost | High Efficiency, Dual Independent 1.5A Flash LED Driver | CSP-12 |
| AW3643 | 2 | Boost | High Efficiency, Dual 1.5A Flash LED Driver | CSP-12 |
| AW36413 | 2 | Boost | High Efficiency, Dual 1.5A Flash LED Driver | CSP-12 |
| AW3648 | 1 | Boost | High Efficiency, 1.5A Flash LED Driver | CSP-12 |
| AW3641E | 1 | Charge Pump | Flash Current & Flash Timer Programmable 1A Flash LED Driver | DFN-10 |
| AW3640 | 1 | Current Sink | 200mA 1-Wire Configurable Front Flash LED Driver | DFN-6 |
| AW36402 | 1 | Current Sink | 200mA 1-wire Configurable Front Flash LED Driver | DFN-6 |
| AW36404 | 1 | Current Sink | 400mA 1-wire Configurable Front Flash LED Driver | DFN-8 |
| AW36406 | 1 | Current Sink | 600mA PWM Configurable Front Flash LED Driver | DFN-8 |

TYPICAL APPLICATION CIRCUITS

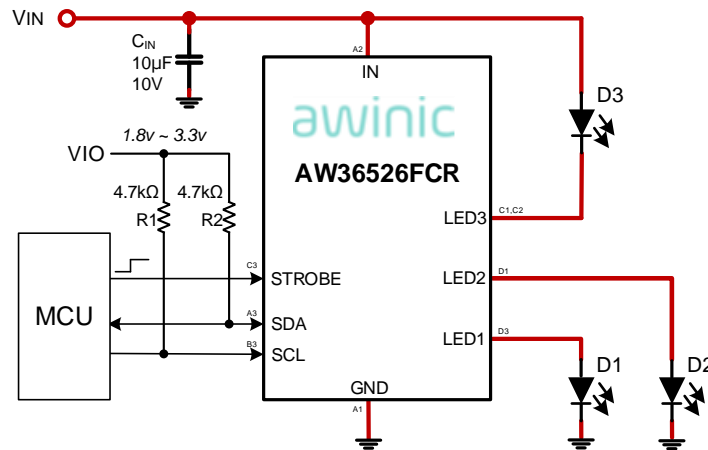

Fig 3 AW36526 Application Circuit

Notice for Typical Application Circuits:

1. Please place C_{IN} as close to the chip as possible.
2. For the sake of driving capability, the power lines, and the connection lines of LED should be short and wide as possible.

ABSOLUTE MAXIMUM RATINGS^(NOTE1)

| PARAMETERS | | Range | Unit |
|--|-----|--------------------------------|------|
| IN, LED1, LED2, LED3 | | -0.3 to 6 | V |
| SCL, SDA, STROBE | | -0.3 to (V _{IN} +0.3) | V |
| Continuous power dissipation | | Internally limited | |
| Max Junction Temperature T _{JMAX} | | 155 | °C |
| Storage Temperature T _{STG} | | -65 to 150 | °C |
| Maximum lead temperature (soldering) | | 260 | °C |
| Junction to Ambient Thermal Resistance θ_{JA} | | 92 | °C/W |
| ESD, All Pins ^(NOTE2) | HBM | ±2000 | V |
| | MM | ±200 | V |
| | CDM | ±2000 | V |
| Latch-Up JEESD78D | | +IT: +350 -IT: -350 | mA |

RECOMMENDED OPERATING CONDITIONS

| PARAMETERS | Range | Unit |
|--|------------|------|
| V _{IN} | 2.7 to 5.5 | V |
| Junction temperature (T _J) | -40 to 125 | °C |
| Ambient temperature (T _A) | -40 to 85 | °C |

NOTE1: Conditions out of those ranges listed in "absolute maximum ratings" may cause permanent damages to the device. In spite of the limits above, functional operation conditions of the device should within the ranges listed in "recommended operating conditions". Exposure to absolute-maximum-rated conditions for prolonged periods may affect device reliability.

NOTE2: The human body model is a 100pF capacitor discharged through a 1.5k Ω resistor into each pin. Test method: MIL-STD-883J Method 3015.9

ELECTRICAL CHARACTERISTICS

Typical limits tested at $T_A=25^{\circ}\text{C}$. Minimum and maximum limits apply over the full operating ambient temperature range ($-40^{\circ}\text{C}\leq T_A\leq 85^{\circ}\text{C}$). Unless otherwise specified, $V_{IN}=3.8\text{V}$.

| Symbol | Description | Test Condition | Min | Typ | Max | Unit |
|--|--|--|------|-------|----------|--------------------|
| Vin Supply | | | | | | |
| V_{IN} | Input Operating Range | | 2.7 | | 5.5 | V |
| I_{SB} | Standby Supply Current | $2.7\text{V}\leq V_{IN}\leq 5.5\text{V}$, $SCL=SDA=0\text{V}$ | | 1 | 2 | μA |
| I_Q | Quiescent Supply Current | | | 0.2 | 0.5 | mA |
| UVLO | Under Voltage Lockout Threshold | Falling V_{IN} | | 2.5 | | V |
| | | Rising V_{IN} | | 2.6 | | V |
| Current Source Specifications | | | | | | |
| $I_{LED1/2}$ | Current Source Accuracy | Flash Code=0xFF=1.0A | -10% | 1 | 10% | A |
| | | Torch Code=0x7F=187.5mA | -10% | 187.5 | 10% | mA |
| I_{LED3} | Current Source Accuracy | Flash Code =0xFF=375mA | -10% | 375 | 10% | mA |
| | | Torch Code=0x7F=187.5mA | -10% | 187.5 | 10% | mA |
| $V_{HR_LED1/2}$ | Headroom Voltage of LED1/2 | Flash Code=0xFF=1.0A | | 200 | 300 | mV |
| | | Torch Code=0x7F=187.5mA | | 50 | 75 | mV |
| V_{HR_LED3} | Headroom Voltage of LED3 | Flash Code =0xFF=375mA | | 180 | 270 | mV |
| | | Torch Code=0x7F=187.5mA | | 90 | 135 | mV |
| T_{FLASH} | Flash Time-out Duration | Reg 0x0A, bits[3:0]="1010" | -5% | 600 | 5% | ms |
| V_{IVFM} | Input Voltage Flash Monitor Trip Threshold | Reg 0x02, bits[3:1]="000" | -3% | 2.9 | 3% | V |
| T_{SD} | Thermal Shutdown Threshold | | | 155 | | $^{\circ}\text{C}$ |
| | Thermal Shutdown Hysteresis | | | 20 | | |
| I²C-Compatible Interface Specifications(SCL,SDA) | | | | | | |
| V_{IL} | Input Logic Low | | 0 | | 0.4 | V |
| V_{IH} | Input Logic High | | 1.2 | | V_{IN} | V |
| V_{OL} | Output Logic Low | $I_{LOAD}=3\text{mA}$ | | | 0.4 | V |
| STROBE Voltage Specifications | | | | | | |
| V_{IL} | Input Logic Low | | 0 | | 0.4 | V |
| V_{IH} | Input Logic High | | 1.2 | | V_{IN} | V |
| R_{PD} | Internal Pull Down Resistors | | | 300 | | k Ω |

I²C INTERFACE TIMING

| Symbol | Description | Min | Typ | Max | Units |
|-----------------------|---|-----|-----|-----|-------|
| F _{SCL} | Interface Clock Frequency | | | 400 | kHz |
| T _{DEGLITCH} | Deglitch Time | SCL | 200 | | ns |
| | | SDA | 250 | | ns |
| T _{HD:STA} | (Repeat-Start) Start Condition Hold Time | 0.6 | | | μs |
| T _{LOW} | Low Level Width of SCL | 1.3 | | | μs |
| T _{HIGH} | High Level Width of SCL | 0.6 | | | μs |
| T _{SU:STA} | (Repeat-Start) Start Condition Setup Time | 0.6 | | | μs |
| T _{HD:DAT} | Data Hold Time | 0 | | | μs |
| T _{SU:DAT} | Data Setup Time | 0.1 | | | μs |
| T _R | Rising Time of SDA And SCL | | | 0.3 | μs |
| T _F | Falling Time of SDA And SCL | | | 0.3 | μs |
| T _{SU:STO} | Stop Condition Setup Time | 0.6 | | | μs |
| T _{BUF} | Time Between Start and Stop Condition | 1.3 | | | μs |

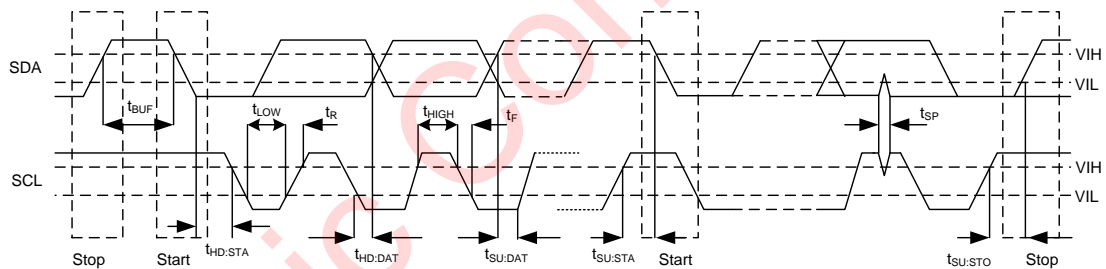
Fig 4 I²C INTERFACE TIMING

TYPICAL CHARACTERISTICS

$T_a=25^{\circ}\text{C}$, $V_{IN}=3.8\text{V}$, $V_{LED}=2.9\text{V}$ @ 375mA, IVFM=Off, unless otherwise noted .

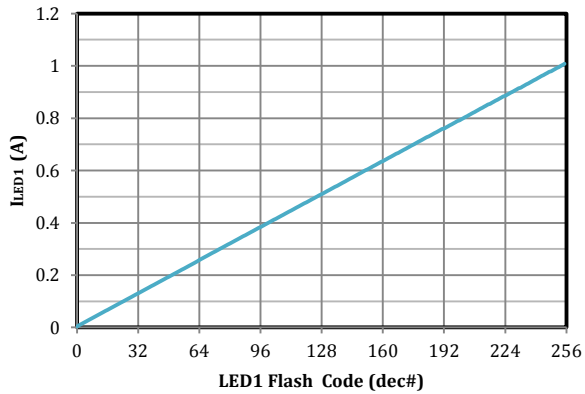

Fig 5. LED1 Flash Current vs Brightness Code

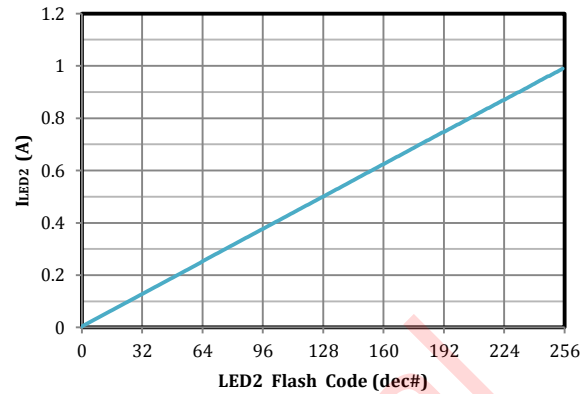

Fig 6. LED2 Flash Current vs Brightness Code

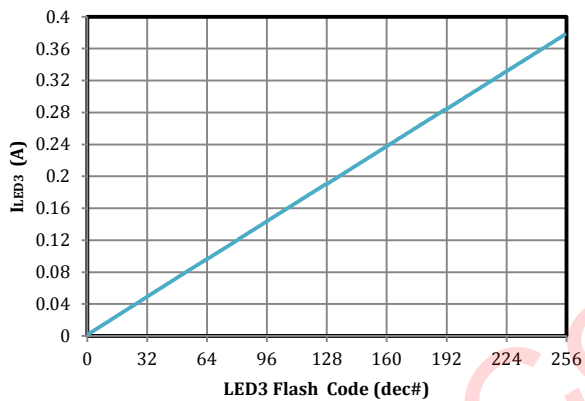

Fig 7. LED3 Flash Current vs Brightness Code

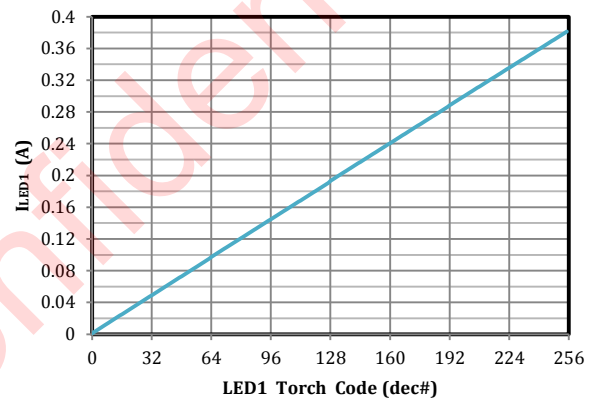

Fig 8. LED1 Torch Current vs Brightness Code

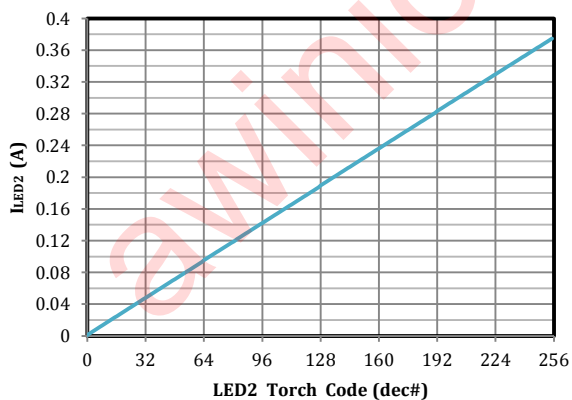

Fig 9. LED2 Torch Current vs Brightness Code

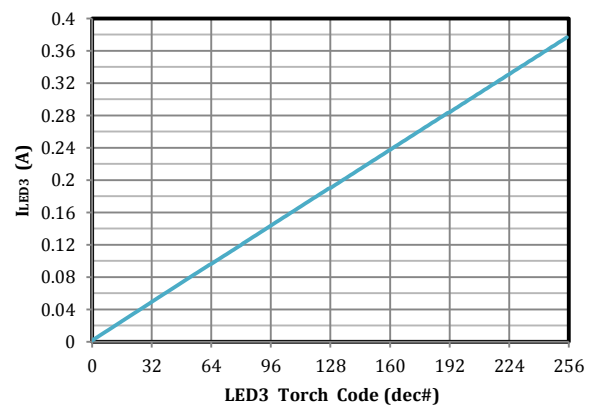

Fig 10. LED3 Torch Current vs Brightness Code

Typical Characteristics (continued)

Ta=25°C, V_{IN}=3.8V, V_{LED}=2.9V @ 375mA, IVFM=Off, unless otherwise noted .

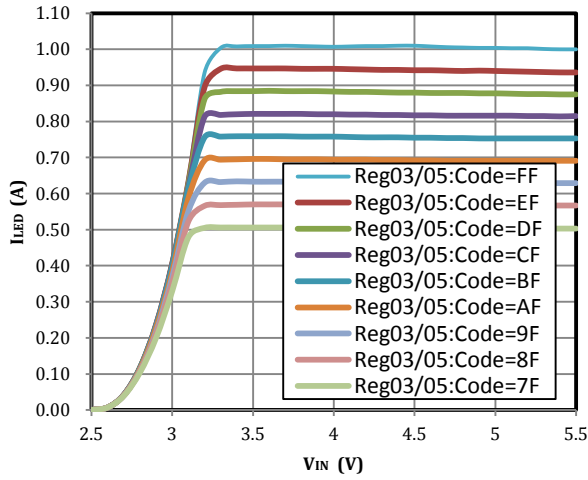

Fig 11. LED1/2 Flash Current vs Input Voltage

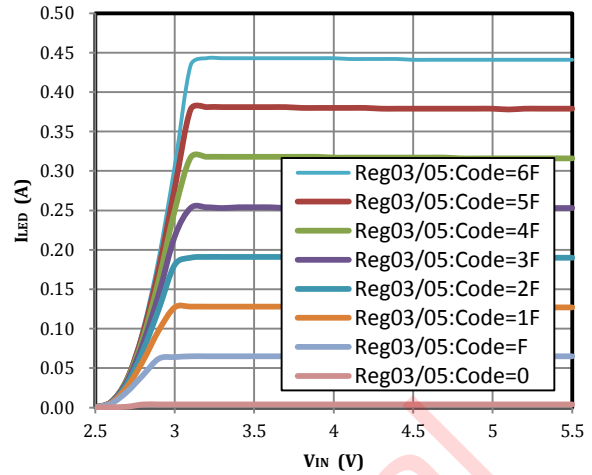

Fig 12. LED1/2 Flash Current vs Input Voltage

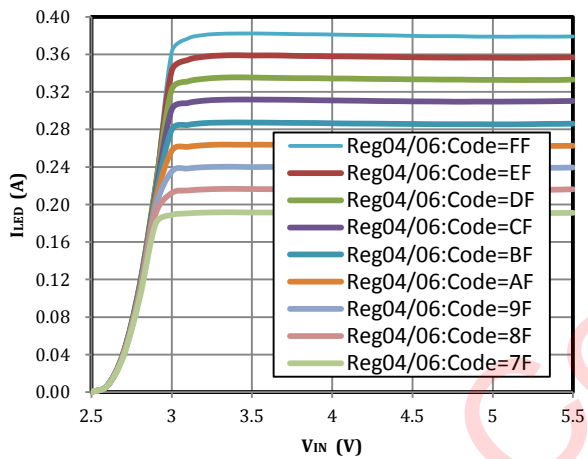

Fig 13. LED1/2 Torch Current vs Input Voltage

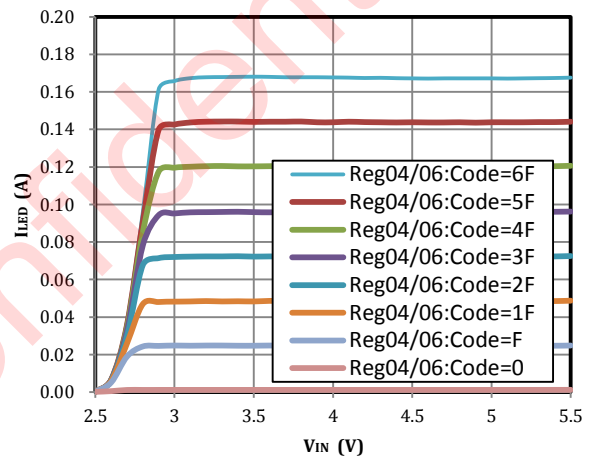

Fig 14. LED1/2 Torch Current vs Input Voltage

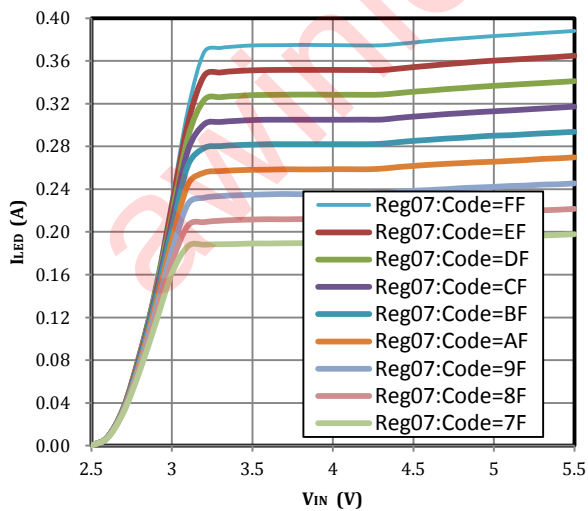

Fig 15. LED3 Flash Current vs Input Voltage

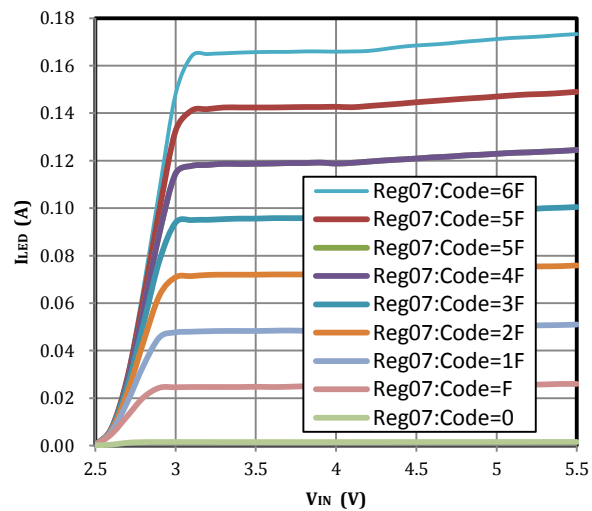

Fig 16. LED3 Flash Current vs Input Voltage

Typical Characteristics (continued)

Ta=25°C, V_{IN}=3.8V, V_{LED}=2.9V @ 375mA, IVFM=Off, unless otherwise noted .

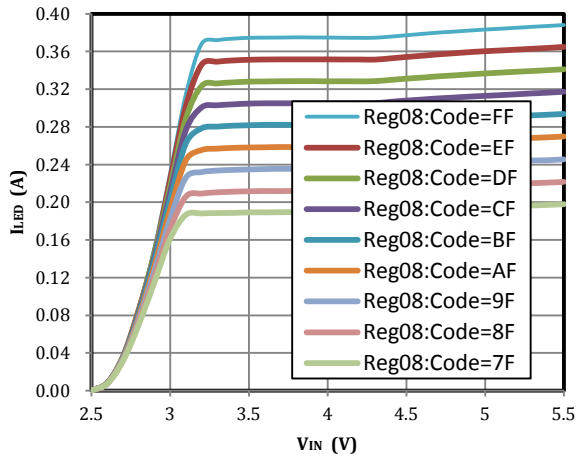

Fig 17. LED3 Torch Current vs Input Voltage

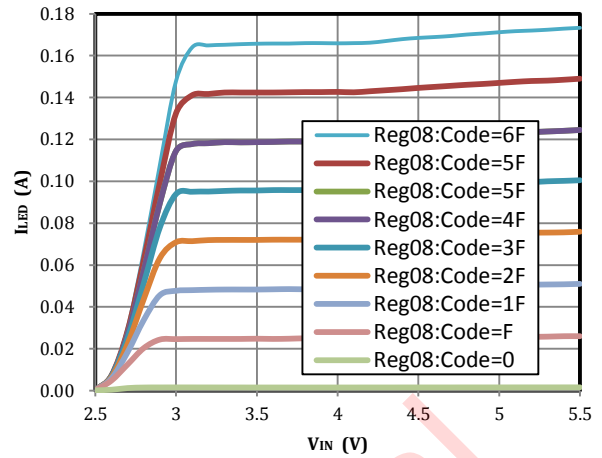

Fig 18. LED Torch Current vs Input Voltage

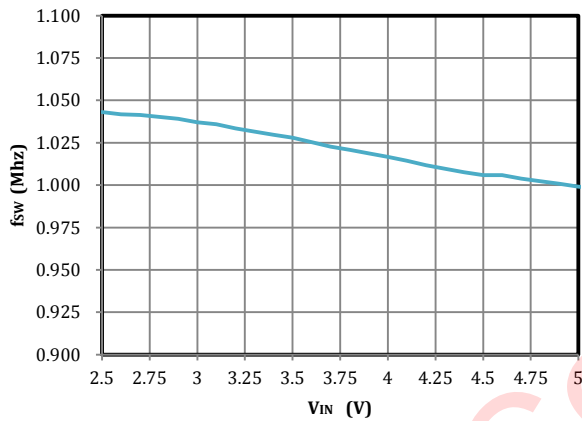

Fig 19. Oscillator Frequency vs Input Voltage

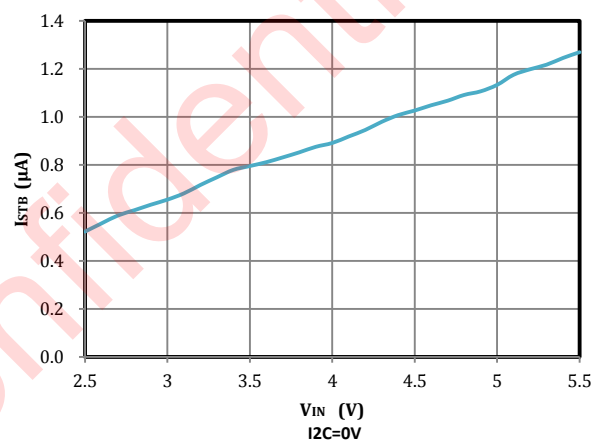

Fig 20. Standby Current vs Input Voltage

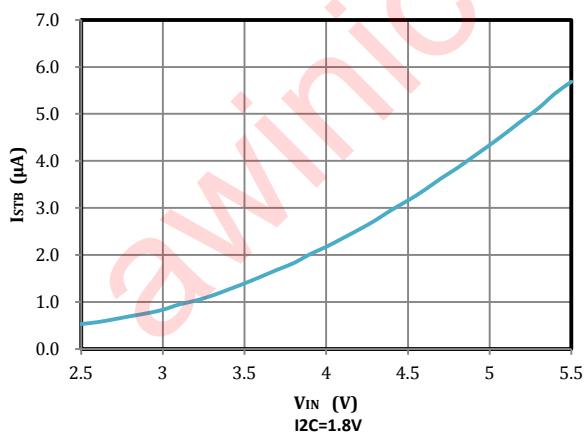

Fig 21. Standby Current vs Input Voltage

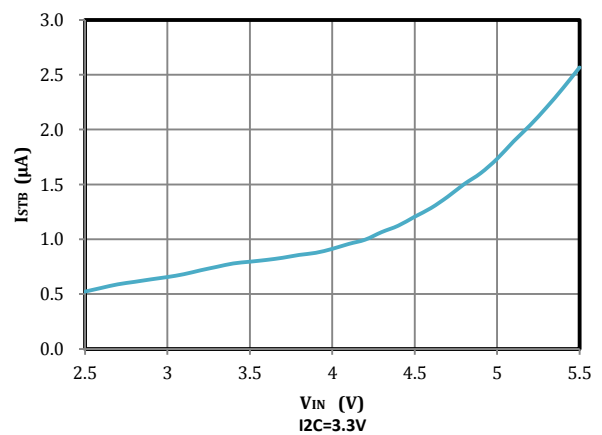
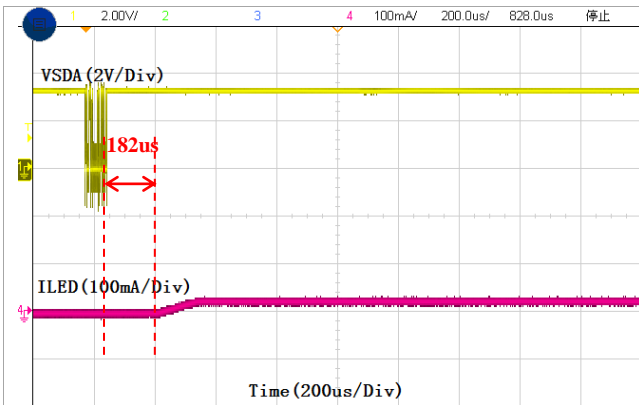

Fig 22. Standby Current vs Input Voltage

Typical Characteristics (continued)

Ta=25°C, VIN=3.8V, VLED=2.9V @ 375mA, IVFM=Off, unless otherwise noted .



ILED=187.5mA, VIN=3.5V, IVFM=3.6V

Fig 23. IVFM ON

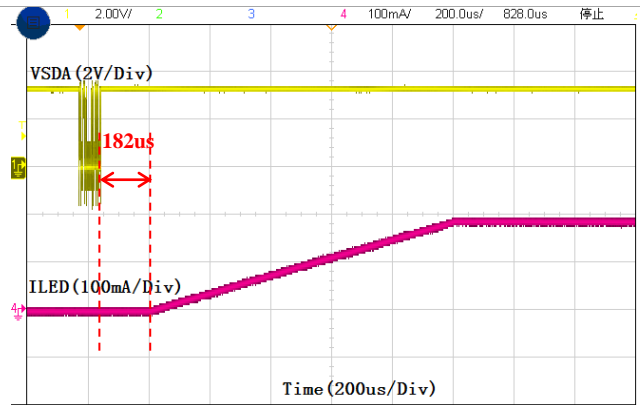

ILED=187.5mA, VIN=3.5V, IVFM=3.6V

Fig 24. IVFM OFF

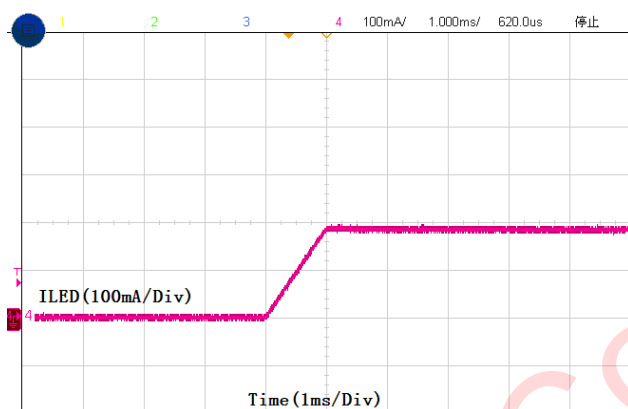

ILED=187.5mA

Fig 25. Flash Ramp up time

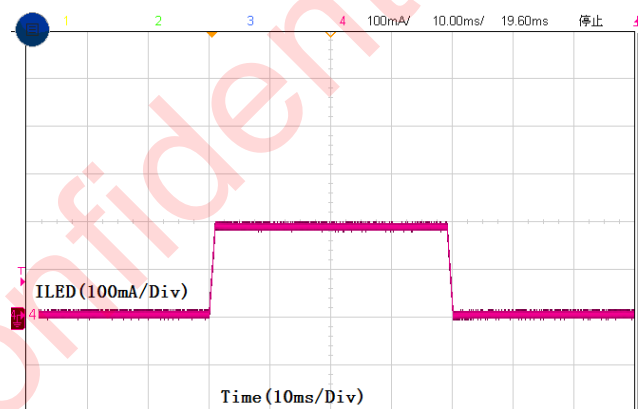

ILED=187.5mA Timeout=40ms(Reg0B(3:0)=0000)

Fig 26. Flash time out

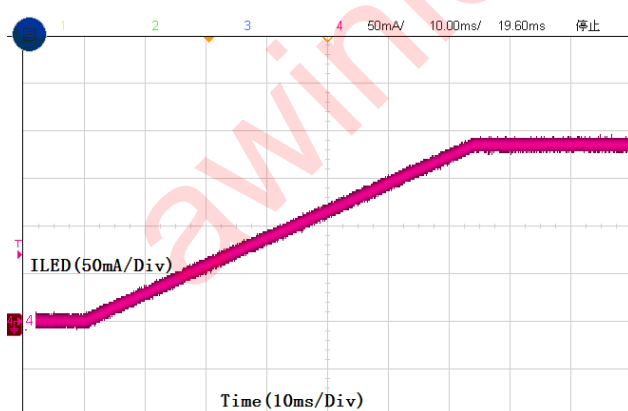

ILED=187.5mA Torch Ramp up=64ms(Reg0B(7:4)=0011)

Fig 27. Torch Ramp up time

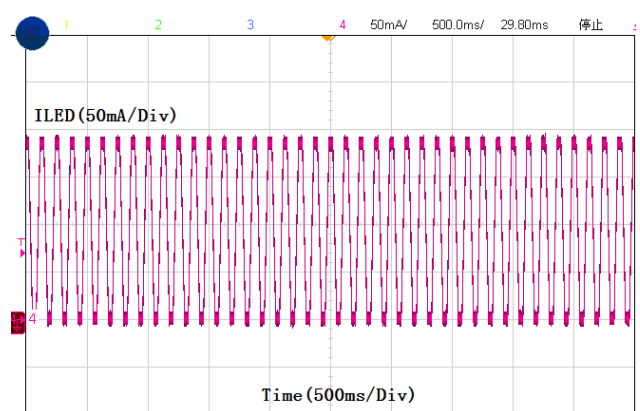

ILED=187.5mA Continuous breathing(Reg0E(7:4)=0000)

Indicator: RU=32ms, On= 64ms, RD=32ms, OFF=64ms.

Fig 28. Indicator unstop mode

Typical Characteristics (continued)

$T_a=25^{\circ}\text{C}$, $V_{IN}=3.8\text{V}$, $V_{LED}=2.9\text{V}$ @ 375mA, IVFM=Off, unless otherwise noted .

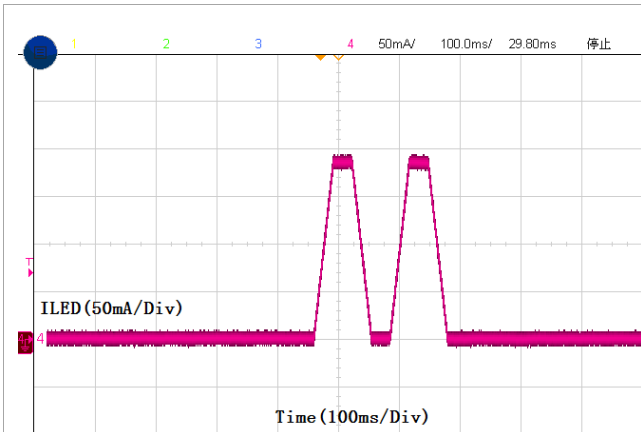

ILED=187.5mA breath twice(Reg0E(7:4)=0010)

Indicator: RU=32ms, On= 64ms, RD=32ms, OFF=64ms.

Fig 29. Indicator 2 times

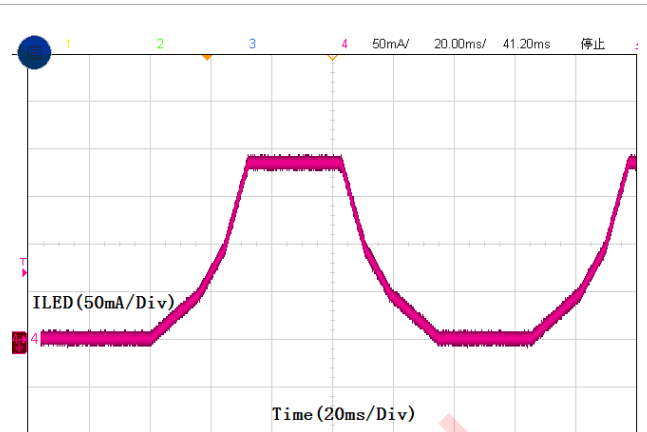

ILED=187.5mA log mode

Indicator: RU=32ms, On= 64ms, RD=32ms, OFF=64ms.

Fig 30. Indicator log mode

DETAILED FUNCTIONAL DESCRIPTION

The AW36526 is a high-power Triple-channel LED flash driver capable of delivering up to 1.0A in either of the two source LEDs and up to 0.375A in the sink LED over the 2.7V to 5.5V input voltage range.

The device has one logic input for a hardware flash enable(STROBE). This logic input has an internal 300k Ω (typical) pull-down resistor to GND.

The device is controlled via an I²C-compatible interface which includes adjustment of the Flash and Torch current levels, changing the Flash Timeout Duration, IVFM level and breath features. Additionally, there are flag and status bits that indicate flash current timeout, LED over-temperature condition, LED failure (short), device thermal shutdown, and V_{IN} under-voltage conditions.

Additional features of the device include an automatically forced LED1/2 and LED3 enable mutually exclusive to avoid the OTP occurred when all three LEDs are ON. The function can be set by bit7 in the IVFM Register(0x02).

FUNCTION BLOCK DIAGRAM

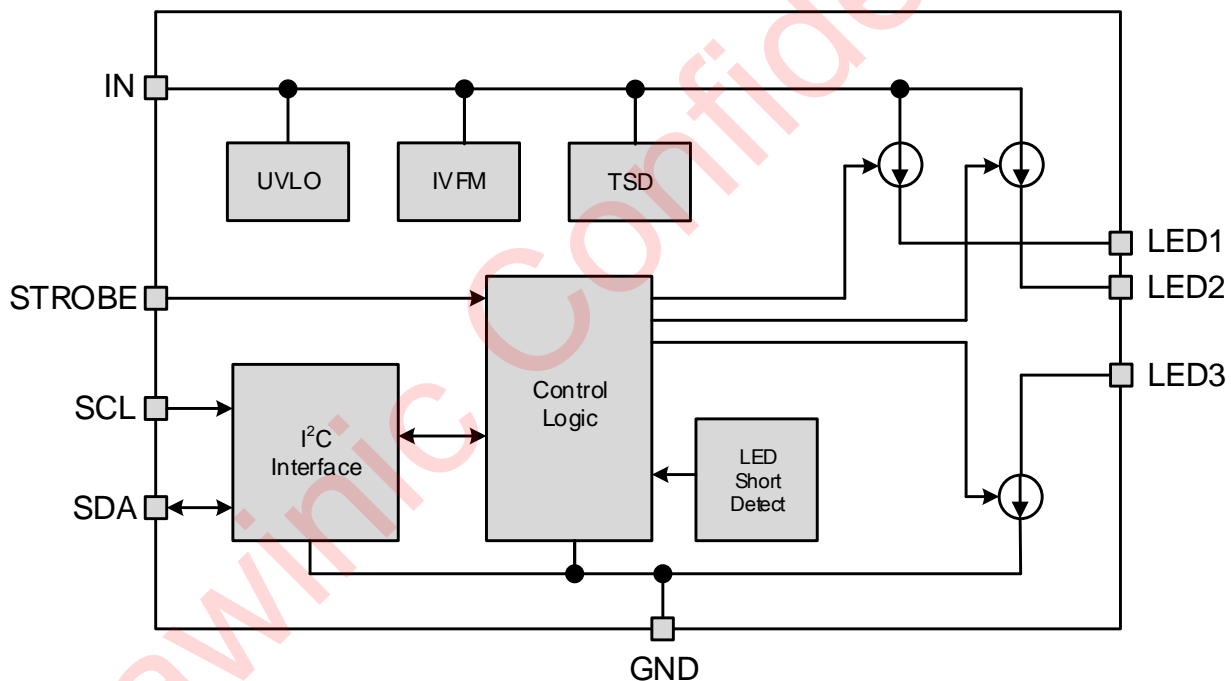

FEATURE DESCRIPTION

FLASH MODE

In Flash Mode, the LED current sources (LED1/2) provide 256 target current levels from 3.9mA to 1.0A and the LED current sink(LED3) provide 256 target current levels from 1.46mA to 375mA. The Flash currents are adjusted via the LED1,LED2 and LED3 Flash Brightness Registers. Flash mode is activated by the Enable Register(setting M1, M0 to '11'), or by pulling the STROBE pin HIGH when the pin is enabled (Enable Register). Once the Flash sequence is activated, the current sources (LED1/2) and the current sink (LED3) ramp up to the programmed Flash current by stepping through all current steps until the programmed current is reached.

When the device is enabled in Flash Mode through the Enable Register, all mode bits in the Enable Register are cleared after a flash timeout event.

TORCH MODE

In Torch mode, the LED current sources (LED1/2) provide 256 target current levels from 1.46mA to 375mA and the LED current sink(LED3) provide 256 target current levels from 1.46mA to 375mA. The Torch currents are adjusted via the LED1,LED2 and LED3 Torch Brightness Registers. Torch mode is activated by the Enable Register (setting M1, M0 to '10'). Once the TORCH sequence is activated, the active current sources (LED1/2) and the current sink (LED3) ramp up to the programmed Torch current by stepping through all current steps until the programmed current is reached. The rate at which the current ramps is determined by the value chosen in the Flash & Torch Timing Register (0x0B 7:4). Torch Mode is not affected by Flash Timeout.

IR MODE

In IR Mode, the target LED current is equal to the value stored in the LED1/2/3 Flash Brightness Registers. When IR mode is enabled (setting M1, M0 to '01'), toggling the STROBE pin enables and disables the LED1/2 current sources and LED3 current sink (if enabled). The strobe pin can only be set to be Level sensitive, meaning all timing of the IR pulse is externally controlled. In IR Mode, the current sources do not ramp the LED outputs to the target. The current transitions immediately from off to on and then on to off.

SOFTWARE RESET

Writing 0x55 to Chip ID Register (register: 0x00) via I²C interface will reset the device, including all internal circuits and configuration registers. After the software reset command is input through I²C, it needs to wait at least 2ms before any other I²C command can be accepted.

INPUT VOLTAGE FLASH MONITOR (IVFM)

The AW36526 has the ability to adjust the flash current based upon the voltage level present at the IN pin utilizing the Input Voltage Flash Monitor (IVFM). The adjustable threshold ranges from 2.9 V to 3.6 V in 100mV steps, with hold mode. The IVFM threshold are controlled by bits[3:0] in the IVFM Register(0x02). The Flags Register has the IVFM flag bit set when the input voltage crosses the IVFM threshold value and after 4us deglitch delay. Additionally, the IVFM threshold sets the input voltage boundary that forces the AW36526 to either stop ramping the flash current after 32 steps ramp up during the startup.

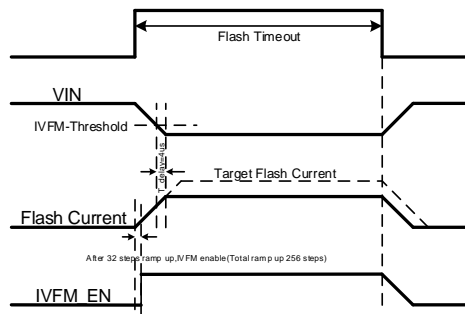

Fig 31 IVFM Timing

FLASH TIMEOUT

The Flash Timeout period sets the maximum time of one flash event, whether a flash stop command is received or not. The AW36526 has 16 timeout levels ranging from 40ms to 1.6s (see Flash & Torch TIMING CONFIGURATION REGISTER (0X0B) for more detail). Flash Timeout applies to both Flash and IR modes. The mode bits are cleared and bit[0] is set in the Flags register (0x0F) upon a Flash Timeout. This fault flag can be reset to '0' by reading back the Flags Register (0x0F), or by removing power to the AW36526.

UNDERVOLTAGE LOCKOUT (UVLO)

The AW36526 has an internal comparator that monitors the voltage at IN and forces the AW36526 into standby when the input voltage drops to 2.5 V. If the UVLO monitor threshold is tripped, the UVLO flag bit is set in the Flags Register (0x0F). If the input voltage rises above 2.5 V, the AW36526 is not available for operation until there is an I²C read of the Flags Register (0x0F). Upon a read, the Flags register is cleared, and normal operation can resume if the input voltage is greater than 2.5 V.

LED SHORT FAULT

The LED Short Fault flags read back a '1' if the device is active in Flash or Torch or IR or Indicator mode and either active LED output experiences a short condition. An LED short condition is determined if the voltage at LED1 or LED2 goes below 500mV (typ.) or the voltage between VIN and LED3 less than 520mV (typ.) while the device is in Flash or Torch or IR or Indicator mode. There is a deglitch time of 256μs before the LED Short Fault flag is valid. The mode bits are cleared upon an LED short fault. The AW36526 is not available for operation until the LED Short Fault flags is cleared. The LED Short Faults can be reset to '0' by reading back the Flags Register (0x0F), or by removing power to the AW36526.

THERMAL SHUTDOWN (TSD)

When the AW36526 die temperature reaches 155°C, the thermal shutdown detection circuit is tripped, forcing the AW36526 into standby and writing a '1' to the Thermal Shutdown Fault flag of the Flags Register (0x0F). The AW36526 is only allowed to restart after the Thermal Shutdown Fault flag is cleared. The Thermal Shutdown Faults can be reset to '0' by reading back the Flags Register (0x0F), or by removing power to the AW36526. Upon restart, if the die temperature is still above 155°C, the AW36526 resets the Fault flag and re-enters standby.

PROGRAMMING

I²C INTERFACE

Data Validation

When SCL is high level, SDA level must be constant. SDA can be changed only when SCL is low level.

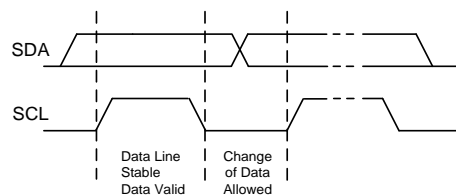

Fig 32 Data Validation Diagram

I²C Start/Stop

I²C start: SDA changes from high level to low level when SCL is high level.

I²C stop: SDA changes from low level to high level when SCL is high level.

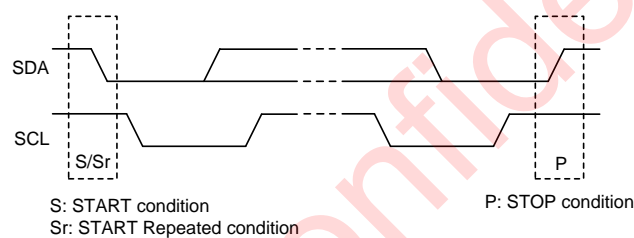

Fig 33 Start and Stop Conditions

ACK (Acknowledgement)

ACK means the successful transfer of I²C bus data. After master sends 8bits data, SDA must be released; SDA is pulled to GND by slave device when slave acknowledges.

When master reads, slave device sends 8bit data, releases the SDA and waits for ACK from master. If ACK is send and I²C stop is not send by master, slave device sends the next data. If ACK is not send by master, slave device stops to send data and waits for I²C stop.

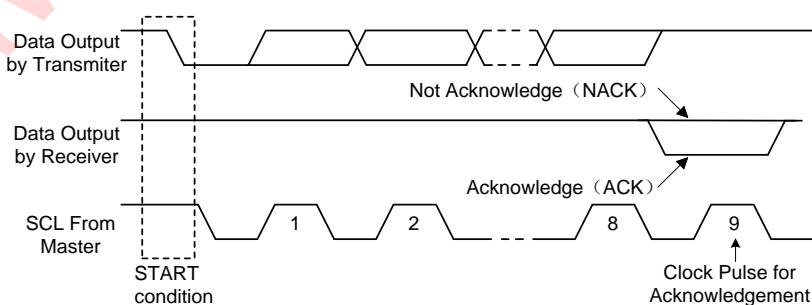

Fig 34 Acknowledgement Diagram

Write Cycle

One data bit is transferred during each clock pulse. Data is sampled during the high state of the serial clock (SCL). Consequently, throughout the clock's high period, the data should remain stable. Any changes on the SDA line during the high state of the SCL and in the middle of a transaction, aborts the current transaction. New data should be sent during the low SCL state. This protocol allows a single data line to transfer both command/control information and data using the synchronous serial clock.

Each data transaction is composed of a Start Condition, a number of byte transfers (set by the software) and a Stop Condition to terminate the transaction. Every byte written to the SDA bus must be 8 bits long and is transferred with the most significant bit first. After each byte, an Acknowledge signal must follow.

In a write process, the following steps should be followed:

- 1) Master device generates START condition. The "START" signal is generated by lowering the SDA signal while the SCL signal is high.
- 2) Master device sends slave address (7-bit) and the data direction bit (R/W = 0).
- 3) Slave device sends acknowledge signal if the slave address is correct.
- 4) Master sends control register address (8-bit)
- 5) Slave sends acknowledge signal
- 6) Master sends data byte to be written to the addressed register
- 7) Slave sends acknowledge signal
- 8) If master will send further data bytes the control register address will be incremented by one after acknowledge signal (repeat step 6, 7)
- 9) Master generates STOP condition to indicate write cycle end



Fig 35 I²C Write Timing

Read Cycle

In a read cycle, the following steps should be followed:

- 1) Master device generates START condition
- 2) Master device sends slave address (7-bit) and the data direction bit (R/W = 0).
- 3) Slave device sends acknowledge signal if the slave address is correct.
- 4) Master sends control register address (8-bit)
- 5) Slave sends acknowledge signal
- 6) Master generates STOP condition followed with START condition or REPEAT START condition
- 7) Master device sends slave address (7-bit) and the data direction bit (R/W = 1).
- 8) Slave device sends acknowledge signal if the slave address is correct.
- 9) Slave sends data byte from addressed register.
- 10) If the master device sends acknowledge signal, the slave device will increase the control register

address by one, then send the next data from the new addressed register.

11) If the master device generates STOP condition, the read cycle is ended.

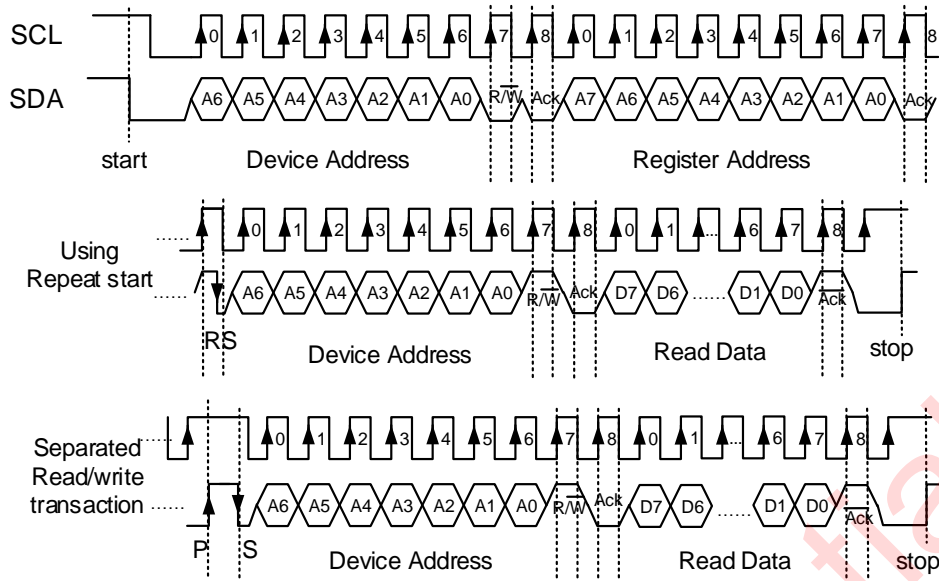

Fig 36 I²C Read Timing

REGISTER CONFIGURATION

REGISTER LIST

| Register name | Address(HEX) | Read/Write | Default Value |
|--|--------------|------------|---------------|
| Chip ID Register | 0x00 | Read | 0x17 |
| Enable Register | 0x01 | Read/Write | 0x00 |
| IVFM Register | 0x02 | Read/Write | 0xE1 |
| LED1 Flash Brightness Register | 0x03 | Read/Write | 0x7F |
| LED1 Torch Brightness Register | 0x04 | Read/Write | 0x7F |
| LED2 Flash Brightness Register | 0x05 | Read/Write | 0x7F |
| LED2 Torch Brightness Register | 0x06 | Read/Write | 0x7F |
| LED3 Flash Brightness Register | 0x07 | Read/Write | 0x7F |
| LED3 Torch Brightness Register | 0x08 | Read/Write | 0x7F |
| Flash & Torch Timing Register | 0x0B | Read/Write | 0x1A |
| Indicator Timing1 Register | 0x0C | Read/Write | 0x77 |
| Indicator Timing2 Register | 0x0D | Read/Write | 0x55 |
| Indicator Control Register | 0x0E | Read/Write | 0x00 |
| Flags Register | 0x0F | Read | 0x00 |
| Device ID Register | 0x10 | Read | 0xE6 |
| Indicator Brightness Low Bits Register | 0x11 | Read/Write | 0xFF |

REGISTER DETAILED DESCRIPTION

◇ Chip ID Register (0x00), default(0x17)

| Bit 7 | Bit 6 | Bit 5 | Bit 4 | Bit 3 | Bit 2 | Bit 1 | Bit 0 |
|----------------------------------|-------|-------|-------|-------|-------|-------|-------|
| Chip ID: "0001 0111" | | | | | | | |
| Write 55H To Reset All Registers | | | | | | | |

◇ Enable Register (0x01), default(0x00)

| Bit 7 | Bit 6 | Bit 5 | Bit 4 | Bit 3 | Bit 2 | Bit 1 | Bit 0 |
|---|---|---|-------|-------|---|---|---|
| Strobe Type 0=Level Triggered (Default) 1=Edge Triggered | Strobe Enable 0=Disabled (Default) 1=Enabled | Mode Bits: M1, M0 00=Standby (Default) 01=IR Drive 10=Torch 11=Flash | RFU | RFU | LED3 Enable 0=OFF (Default) 1=ON | LED2 Enable 0=OFF (Default) 1=ON | LED1 Enable 0=OFF (Default) 1=ON |

Note:

In Edge or Level Strobe Mode, it is recommended that the trigger pulse width be set greater than 1ms to ensure proper turn-on of the device.

◇ IVFM Register (0x02), default(0xE1)

| Bit 7 | Bit 6 | Bit 5 | Bit 4 | Bit 3 | Bit 2 | Bit 1 | Bit 0 |
|---|---|---|---|--|-------|-------|---|
| LEDX Enable Setting 0= if LED1 or LED2 is Enabled, LED3 is Disabled Internally 1=No Limitation (Default) | LED3 Pin Short Fault Detect 0=Disabled (Default) 1=Enabled | LED1/2 Pin Short Fault Detect 0=Disabled (Default) 1=Enabled | UVLO Enable 0=Disabled (Default) 1=Enabled | IVFM Levels 000=2.9 V (Default) 001=3.0 V 010=3.1 V 011=3.2 V 100=3.3 V 101=3.4 V 110=3.5 V 111=3.6 V | | | IVFM Enable 0=Disabled (Default) 1=Enabled |

◇ LED1 Flash Brightness Register (0x03), default(0x7F)

| Bit 7 | Bit 6 | Bit 5 | Bit 4 | Bit 3 | Bit 2 | Bit 1 | Bit 0 |
|--|-------|-------|-------|-------|-------|-------|-------|
| LED1 Flash Brightness Levels | | | | | | | |
| $I_{FLASH}(mA) \approx (Brightness\ Code * 3.91mA) + 3.91mA$ | | | | | | | |
| 00000000=3.91 mA | | | | | | | |
| 01111111=500 mA (Default) | | | | | | | |
| 11111111=1.0 A | | | | | | | |

◇ LED1 Torch Brightness Register (0x04), default(0x7F)

| Bit 7 | Bit 6 | Bit 5 | Bit 4 | Bit 3 | Bit 2 | Bit 1 | Bit 0 |
|--|-------|-------|-------|-------|-------|-------|-------|
| LED1 Torch Brightness Levels | | | | | | | |
| $I_{TORCH}(mA) \approx (Brightness\ Code * 1.46mA) + 1.46mA$ | | | | | | | |
| 00000000=1.46 mA | | | | | | | |
| 01111111=187.5 mA (Default) | | | | | | | |
| 11111111=375 mA | | | | | | | |

◇ LED2 Flash Brightness Register (0x05) , default(0x7F)

| Bit 7 | Bit 6 | Bit 5 | Bit 4 | Bit 3 | Bit 2 | Bit 1 | Bit 0 |
|--|-------|-------|-------|-------|-------|-------|-------|
| LED2 Flash Brightness Levels | | | | | | | |
| $I_{FLASH}(mA) \approx (Brightness\ Code * 3.91mA) + 3.91mA$ | | | | | | | |
| 00000000=3.91 mA | | | | | | | |
| 01111111=500 mA (Default) | | | | | | | |
| 11111111=1.0 A | | | | | | | |

◇ LED2 Torch Brightness Register (0x06) , default(0x7F)

| Bit 7 | Bit 6 | Bit 5 | Bit 4 | Bit 3 | Bit 2 | Bit 1 | Bit 0 |
|--|-------|-------|-------|-------|-------|-------|-------|
| LED2 Torch Brightness Levels | | | | | | | |
| $I_{TORCH}(mA) \approx (Brightness\ Code * 1.46mA) + 1.46mA$ | | | | | | | |
| 00000000=1.46 mA | | | | | | | |
| 01111111=187.5 mA (Default) | | | | | | | |
| 11111111=375 mA | | | | | | | |

◇ LED3 Flash Brightness Register (0x07) , default(0x7F)

| Bit 7 | Bit 6 | Bit 5 | Bit 4 | Bit 3 | Bit 2 | Bit 1 | Bit 0 |
|--|-------|-------|-------|-------|-------|-------|-------|
| LED3 Flash Brightness Levels | | | | | | | |
| $I_{TORCH}(mA) \approx (Brightness\ Code * 1.46mA) + 1.46mA$ | | | | | | | |
| 00000000=1.46 mA | | | | | | | |
| 01111111=187.5 mA (Default) | | | | | | | |
| 11111111=375 mA | | | | | | | |

◇ LED3 Torch Brightness Register (0x08) , default(0x7F)

| Bit 7 | Bit 6 | Bit 5 | Bit 4 | Bit 3 | Bit 2 | Bit 1 | Bit 0 |
|--|-------|-------|-------|-------|-------|-------|-------|
| LED3 Torch Brightness Levels | | | | | | | |
| $I_{TORCH}(mA) \approx (Brightness\ Code * 1.46mA) + 1.46mA$ | | | | | | | |
| 00000000=1.46 mA | | | | | | | |
| 01111111=187.5 mA (Default) | | | | | | | |
| 11111111=375 mA | | | | | | | |

◇ Flash & Torch Timing Register (0x0B) , default(0x1A)

| Bit 7 | Bit 6 | Bit 5 | Bit 4 | Bit 3 | Bit 2 | Bit 1 | Bit 0 |
|--------------------------------|-------|-------|-------|--------------------------------|-------|-------|-------|
| Torch Current Ramp time | | | | Flash Time-out Duration | | | |
| 0000=No Ramp | | | | 0000=40 ms | | | |
| 0001=1 ms (Default) | | | | 0001=80 ms | | | |
| 0010=32 ms | | | | 0010=120 ms | | | |
| 0011=64 ms | | | | 0011=160 ms | | | |
| 0100=128 ms | | | | 0100=200 ms | | | |
| 0101=256 ms | | | | 0101=240 ms | | | |
| 0110=384 ms | | | | 0110=280 ms | | | |
| 0111=512 ms | | | | 0111=320 ms | | | |
| 1000=768 ms | | | | 1000=360 ms | | | |
| 1001=1024 ms | | | | 1001=400 ms | | | |

| | |
|--|--|
| 1010=1280 ms 1011=1536 ms 1100=1792 ms 1101=2048 ms 1110=2048 ms 1111=2048 ms | 1010=600 ms (Default) 1011=800 ms 1100=1000 ms 1101=1200 ms 1110=1400 ms 1111=1600 ms |
|--|--|

◇ Indicator Timing1 Register (0x0C) , default(0x77)

| Bit 7 | Bit 6 | Bit 5 | Bit 4 | Bit 3 | Bit 2 | Bit 1 | Bit 0 |
|---|-------|-------|-------|---|-------|-------|-------|
| Indicator Ramp Up Timing Setting 0000=No Ramp 0001=1 ms 0010=32 ms 0011=64 ms 0100=128 ms 0101=256 ms 0110=384 ms 0111=512 ms (Default) 1000=768 ms 1001=1024 ms 1010=1280 ms 1011=1536 ms 1100=1792 ms 1101=2048 ms 1110=2048 ms 1111=2048 ms | | | | Indicator Ramp Down Timing Setting 0000=No Ramp 0001=1 ms 0010=32 ms 0011=64 ms 0100=128 ms 0101=256 ms 0110=384 ms 0111=512 ms (Default) 1000=768 ms 1001=1024 ms 1010=1280 ms 1011=1536 ms 1100=1792 ms 1101=2048 ms 1110=2048 ms 1111=2048 ms | | | |

◇ Indicator Timing2 Register (0x0D) , default(0x55)

| Bit 7 | Bit 6 | Bit 5 | Bit 4 | Bit 3 | Bit 2 | Bit 1 | Bit 0 |
|--|-------|-------|-------|---|-------|-------|-------|
| Indicator ON Timing Setting 0000=64 ms 0001=128 ms 0010=256 ms 0011=512 ms 0100=768 ms 0101=1024 ms (Default) 0110=1280 ms 0111=1536 ms 1000=1792 ms 1001=2048 ms 1010=2560 ms 1011=3072 ms 1100=3584 ms 1101=4096 ms 1110=4608 ms 1111=5120 ms | | | | Indicator OFF Timing Setting 0000=64 ms 0001=128 ms 0010=256 ms 0011=512 ms 0100=768 ms 0101=1024 ms (Default) 0110=1280 ms 0111=1536 ms 1000=1792 ms 1001=2048 ms 1010=2560 ms 1011=3072 ms 1100=3584 ms 1101=4096 ms 1110=4608 ms 1111=5120 ms | | | |

Note: Below is the indicator Timing sequence

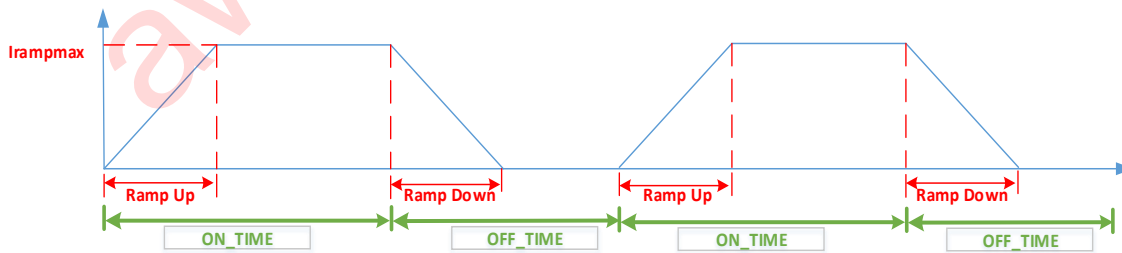

✧ Indicator Control Register (0x0E) , default(0x00)

| Bit 7 | Bit 6 | Bit 5 | Bit 4 | Bit 3 | Bit 2 | Bit 1 | Bit 0 |
|---|-------|-------|-------|--|--|-------|--|
| Breath Repeat Times 0000=Breath Continuously (Default) 0001=1 0010=2 0111=7 1111=15 | | | | Breath Ramp Type 0=Linear (Default) 1=Exponential | Indicator Status 00=Indicator Standby (Default) 01=Indicator Constant on when Breath is over 10=Chip Return to Standby when Breath is over 11= Chip Return to ON status when Breath is over | | Indicator Enable 0=Disable (Default) 1=Enable |

✧ Flags Register (0x0F) , default(0x00)

| Bit 7 | Bit 6 | Bit 5 | Bit 4 | Bit 3 | Bit 2 | Bit 1 | Bit 0 |
|---------------------|----------------|-------|------------------|------------------|------------------|------------------------------|------------|
| Flash Time-Out Flag | IVFM Trip Flag | RFU | LED3 Short Fault | LED2 Short Fault | LED1 Short Fault | Thermal Shutdown (TSD) Fault | UVLO Fault |

✧ Device ID Register (0x10) , default(0xE6)

| Bit 7 | Bit 6 | Bit 5 | Bit 4 | Bit 3 | Bit 2 | Bit 1 | Bit 0 |
|------------------------|-------|-------|-------|-------|-------|-------|-------|
| Device ID: "1110 0110" | | | | | | | |

✧ Indicator Brightness Low Bits Register (0x11) , default(0xFF)

| Bit 7 | Bit 6 | Bit 5 | Bit 4 | Bit 3 | Bit 2 | Bit 1 | Bit 0 |
|-------|-------|--|-------|---|---|-------|-------|
| RFU | RFU | LED3 Indicator Brightness Levels Low bit | RFU | LED2 Indicator Brightness Levels Low bits | LED1 Indicator Brightness Levels Low bits | | |

PCB LAYOUT

LAYOUT GUIDELINES

The PCB layout of the high-power inductorless Triple channel LED driver AW36526 is important. The following steps should be used as a reference to ensure the device is stable and maintains proper LED current regulation across its intended operating voltage and current range.

1. Place CIN on the top layer (same layer as the AW36526) and as close to the device as possible. The input capacitor conducts the driver currents during LED1/LED2/LED3 turn on and can detect current spikes over 2.8A in amplitude. Connecting the input capacitor through short, wide traces to both the IN and GND pins reduces the inductive voltage spikes that occur during switching which can corrupt the VIN line.
2. For LED1/LED2, terminate the Flash LED cathodes directly to the GND pin of the AW36526. If possible, route the LED returns with a dedicated path so as to keep the high amplitude LED currents out of the GND plane. For Flash LEDs that are routed relatively far away from the AW36526, a good approach is to sandwich the forward and return current paths over the top of each other on two layers. This helps reduce the inductance of the LED current paths.
3. For LED3, terminate the Flash LED cathodes directly to the LED3 pin of the AW36526. If possible, route the LED returns with a dedicated path so as to keep the high amplitude LED currents out of the IN plane. For Flash LEDs that are routed relatively far away from the AW36526, a good approach is to sandwich the forward and return current paths over the top of each other on two layers. This helps reduce the inductance of the LED current paths.
4. To optimize the VIN operation range, the IN and GND wire should as short and wide as possible to reduce the series resistor. Meanwhile, To optimize the heat dissipation performance, the GND pins should be connected to the PCB ground plane using as many vias as possible.

PACKAGE DESCRIPTION

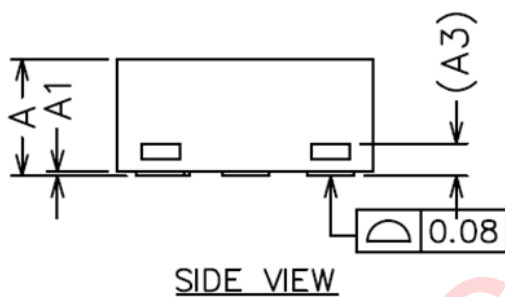
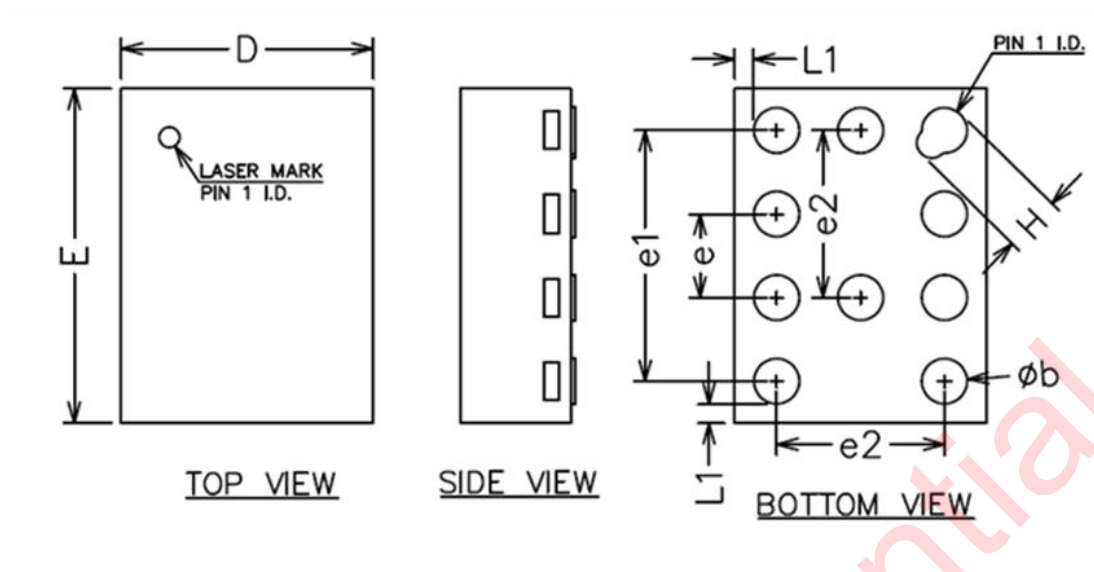
COMMON DIMENSIONS
(UNITS OF MEASURE=MILLIMETER)

| SYMBOL | MIN | NOM | MAX |
|--------|---------|------|------|
| A | 0.50 | 0.55 | 0.60 |
| A1 | 0.00 | 0.02 | 0.05 |
| A3 | 0.15REF | | |
| b | 0.17 | 0.22 | 0.27 |
| D | 1.10 | 1.20 | 1.30 |
| E | 1.50 | 1.60 | 1.70 |
| e | 0.40REF | | |
| e1 | 1.20REF | | |
| e2 | 0.80REF | | |
| H | 0.27REF | | |
| L1 | 0.09REF | | |

LAND PATTERN

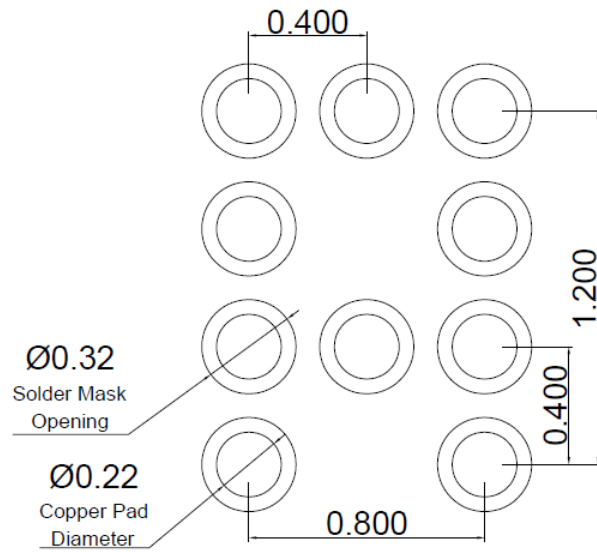

Dimensions are all in millimeters

awinic Confidential

TAPE AND REEL INFORMATION

Carrier Tape

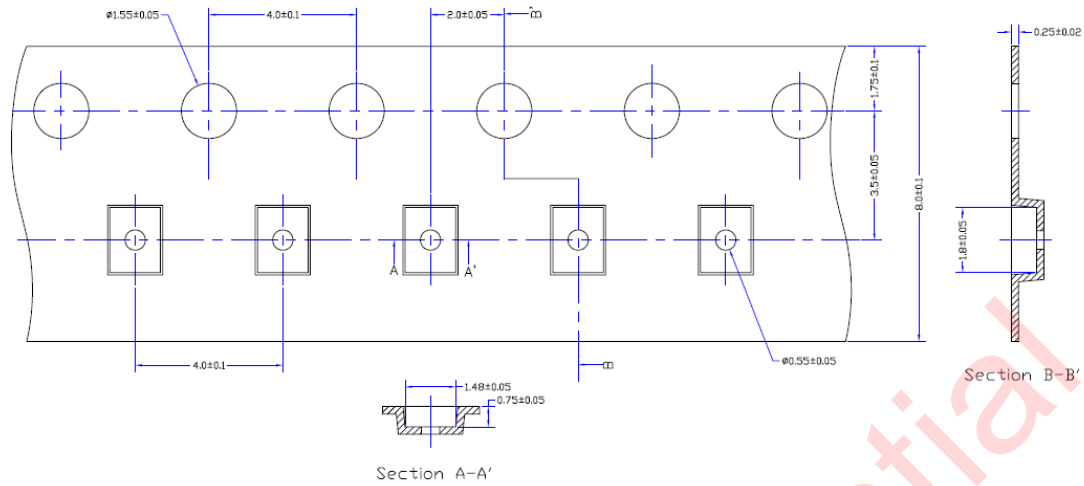

- NOTES:
 1.10 procket hole pitch cumulative tolerance ± 0.2
 2.The meander of the tape is assumed with 1mm or less every 100mm between 250mm
 3.MATERIAL:CONDUCTIVE POYSTYRENE
 4.ALL DIMS IN MM

Pin 1 direction

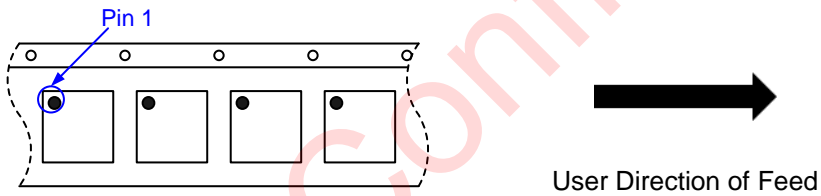

REEL

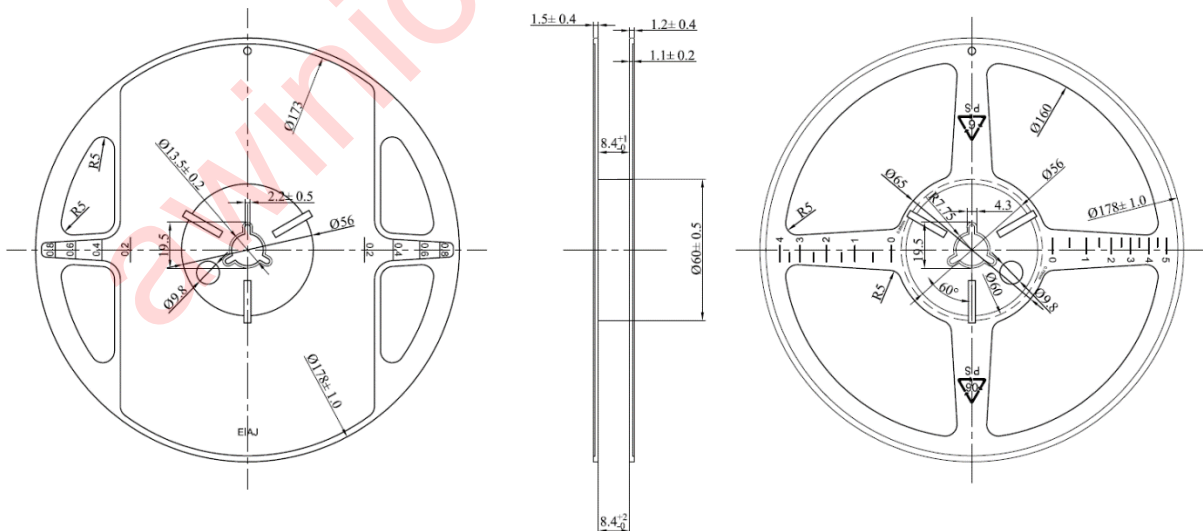

Unit: mm

REFLOW PROFILE

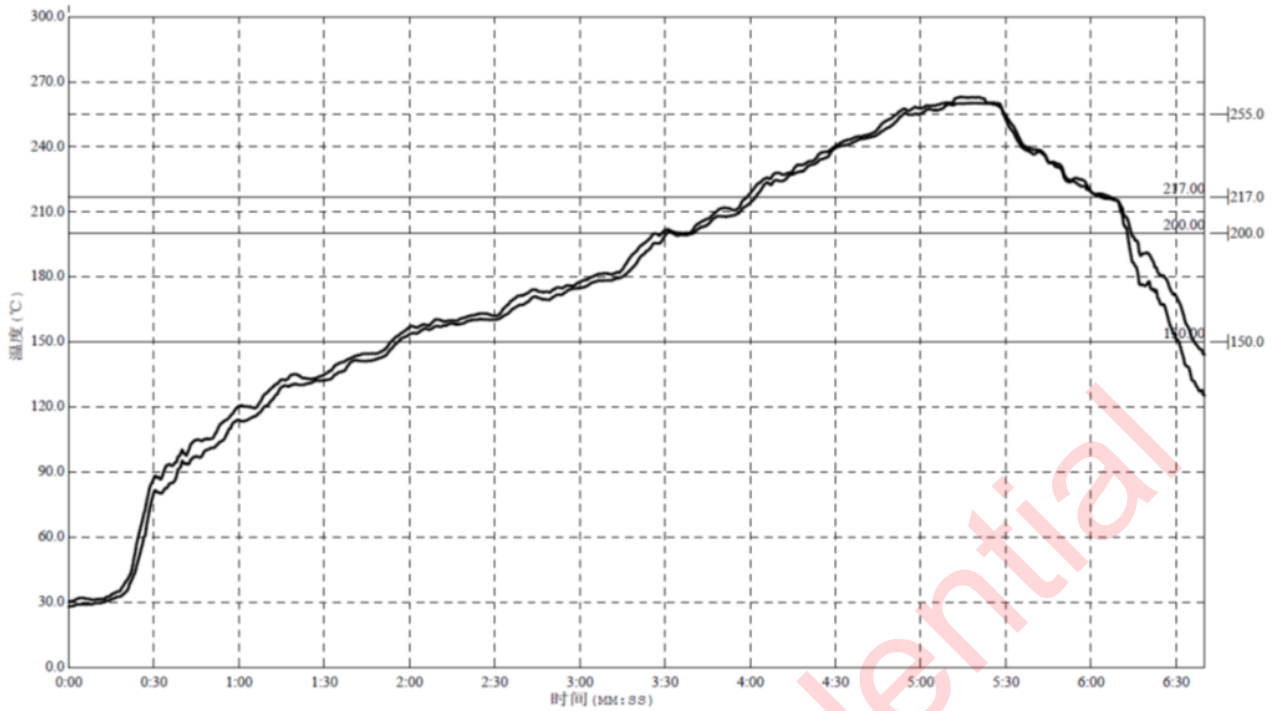

| Reflow Note | Spec |
|---|---------------|
| Average ramp-up rate (217°C to peak) | Max. 3°C /sec |
| Time of Preheat temp. (from 150°C to 200°C) | 60-120sec |
| Time to be maintained above 217°C | 60-150sec |
| Peak Temperature | >260°C |
| Time within 5°C of actual peak temp | 20-40sec |
| Ramp-down rate | Max. 6°C /sec |
| Time from 25°C to peak temp | Max. 8min |

REVISION HISTORY

| Version | Date | Change Record |
|---------|-----------|---|
| V1.0 | Oct 2017 | Product Datasheet V1.0 Released |
| V1.1 | Apr 2018 | Product Datasheet V1.1 Released-----add $V_{HR}(\max)$ value |
| V1.2 | Sep 2018 | Correction NC pin definition Correction Package: FCQFN-10L |
| V1.3 | July 2019 | Added the Software Reset definition |

awinic Confidential

DISCLAIMER

Information in this document is believed to be accurate and reliable. However, Shanghai AWINIC Technology Co., Ltd (AWINIC Technology) does not give any representations or warranties, expressed or implied, as to the accuracy or completeness of such information and shall have no liability for the consequences of use of such information.

AWINIC Technology reserves the right to make changes to information published in this document, including without limitation specifications and product descriptions, at any time and without notice. Customers shall obtain the latest relevant information before placing orders and shall verify that such information is current and complete. This document supersedes and replaces all information supplied prior to the publication hereof.

AWINIC Technology products are not designed, authorized or warranted to be suitable for use in medical, military, aircraft, space or life support equipment, nor in applications where failure or malfunction of an AWINIC Technology product can reasonably be expected to result in personal injury, death or severe property or environmental damage. AWINIC Technology accepts no liability for inclusion and/or use of AWINIC Technology products in such equipment or applications and therefore such inclusion and/or use is at the customer's own risk.

Applications that are described herein for any of these products are for illustrative purposes only. AWINIC Technology makes no representation or warranty that such applications will be suitable for the specified use without further testing or modification.

All products are sold subject to the general terms and conditions of commercial sale supplied at the time of order acknowledgement.

Nothing in this document may be interpreted or construed as an offer to sell products that is open for acceptance or the grant, conveyance or implication of any license under any copyrights, patents or other industrial or intellectual property rights.

Reproduction of AWINIC information in AWINIC data books or data sheets is permissible only if reproduction is without alteration and is accompanied by all associated warranties, conditions, limitations, and notices. AWINIC is not responsible or liable for such altered documentation. Information of third parties may be subject to additional restrictions.

Resale of AWINIC components or services with statements different from or beyond the parameters stated by AWINIC for that component or service voids all express and any implied warranties for the associated AWINIC component or service and is an unfair and deceptive business practice. AWINIC is not responsible or liable for any such statements.