

# 9V Adaptive Boost High Efficiency High PSRR Low Noise Large Volume 2-in-1 TLTR-AGC 5<sup>th</sup> Generation Smart K Audio Amplifier

## FEATURES

- ◆ Triple-Level Triple-Rate AGC algorithm to effectively eliminate noise, pure sound quality
- ◆ Half wave modulation
- ◆ High efficiency large drive ability Adaptive Boost
- ◆ The output voltage: 9.0V
- ◆ Overall efficiency up to 85%
- ◆ Maximum output Power: 4.75W@8Ω
- ◆ Support External VBST Application
- ◆ High PSRR: 82dB (217Hz)
- ◆ Low noise:
  - 45μV (K Speaker @18dB THD+N=0.012%)
  - 19μV (D Receiver @9dB THD+N=0.013%)
  - 11μV (D Receiver @0dB THD+N=0.015%)
- ◆ Selectable speaker-guard power level:
  - 0.5W~2W@8ohm, 100mW/step
- ◆ Speaker & receiver 2-in-1 mode application
- ◆ Battery tracking AGC selectable, for low voltage protection
- ◆ Shutdown current: 0.1μA
- ◆ Quiescent current: 6.8mA@3.6V
- ◆ Super TDD-Noise suppression
- ◆ Excellent pop-click suppression
- ◆ Excellent full bandwidth EMI suppression
- ◆ Support 1.8V logic I<sup>2</sup>C control
- ◆ FCQFN 2.0mm X 3.0mm X 0.55mm-20L package

## APPLICATIONS

Smart phone、Tablet PC

## GENERAL DESCRIPTION

AW87559 is specifically designed to improve the musical output dynamic range, enhance the overall sound quality. It is a new high efficiency, high PSRR, low noise, constant large volume, 5<sup>th</sup> generation Smart K audio amplifier. AW87559 integrates AWINIC's proprietary Triple-Level Triple-Rate AGC audio algorithm, effectively eliminating music noise and improving sound quality and volume. AW87559 integrates high voltage synchronous adaptive Boost with efficiency up to 88% as the class D power stage supply, significantly improving the dynamic range of music. AW87559 noise floor is as low as to 45μV at speaker mode, with 103dB high signal-to-noise ratio (SNR). The ultra-low distortion 0.012% and unique Triple-Level Triple-Rate AGC technology bring high quality music enjoyment.

It supports speaker and receiver 2-in-1 application. Quiescent current is 6.8mA when VDD is equal to 3.6V. In the receiver mode, its ultra-low noise is 11μV. Class D receiver also has high PSRR performance to completely suppress TDD-noise.

It controls internal registers through the I<sup>2</sup>C interface. Register parameters include boost output voltage, boost maximum input peak current, PA gain, Triple-Level Triple-Rate AGC parameters, etc. It built-in over current protection, over temperature protection and short circuit protection function, effectively protect the chip.

AW87559 features FCQFN 2.0mm X3.0mm X 0.55mm-20L package

TYPICAL APPLICATION CIRCUIT

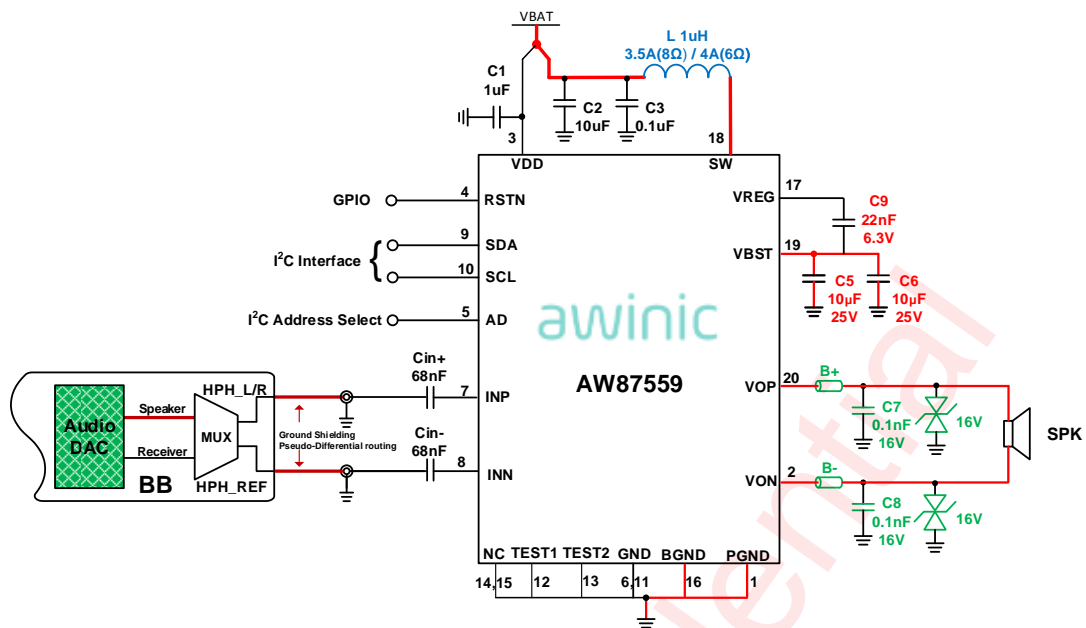

Figure 1 AW87559 Single-ended Input Mode Application Diagram

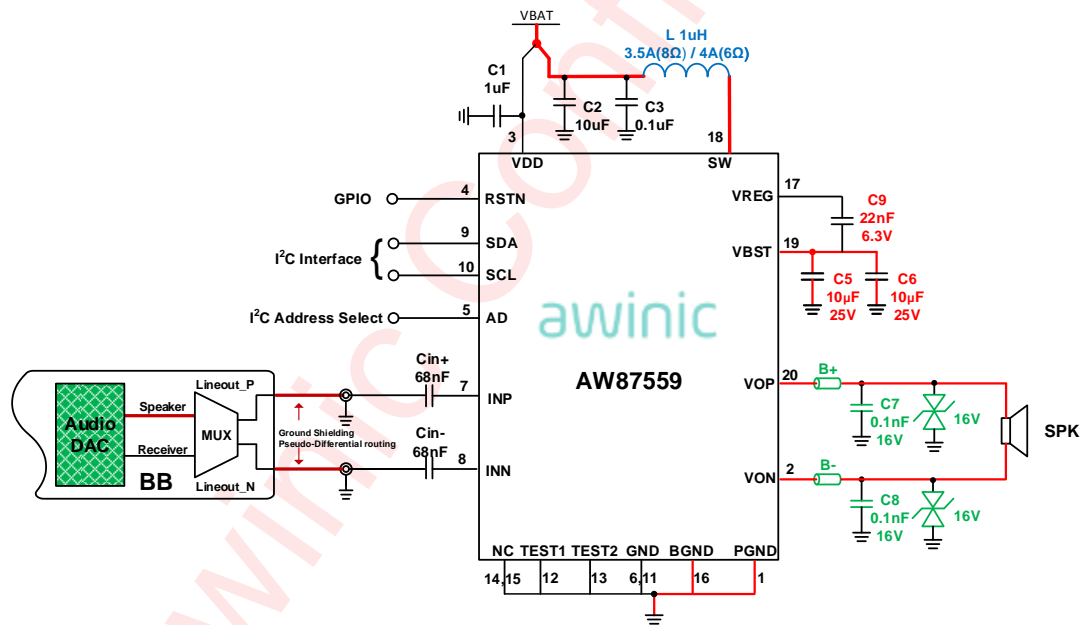

Figure 2 AW87559 Differential Input Mode Application Diagram

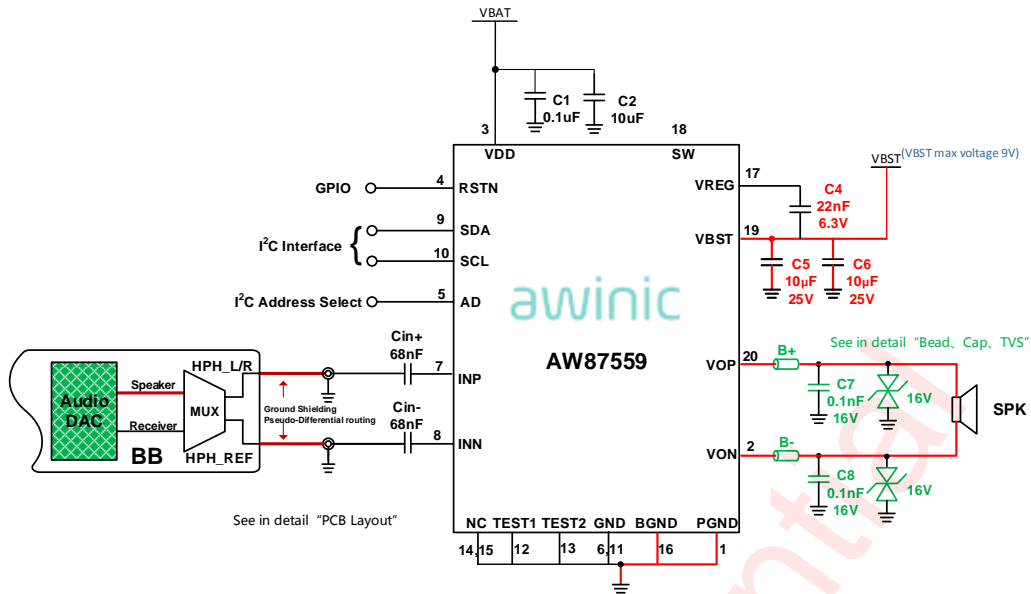

Figure 3 AW87559 External power supply VBST ( EX-VBST ) Mode Application Diagram

All trademarks are the property of their respective owners.

## PIN CONFIGURATION AND TOP MARK

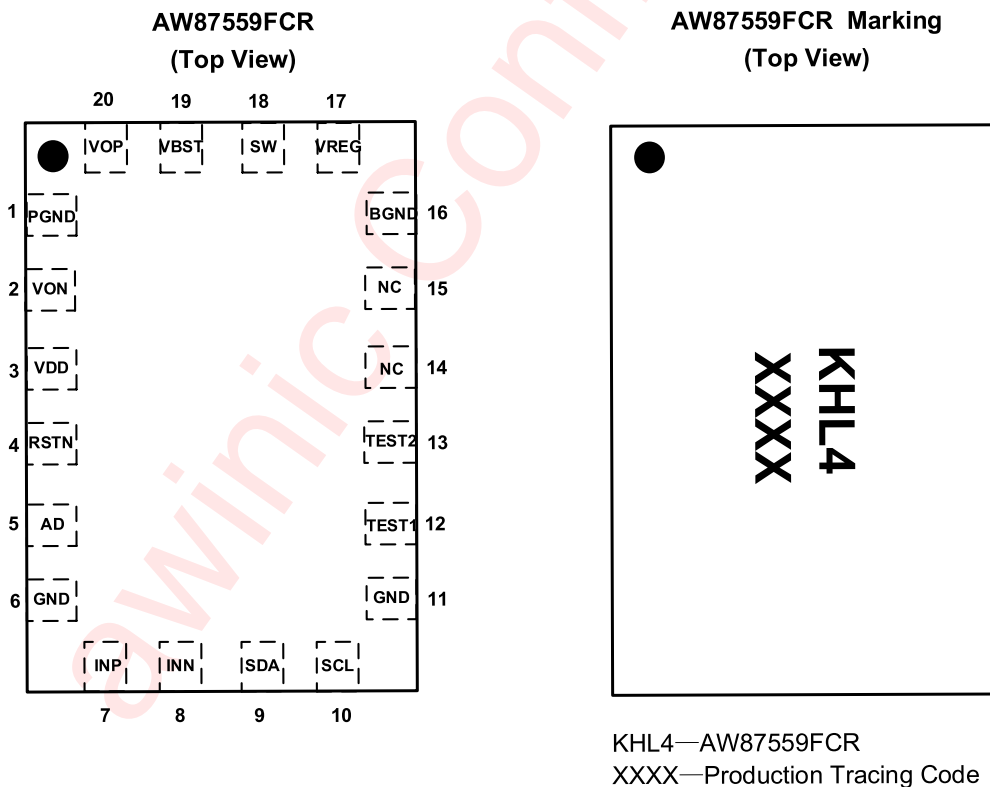

Figure 4 AW87559FCR Pin configuration and Top Mark

## PIN DESCRIPTION

Number	Symbol	Description
1	PGND	Class D power ground
2	VON	Negative audio output terminal
3	VDD	Power supply
4	RSTN	Reset pin, active low reset, the internal 2MΩ pull-down resistor in chip
5	AD	I <sup>2</sup> C address pin
6	GND	Ground
7	INP	Positive audio input terminal
8	INN	Negative audio input terminal
9	SDA	I <sup>2</sup> C-bus data input/output
10	SCL	I <sup>2</sup> C-bus clock input
11	GND	Ground
12	TEST1	Test1 pad, connect to GND in application
13	TEST2	Test2 pad, connect to GND in application
14~15	NC	Connect to GND in application
16	BGND	Boost power ground
17	VREG	Charge pump output pin
18	SW	Boost switch pin
19	VBST	Boost output pin.
20	VOP	Positive audio output terminal

## FUNCTIONAL DIAGRAM

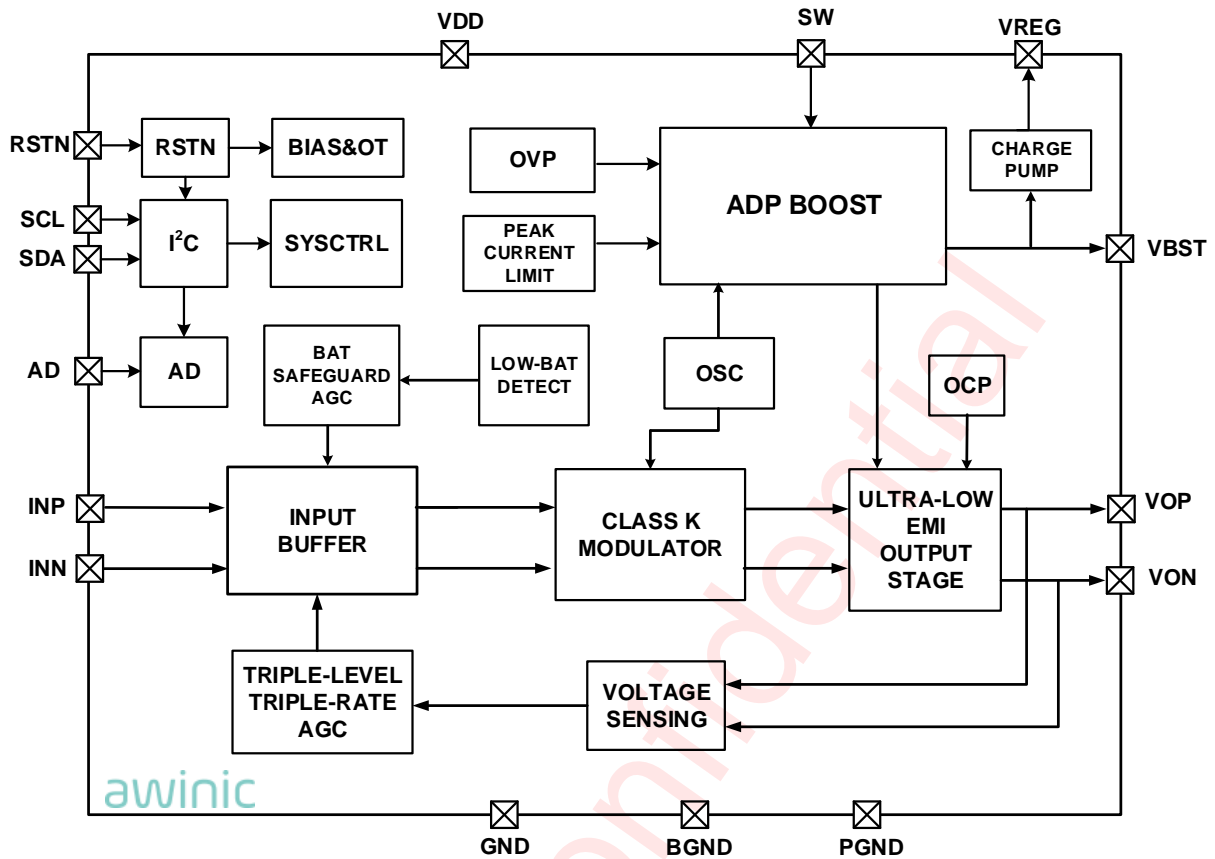

Figure 5 AW87559 Functional Diagram

## TYPICAL APPLICATION CIRCUIT

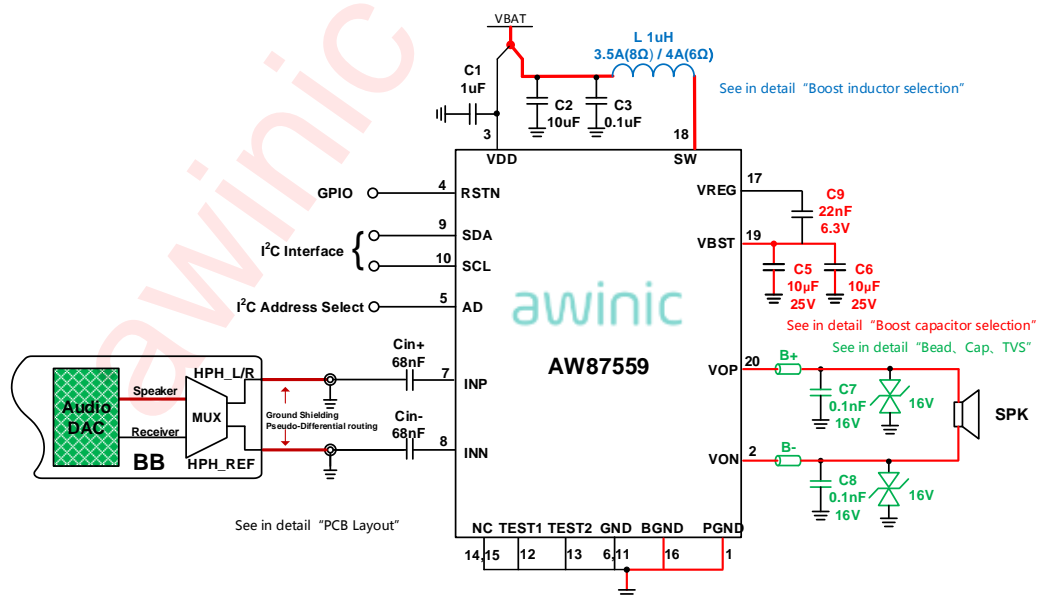

Figure 6 AW87559 Single-ended Input Mode Application Diagram (Note 1)

**Note1:** When single-ended input, audio signal line from audio DAC (HPH\_L or HPH\_R) can arbitrarily connected to either of INN or INP input terminal. The other terminal must be connected to reference ground (HPH\_REF) through input capacitor and resistor.

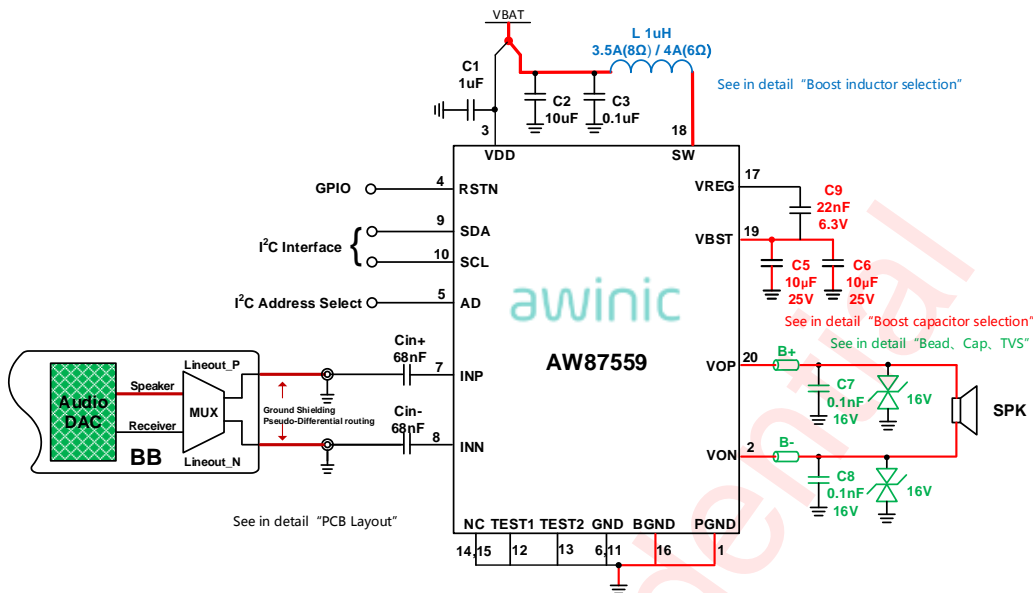

Figure 7 AW87559 Differential Input Mode Application Diagram

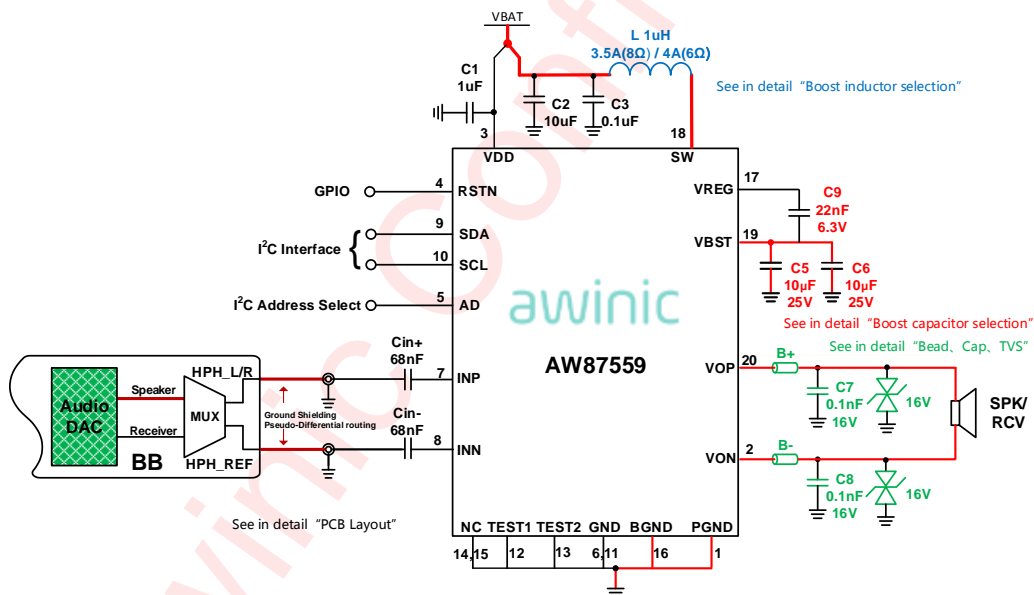

Figure 8 AW87559 Speaker & Receiver 2-in-1 Mode Application Diagram

## ORDERING INFORMATION

Part Number	Temperature	Package	Marking	Moisture Sensitivity Level	Environmental Information	Delivery Form
AW87559FCR	-40°C~85°C	FCQFN 2.0mmX3.0mm X0.55mm -20L	KHL4	MSL1	ROHS+HF	6000 units/ Tape and Reel

**ABSOLUTE MAXIMUM RATING** (Note2)

Parameter	Range
Supply Voltage VDD	-0.3V to 6V
INN,INP	-0.3V to VDD+0.3V
Boost output voltage VBST	-0.3V to 12V
SW	-0.3V to VBST+2V
VOP,VON	-0.3V to VBST+0.3V
Minimum load resistance $R_L$	3.2 $\Omega$
Package Thermal Resistance $\theta_{JA}$	57.9°C/W
Ambient Temperature Range	-40°C to 85°C
Maximum Junction Temperature $T_{JMAX}$	165°C
Storage Temperature Range $T_{STG}$	-65°C to 150°C
Lead Temperature (Soldering 10 Seconds)	260°C
ESD Rating (Note 3)	
HBM (human body model)	±2kV
CDM (charged-device model)	±1.5kV
Latch-up	
Test Condition: JEDEC STANDARD NO.78E	+IT: 450mA -IT: -450mA

**NOTE2:** Conditions out of those ranges listed in "absolute maximum ratings" may cause permanent damages to the device. In spite of the limits above, functional operation conditions of the device should within the ranges listed in "recommended operating conditions". Exposure to absolute-maximum-rated conditions for prolonged periods may affect device reliability.

**NOTE3:** The human body model is a 100pF capacitor discharged through a 1.5k $\Omega$  resistor into each pin. Test method: ESDA/JEDEC JS-001-2017

Test method of the charge device model: ESDA/JEDEC JS-002-2018

**ELECTRICAL CHARACTERISTICS**Test condition:  $T_A=25^{\circ}\text{C}$ ,  $V_{DD}=4.2\text{V}$ ,  $V_{BST}=9.0\text{V}$ ,  $R_L=8\Omega+33\mu\text{H}$ ,  $f=1\text{kHz}$  (unless otherwise noted)

Parameter		Test conditions	Min	Typ	Max	Units
VDD	Power supply voltage		2.8		5.5	V
UVLO	Under-voltage protection voltage			2.5		V
	Under-voltage protection hysteresis voltage			100		mV
V <sub>IH</sub>	RSTN, SCL, SDA, AD high-level input voltage		1.3		VDD	V
V <sub>IL</sub>	RSTN, SCL, SDA, AD low-level input voltage		0		0.45	V
I <sub>SD</sub>	Shutdown current	VDD=3.6V, RSTN=0V		0.1	1	$\mu\text{A}$
T <sub>TG</sub>	Thermal AGC start temperature threshold			150		$^{\circ}\text{C}$
T <sub>TGR</sub>	Thermal AGC exit temperature threshold			130		$^{\circ}\text{C}$
T <sub>SD</sub>	Over temperature protection threshold			160		$^{\circ}\text{C}$
T <sub>SDR</sub>	Over temperature protection recovery threshold			130		$^{\circ}\text{C}$
T <sub>ON</sub>	Turn-On time			45		ms
<b>BOOST</b>						
VBST	BOOST Output voltage	VDD=2.8V to 5.5V		9.0 (Note4)		V
OVP	OVP voltage	VDD=2.8V to 5.5V		VBST+0.5		V
	OVP hysteresis voltage	VDD=2.8V to 5.5V		500		mV
I <sub>L_PEAK</sub>	Inductor peak current limit			3.5 (Note4)		A
F <sub>BST</sub>	Boost operating frequency	VDD=2.8V to 5.5V	1.2	1.6	2	MHz
D <sub>MAX</sub>	The maximum duty cycle			90		%
T <sub>ST</sub>	Soft-start time	No load, C <sub>OUT</sub> =22 $\mu\text{F}$		2		ms
$\eta_{CP}$	Boost efficiency	VDD=4.2V, I <sub>load</sub> =200mA		88		%
<b>CLASS K MODE</b>						
V <sub>OS</sub>	Output offset voltage	No input	-30	0	30	mV
$\eta_T$	Total efficiency (ADP BOOST+CLASS D)	VDD=4.2V, P <sub>o</sub> =0.4W, R <sub>L</sub> =8 $\Omega$ +33 $\mu\text{H}$		85		%
	Total efficiency (ADP BOOST+CLASS D)	VDD=4.2V, P <sub>o</sub> =2.5W, R <sub>L</sub> =8 $\Omega$ +33 $\mu\text{H}$		82		%
I <sub>QK</sub>	Speaker Quiescent current at ADP BOOST MODE	VDD=4.2V, input ac grounded, R <sub>L</sub> =8 $\Omega$ +33 $\mu\text{H}$		6.8		mA
R <sub>dson</sub>	Drain-Source on-state resistance	High side MOS + Low side MOS		250		m $\Omega$

Parameter		Test conditions		Min	Typ	Max	Units
V <sub>inp</sub>	Recommended input signal amplitude	VDD=2.8V to 5.5V				1	V <sub>p</sub>
F <sub>osc</sub>	Modulation frequency	VDD=2.8V to 5.5V		600		1000	kHz
P <sub>agc</sub>	TLTR AGC power	R <sub>L</sub> =8Ω+33μH		0.72	0.8 (Note4)	0.88	W
		R <sub>L</sub> =6Ω+33μH		0.96	1.067 (Note4)	1.17	W
PSRR	Power supply rejection ratio	VDD=4.2V, V <sub>pp_sin</sub> =200mV	217Hz		80		dB
			1kHz		76		dB
SNR	Signal-to-noise ratio	VDD=4.2V, P <sub>o</sub> =4.75W, A <sub>v</sub> =18dB, R <sub>L</sub> =8Ω+33μH,			103		dB
		VDD=4.2V, P <sub>o</sub> =0.8W, A <sub>v</sub> =18dB, R <sub>L</sub> =8Ω+33μH,			95		dB
E <sub>N</sub>	Speaker Output noise	A <sub>v</sub> =24dB	20Hz to 20kHz, input ac grounded, A-weighting		55		μV
		A <sub>v</sub> =18dB			45		
A <sub>v</sub>	Speaker gain	VDD=2.8V to 5.5V			24 (Note4)		dB
R <sub>ini</sub>	Speaker Inner input resistance	A <sub>v</sub> =24dB			9		kΩ
	Speaker Inner input resistance	A <sub>v</sub> =18dB			18		
F <sub>in</sub>	Speaker input Cut-off frequency	C <sub>in</sub> =47nF, A <sub>v</sub> =24dB			376		Hz
	Speaker input Cut-off frequency	C <sub>in</sub> =47nF, A <sub>v</sub> =18dB			188		
	Speaker input Cut-off frequency	C <sub>in</sub> =68nF, A <sub>v</sub> =24dB			260		
	Speaker input Cut-off frequency	C <sub>in</sub> =68nF, A <sub>v</sub> =18dB			130		
	Speaker input Cut-off frequency	C <sub>in</sub> =100nF, A <sub>v</sub> =24dB			177		
	Speaker input Cut-off frequency	C <sub>in</sub> =100nF, A <sub>v</sub> =18dB			88		
THD+N	Total harmonic distortion + noise	VDD=4.2V, P <sub>o</sub> =0.8W, R <sub>L</sub> =8Ω+33μH, f=1kHz			0.012		%
P <sub>o</sub>	Speaker Output Power	THD+N=1%, R <sub>L</sub> =8Ω+33μH, VDD=4.2V, V <sub>BST</sub> =9.0V, I <sub>L_PEAK</sub> =4A			4.75		W
		THD+N=10%, R <sub>L</sub> =8Ω+33μH, VDD=4.2V, V <sub>BST</sub> =9.0V, I <sub>L_PEAK</sub> =4A			5.85		W
		THD+N=1%, R <sub>L</sub> =6Ω+33μH, VDD=4.2V, V <sub>BST</sub> =9.0V, I <sub>L_PEAK</sub> =4A			5.55		W

Parameter		Test conditions		Min	Typ	Max	Units
		THD+N=10% , $R_L=6\Omega+33\mu\text{H}$ , VDD=4.2V, VBST=9.0V, $I_{L\_PEAK}=4\text{A}$			6.75		W
<b>2-in-1 Receiver MODE</b>							
$I_{QD}$	D Receiver quiescent current (overall)	VDD=4.2V, input ac grounded, $R_L=8\Omega+33\mu\text{H}$			6.8		mA
$\eta_D$	CLASS D Receiver efficiency	VDD=4.2V, $P_o=0.8\text{W}$ , $R_L=8\Omega+33\mu\text{H}$			90		%
$A_v$	gain	VDD=2.8V to 5.5V			0 (Note4)		dB
R <sub>ini</sub>	CLASS D Receiver Inner input resistance	$A_v=9\text{dB}$			38		k $\Omega$
F <sub>in</sub>	CLASS D Receiver input cut-off frequency	$C_{in}=47\text{nF}$ , $A_v=9\text{dB}$			89		Hz
	CLASS D Receiver input cut-off frequency	$C_{in}=68\text{nF}$ , $A_v=9\text{dB}$			62		
	CLASS D Receiver input cut-off frequency	$C_{in}=100\text{nF}$ , $A_v=9\text{dB}$			42		
E <sub>N</sub>	CLASS D Receiver output noise	$A_v=0\text{dB}$	20Hz to 20kHz, input ac grounded, A-weighting		11		$\mu\text{V}$
		$A_v=9\text{dB}$			19		$\mu\text{V}$
THD+N	Total harmonic distortion + noise	VDD=4.2V, $P_o=0.1\text{W}$ , $R_L=8\Omega+33\mu\text{H}$ , $f=1\text{kHz}$ , CLASS D Receiver			0.015		%
PSRR	CLASS D Receiver Power supply rejection ratio	VDD=4.2V, $V_{p-p\_sin}=200\text{mV}$	217Hz		82		dB
			1kHz		80		dB
$P_o$	CLASS D Receiver Output Power	THD+N=1%, $R_L=8\Omega+33\mu\text{H}$ , VDD=4.2V, GAIN=7.5~10.5dB			1.0		W
<b>Battery Tracking AGC</b>							
V <sub>BSGD</sub>	Battery protection threshold voltage				3.4 (Note4)		V
V <sub>HYS</sub>	Battery protection Hysteresis voltage				100		mV
<b>Triple-Level Triple-Rate AGC</b>							
T <sub>AT1</sub>	AGC1 Attack Time				0.08 (Note4)		ms/dB
T <sub>AT2</sub>	AGC2 Attack Time				0.64 (Note4)		ms/dB
T <sub>AT3</sub>	AGC3 Attack Time				41 (Note4)		ms/dB
T <sub>RLT</sub>	Release time				21 (Note4)		ms/dB
A <sub>MAX</sub>	The maximum attenuation gain	VDD=2.8V to 5.5V			-13.5		dB

**Note 4:** Registers are adjustable; Refer to the list of registers.

awinic Confidential

## MEASUREMENT SETUP

AW87559 features switching digital output, as shown in Figure 9. Need to connect a low pass filter to VOP/VON output respectively to filter out switch modulation frequency, then measure the differential output of filter to obtain analog output signal.

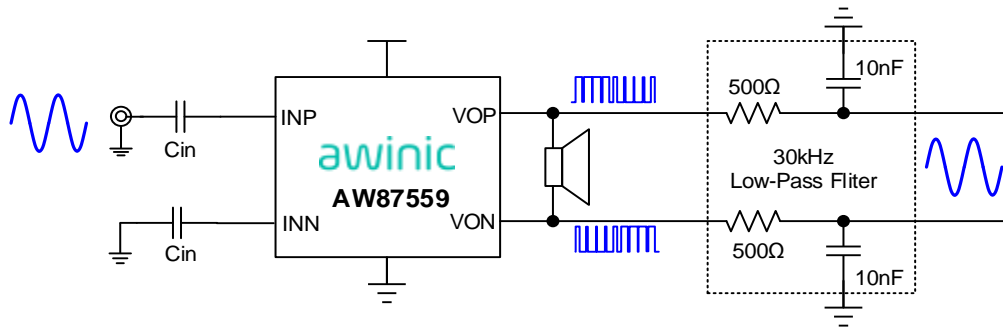

Figure 9 AW87559 Test Setup

Low pass filter uses resistance and capacitor values listed in Table 1.

R <sub>filter</sub>	C <sub>filter</sub>	Low-pass cutoff frequency
500Ω	10nF	32kHz
1kΩ	4.7nF	34kHz

Table 1 AW87559 Recommended Values for Low Pass Filter

### Output Power Calculation

According to the above test methods, the differential analog output signal is obtained at the output of the low pass filter. The valid values Vo<sub>rms</sub> of the differential signal, as shown in Figure 10:

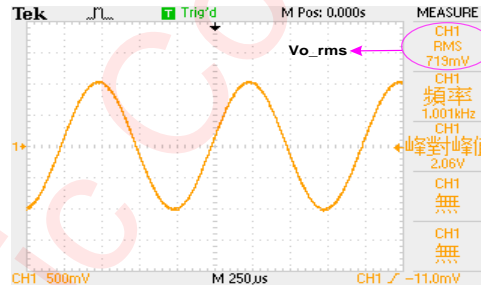
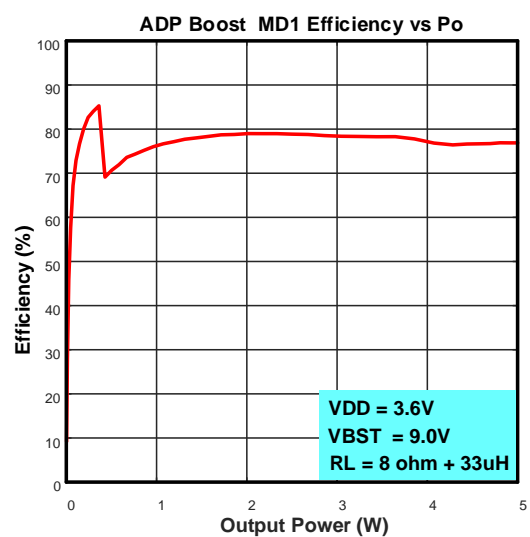
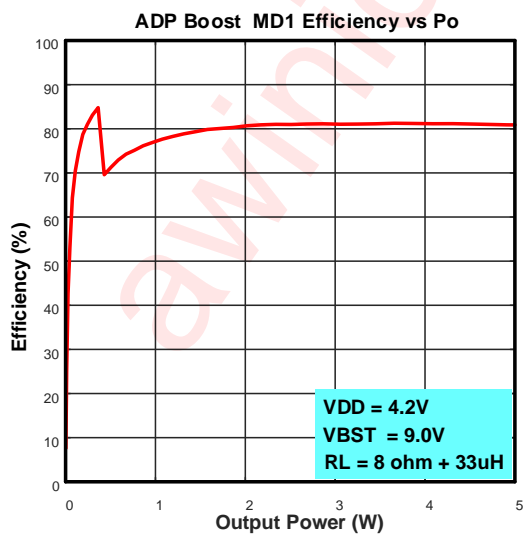
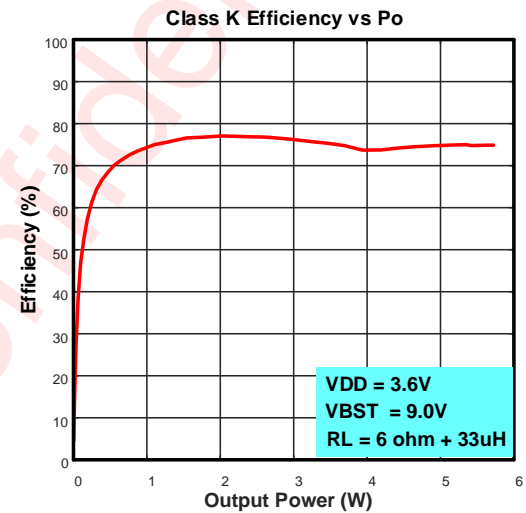
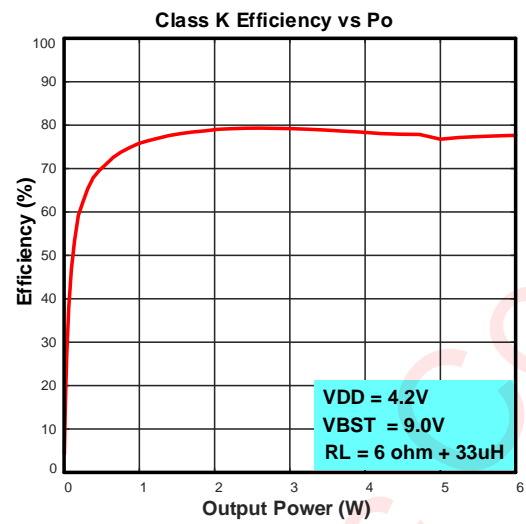
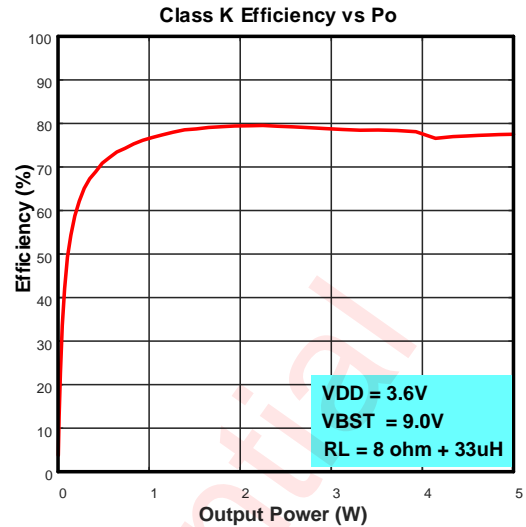
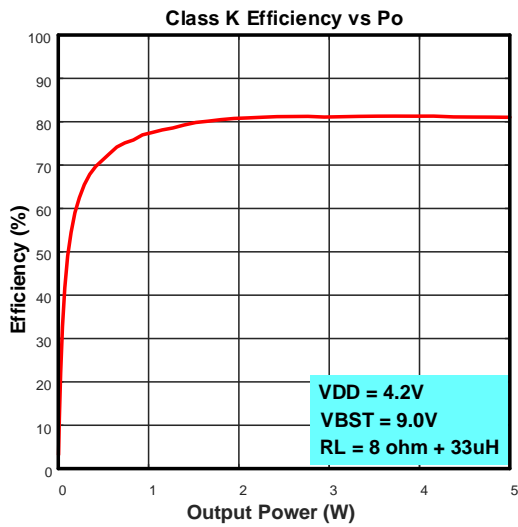

Figure 10 Output RMS Value

The power calculation of Speaker is as follows:

$$P_L = \frac{(V_{O\_rms})^2}{R_L} \quad R_L: \text{load impedance of the speaker}$$

TYPICAL CHARACTERISTICS



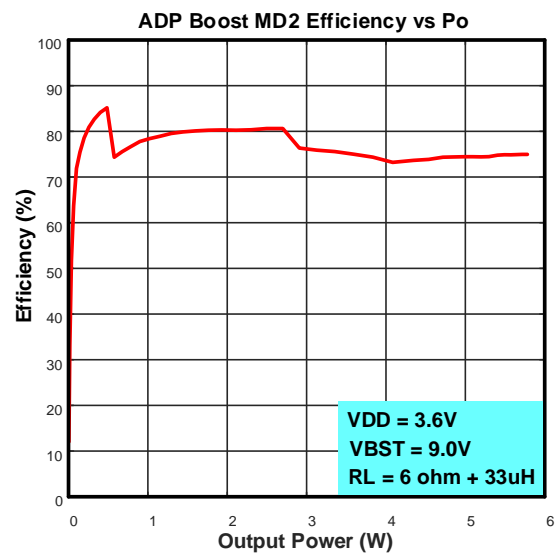
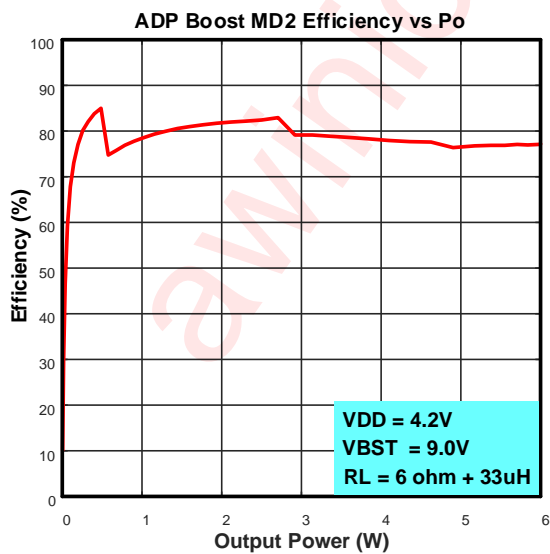
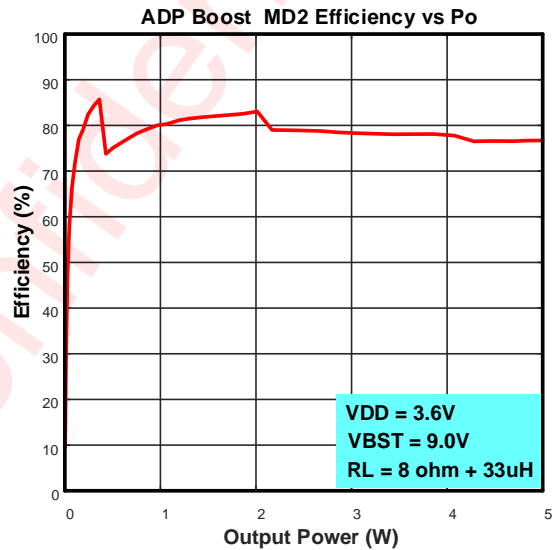
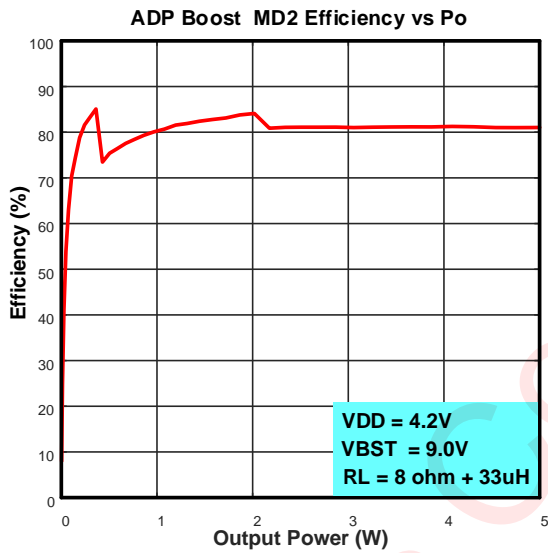
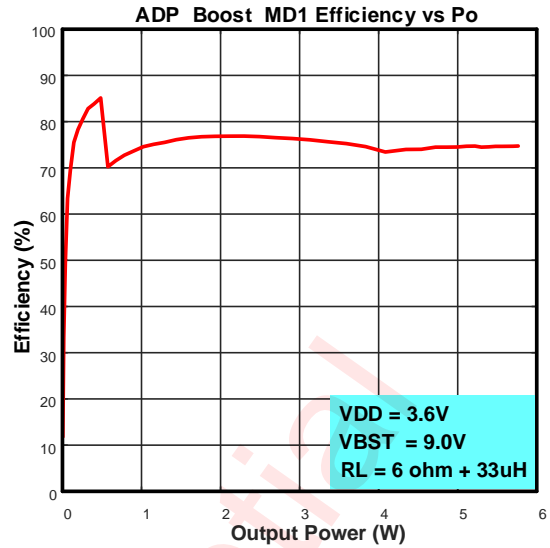
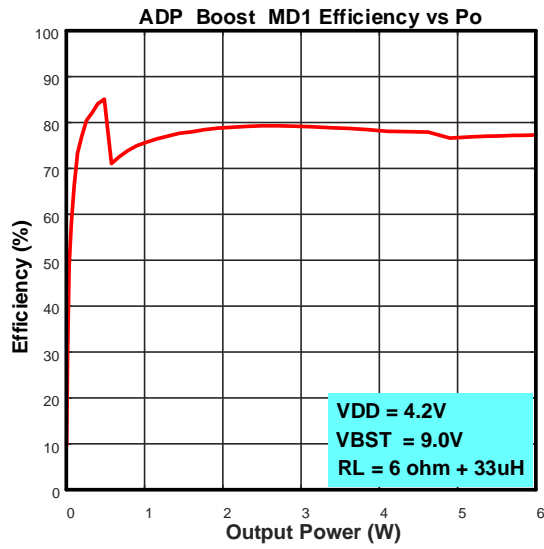

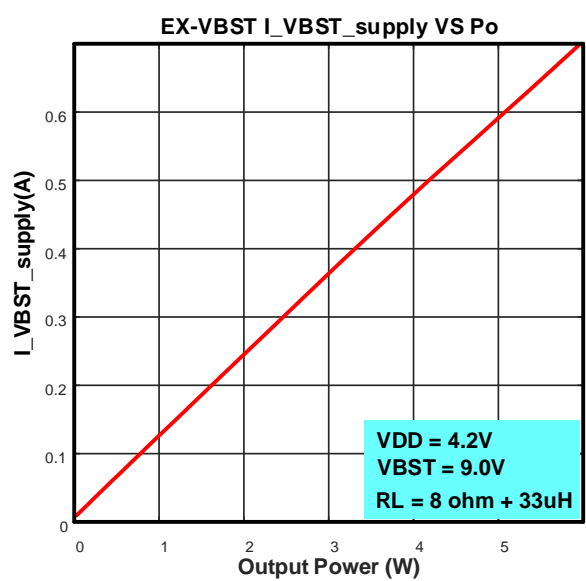
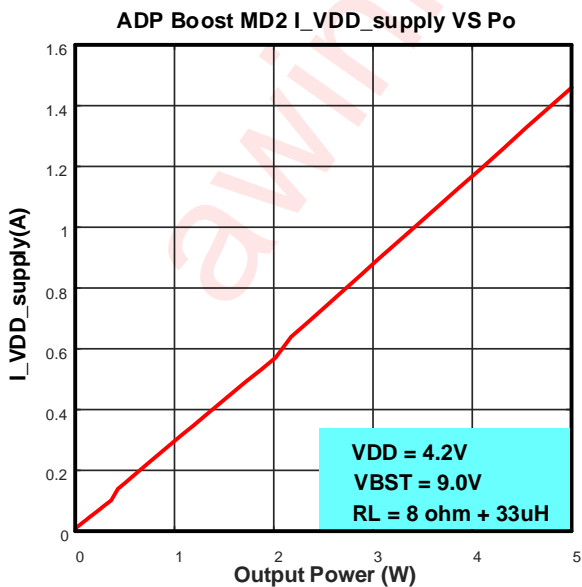
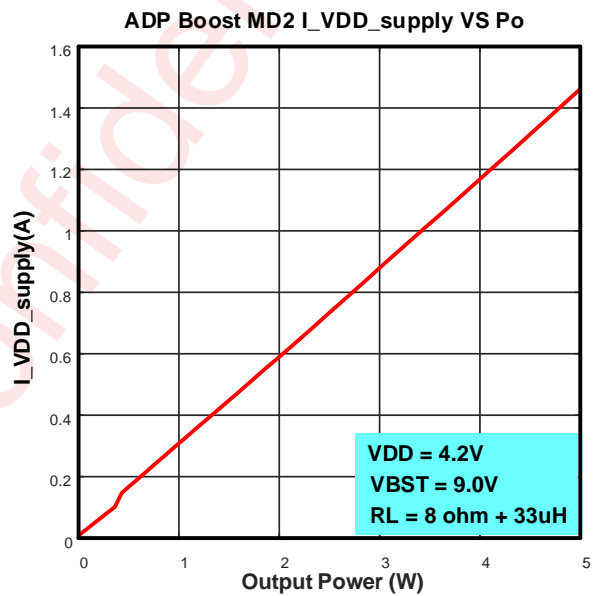
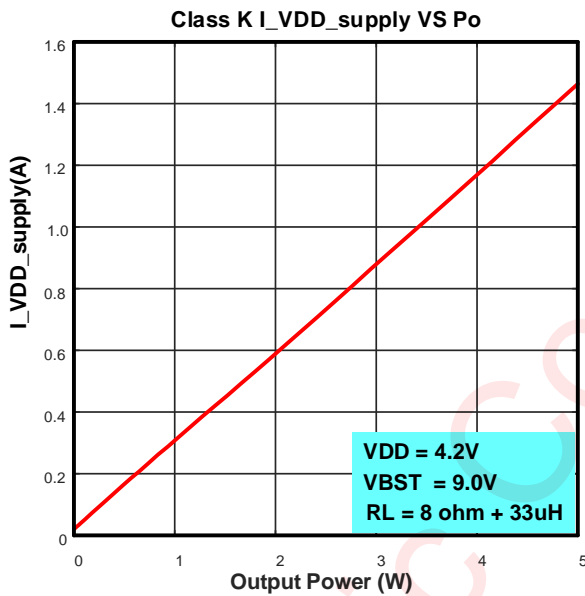
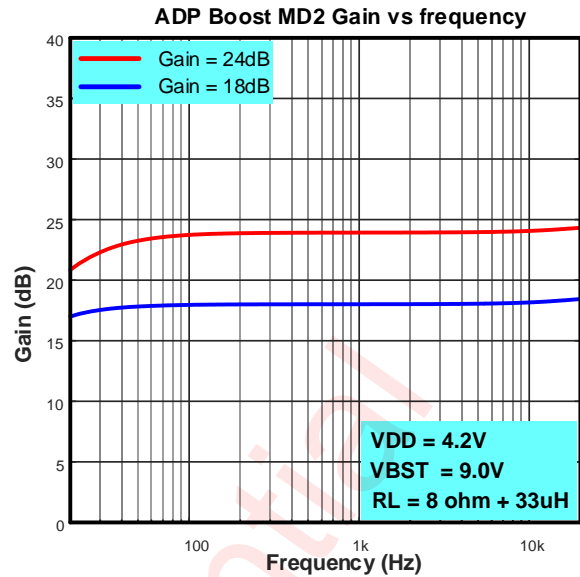
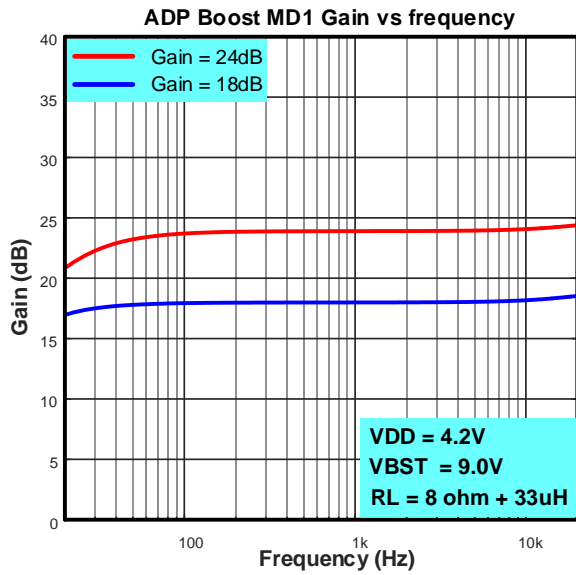

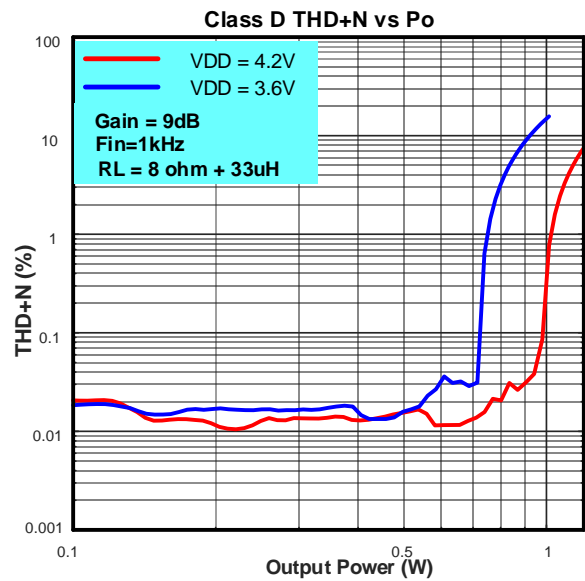
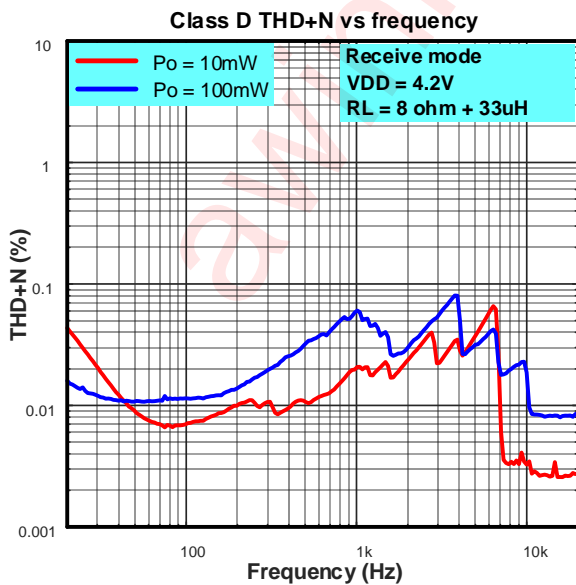
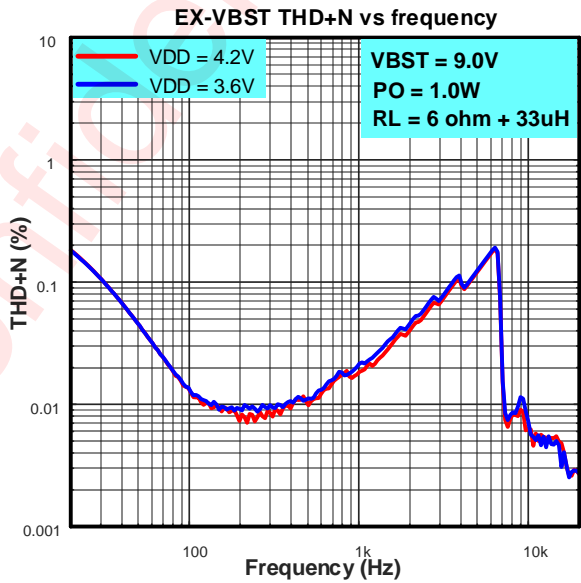
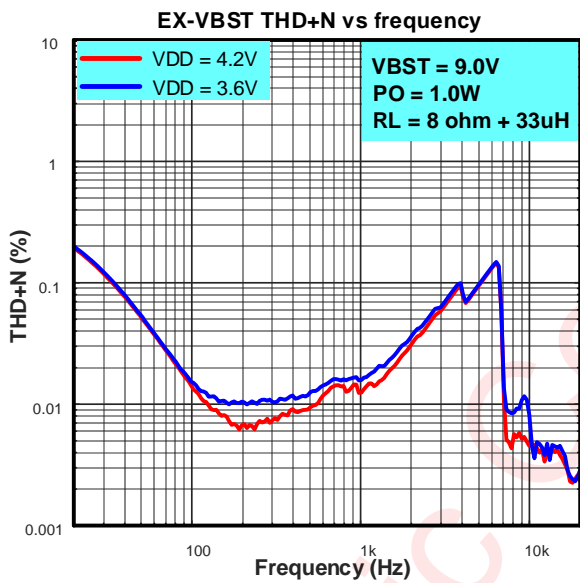
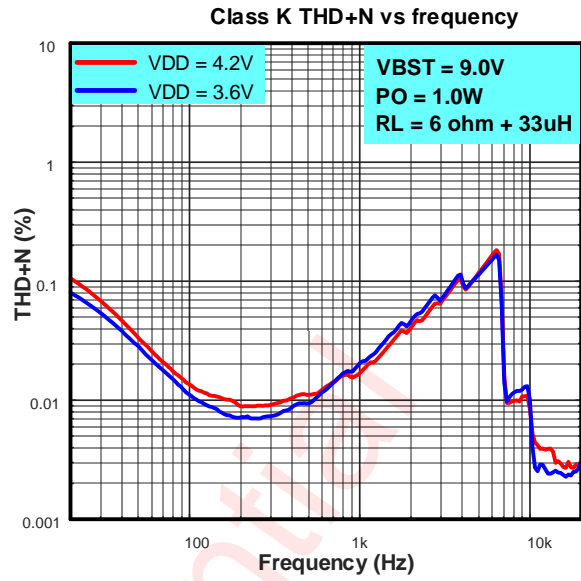
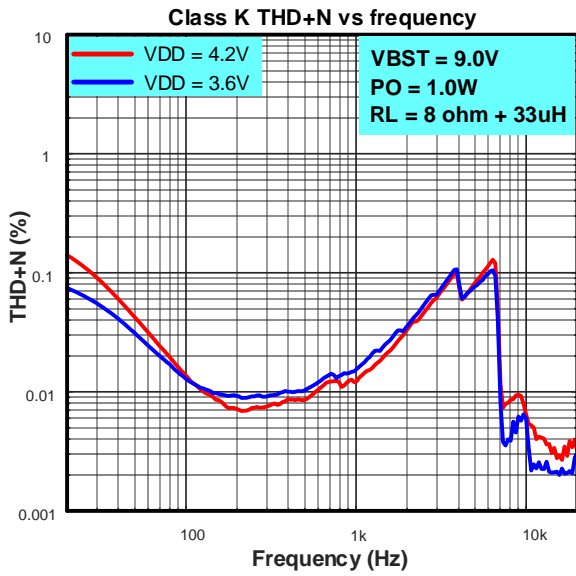

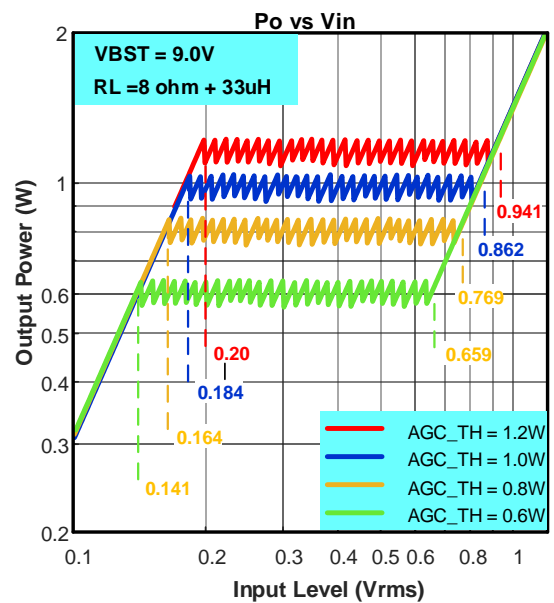
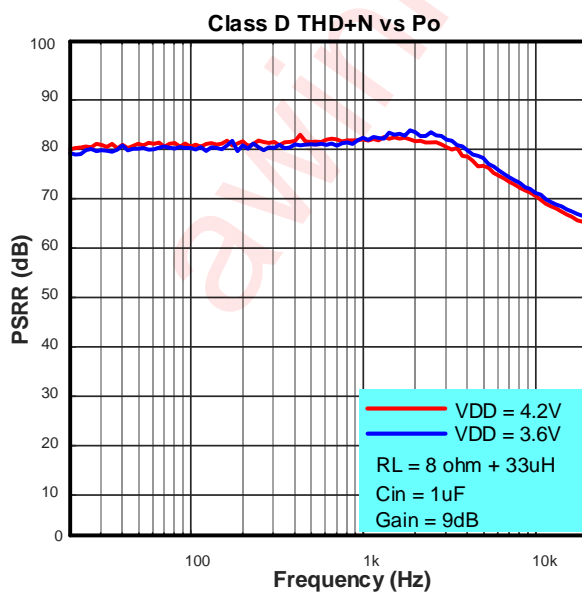
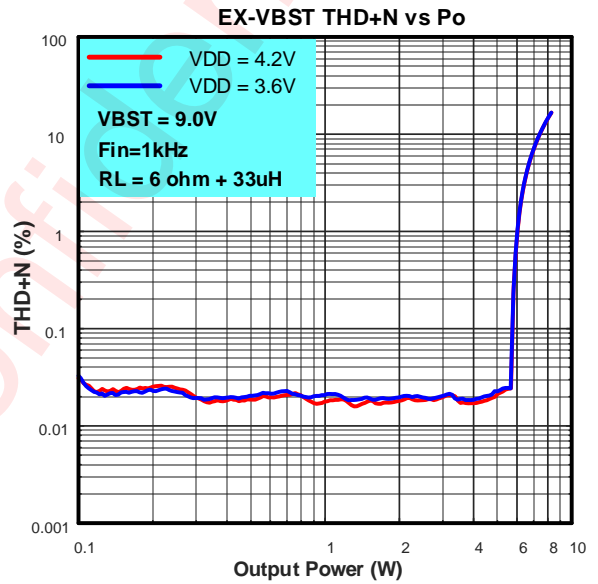
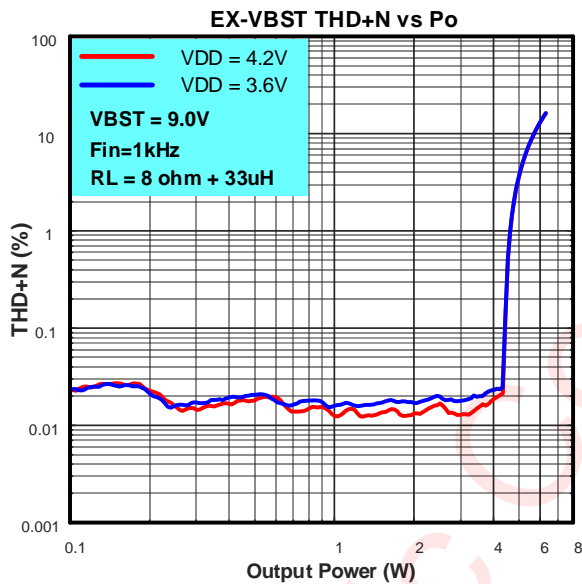
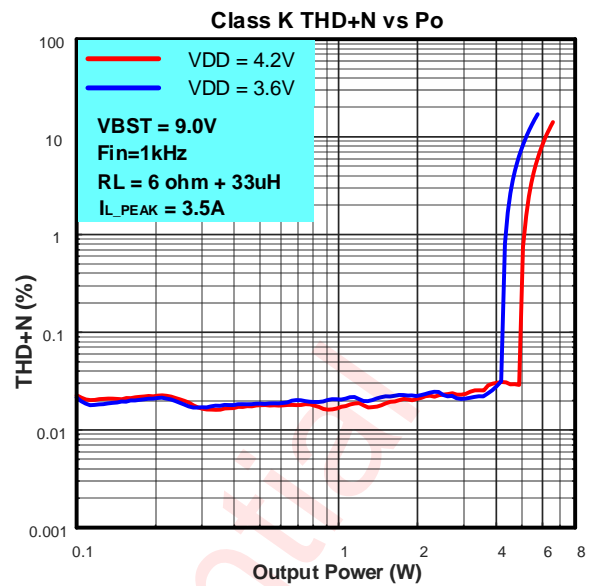
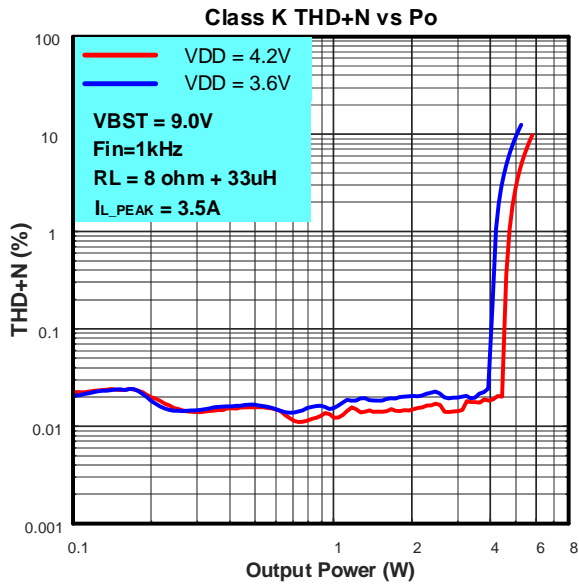

Start-up sequence

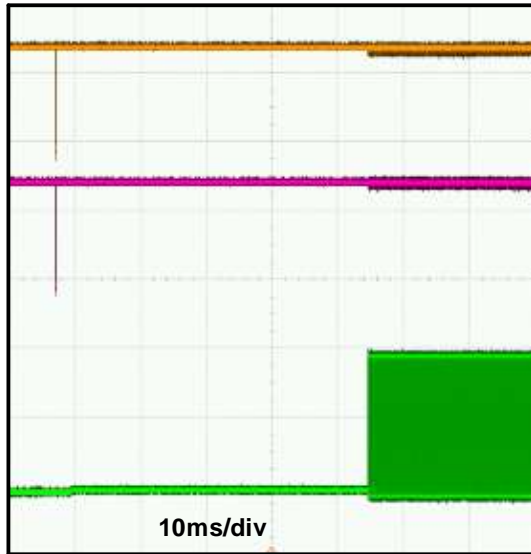

Shutdown sequence

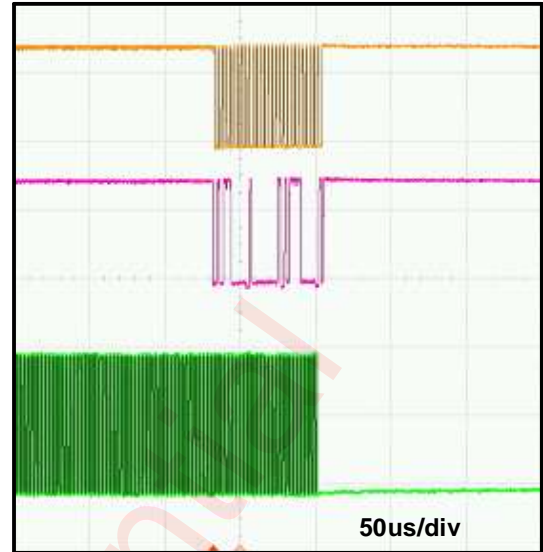

Triple-Level Triple Rate AGC Attack Timing

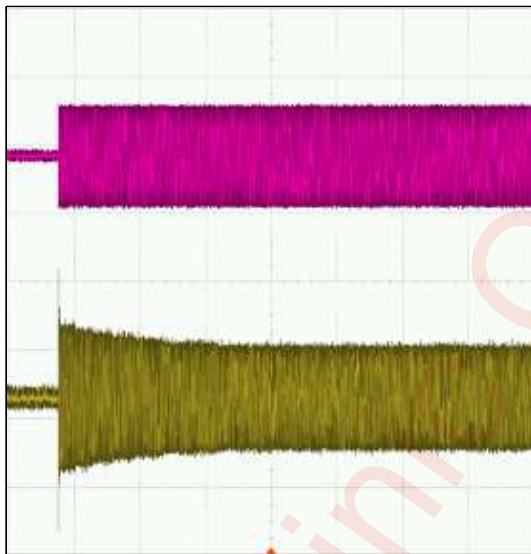

Triple-Level Triple Rate AGC Release Timing

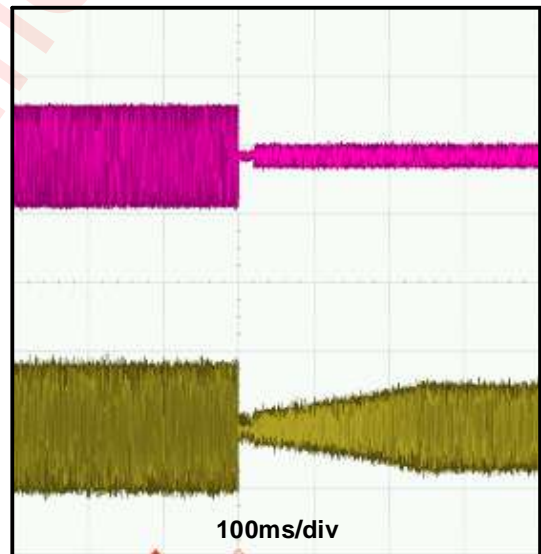

## WORKING PRINCIPLE

AW87559 is specifically designed to improve the musical output dynamic range, enhance the overall sound quality. It is a new high efficiency, high PSRR, low noise, constant large volume, 5<sup>th</sup> generation Smart K audio amplifier. AW87559 integrates AWINIC's proprietary Triple-Level Triple-Rate AGC audio algorithm, effectively eliminating music noise and improving sound quality and volume. AW87559 integrates high voltage synchronous Boost with efficiency up to 88% as the class D power stage supply, significantly improving the dynamic range of music. AW87559 noise floor is as low as to 45 $\mu$ V at speaker mode, with 103dB high signal-to-noise ratio (SNR). The ultra-low distortion 0.012% and unique Triple-Level Triple-Rate AGC technology bring high quality music enjoyment.

AW87559 supports speaker and receiver 2-in-1 application. In the receiver mode, its ultra-low noise is 11 $\mu$ V@0dB. Class D receiver also has high PSRR performance to completely suppress TDD-noise.

AW87559 controls internal registers through the I<sup>2</sup>C interface. Register parameters include boost output voltage, boost maximum input peak current, PA gain, Triple-Level Triple-Rate AGC parameters, etc.

AW87559 built-in over current protection, over temperature protection and short circuit protection function, effectively protect the chip. AW87559 features small FCQFN 2.0mmX3.0mmX0.55mm-20L package.

## CONSTANT OUTPUT POWER

In the mobile phone audio applications, the AGC function to promote music volume and quality is very attractive, but as the lithium battery voltage drops, general power amplifier output power will reduce gradually. So, it is hard to provide high quality music within the battery voltage range. AW87559 uses unique Triple-Level Triple-Rate technology, within lithium battery voltage range (3.3V~4.35V), to guarantee that output power is constant, and the output power will not drop along with the decrease of lithium battery voltage. In the process of using the phone, even if the battery voltage drops, AW87559 can still provide high quality large volume music enjoyment. The output power of AW87559 can be configured from 0.5W to 2W via I<sup>2</sup>C, matching general speakers. Unique Triple-Level Triple-Rate AGC technology can bring high-quality music enjoyment.

## TRIPLE-LEVEL TRIPLE-RATE AGC TECHNOLOGY

AWINIC proprietary Triple-Level Triple-Rate AGC technology is designed for the protection of the high voltage power amplifier, which is divided into AGC1, AGC2 and AGC3 power levels, to obtain a large volume while maintaining excellent sound quality.

In practical applications, speaker can continuously work long hours at rated power, and also can work short-term at high power. For example, in the standard reliability of the loudspeaker experiment, the power of peak power reached around four times of the rated power. For achieving larger volume and better sound quality, speakers need to work at high power for short periods of time, in order to improve the performance of the speaker. AW87559 Triple-Level Triple-Rate AGC technology can fit the speaker better and perform better overall performance. AGC1 prevents output signal clipping by detecting output voltage in a very short time after clipping, which can effectively restrain the noise clipping; AGC2 can improve the dynamic range of the music in a relatively short period of time; AGC3 can make the speaker work under rated power, which can effectively improve the volume and protect the speaker. Triple-Level Triple-Rate AGC can obtain more excellent overall performance.

Triple-Level Triple-Rate AGC detects the peak output voltage of the power amplifier, when the output peak voltage is higher than the compression threshold voltage, the amplifier gain decreases in 0.5dB step. When the output peak voltage is lower than the release threshold voltage, the amplifier gain is recovery to the initial gain in 0.5dB step. The detailed process can be described as follows:

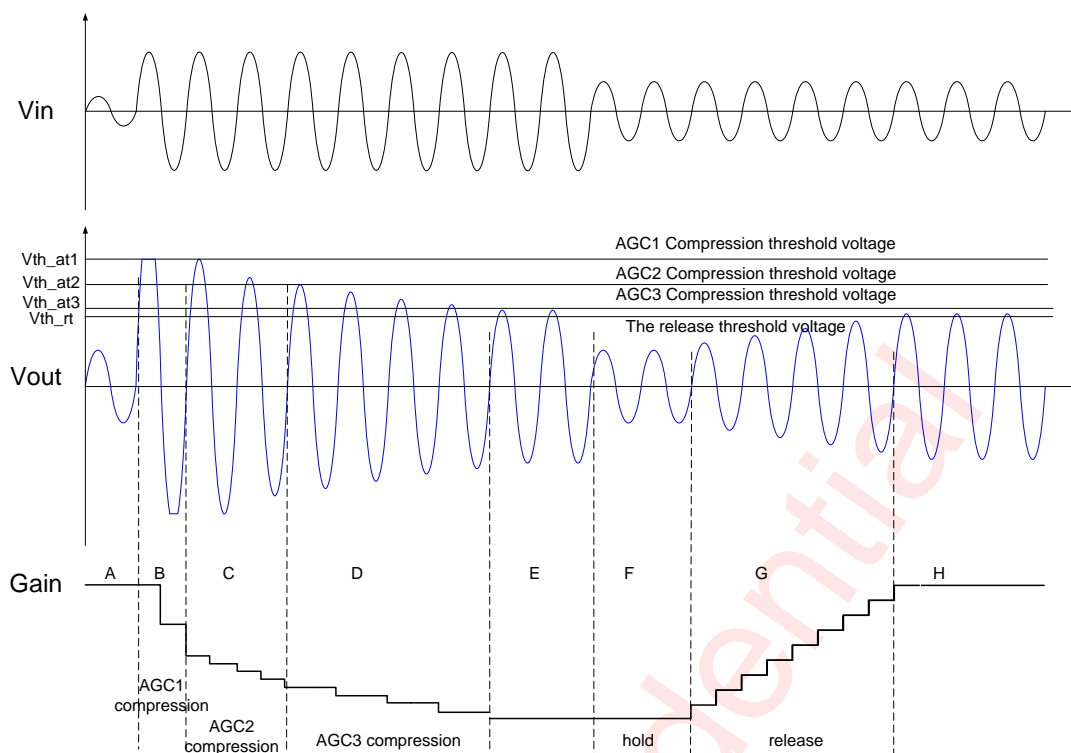

**Figure 11 Triple-Level Triple-Rate AGC Operation Principle**

**A:** Small input signal, the output voltage is lower than threshold voltage  $V_{th}$  of AGC, AGC don't work.

**B:** Input voltage becomes large. It leads to the output voltage clipping, AGC1 starts fast compression, the attack time is set through the I<sup>2</sup>C register 0x0Bh [2:1], when the output voltage is higher than  $V_{th\_at1}$ , and gain register began to decrease. Gain decreases when the output signal passes through the zero. It eliminates the clipping noise as soon as possible.

**C:** When the output voltage is not clipping and higher than threshold voltage  $V_{th\_at2}$ , AGC2 starts work, the attack time is set through the I<sup>2</sup>C register 0x0Ah [4:2], gain register begins to decrease at a certain rate. Gain register began to decrease. Gain decreases when the output signal passes through the zero. The output voltage gradually decreases to below the AGC2 attack threshold voltage  $V_{th\_at2}$ , which can protect the speaker and enhance the sound.

**D:** When the output voltage is lower than the AGC2 attack threshold voltage  $V_{th\_at2}$  and higher than the AGC3 attack threshold voltage  $V_{th\_at3}$ , AGC3 starts work, the attack time is set through the I<sup>2</sup>C register 0x08h [4:2], and gain register began to decrease at a certain rate. Gain decreases when the output signal passes through the zero, so the output voltage gradually decreases to below of the AGC3 attack threshold voltage  $V_{th\_at3}$ , matching the speaker to achieve greater volume and better sound quality.

**E:** Triple-Level Triple-Rate AGC attack time ends, Amplifier output power is close to the speaker rated power.

**F:** Input voltage decreases, the output voltage becomes lower than the release threshold voltage  $V_{th\_rt}$ , at this point, gain remains the same in the maintain time (10ms~20ms).

**G:** Gain increases when the time of output voltage lower than the release threshold voltage  $V_{th\_rt}$  is longer than the holding time. The release time can be set through I<sup>2</sup>C register 0x08h [7:5].

**H:** Stop release when the output signal is larger than the release threshold or the gain is equal to the initial value. The output voltage remains constant.

Triple-Level Triple-Rate AGC can switch independently according to different application requirements.

## ZERO-CROSSING ADJUSTMENT TECHNOLOGY

Traditional AGC doesn't contain zero adjustment technology; AGC gain changes generally at the peak, the gain variation at the peak would generate a certain transient distortion, such distortions are audibly imperceptible. Such as individual songs have a slight click.

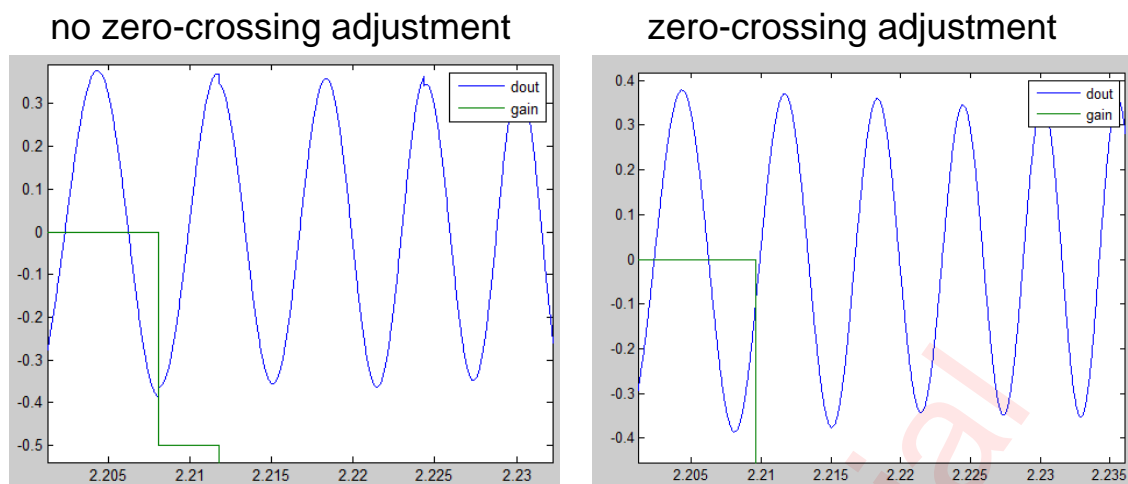

**Figure 12 Zero-adjust Comparison**

As shown above, when there is no zero-adjustment technology, it can be seen the obvious step change at the peak of large signal, the steps sound slightly perceived in special audio. Gain changes at zero. The steps disappear by using zero-crossing detection technology. Using zero detection technology can make the music pure and natural.

## LOW-VOLTAGE PROTECTION AGC TECHNOLOGY

Mobile phone battery voltage will decrease in use, but the current will increase. When the battery voltage is low, high current maybe cause the battery protection or mobile phone automatically shut down. AWINIC proprietary low voltage protection AGC technology can solve the problems, to prevent high current when the battery voltage is too low.

AW87559 is built-in low voltage protection AGC technology to real-time detection the battery voltage. Gain decreases rapidly when the battery voltage is below the safety threshold, so as to decrease the output voltage and the power supply current, which effectively prevents high current.

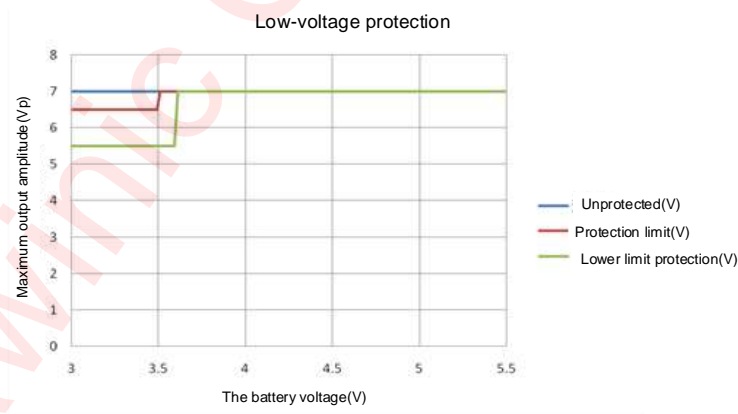

**Figure 13 Low voltage protection**

The protection safety threshold voltage is set to 3.3V~3.6V through the I<sup>2</sup>C register 0x02h [4:3]. The maximum protection output voltage is set to 5Vp ~ 6.5Vp through I<sup>2</sup>C register 0x02h [1:0].

Only when the register 0x02h [2] is set to 1, low voltage protection AGC technology is enabled.

## SYNCHRONOUS ADAPTIVE BOOST TECHNOLOGY

AW87559 integrated peak current mode synchronous adaptive PWM Boost as Class D power stage supply, significantly increase the output voltage dynamic range. Reduces the size of external components and saves PCB space by using 1.6MHz switching frequency. The boost converter is adaptive and activates automatically

depending on the output audio signal amplitude. As the audio output is higher than the first prescribed value SET\_BOOST\_VTH1, which can be set through the I<sup>2</sup>C register 0x0Fh [2:0], the Boost enters into MODE1, where the boost regulator is activated to boost and regulate VBST at an intermediate value. As the audio output grows higher than the second prescribed value SET\_BOOST\_VTH2, which can be set through the I<sup>2</sup>C register 0x0Fh [5:3], The Boost enters into MODE2, the Boost enters into MODE2, where VBST is further boosted and regulated at its final value set by BST\_VOOUT, which can be set through the I<sup>2</sup>C register 0x03h [4:0], Boost current limit can be set through register 0x05h [3:0].

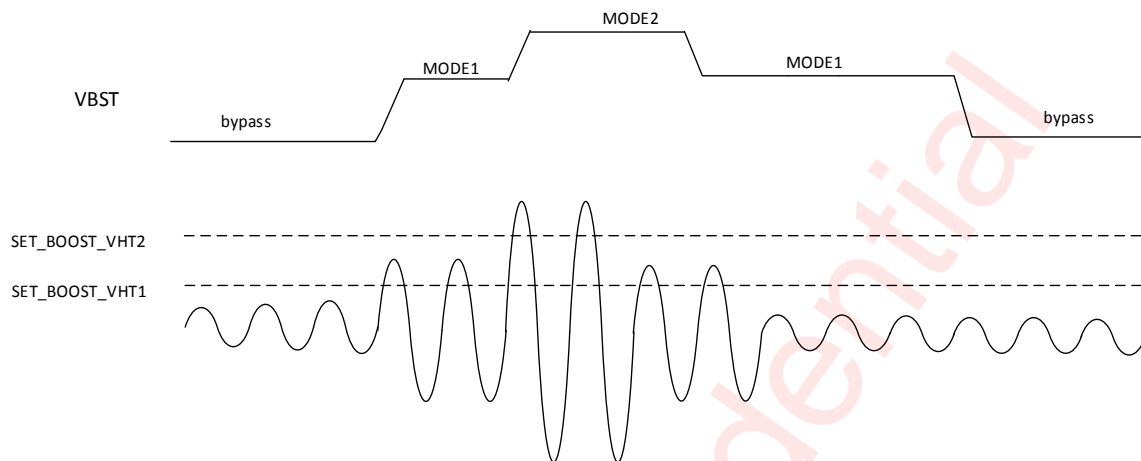

Figure 14 Adaptive Boost Operation Principle

## SPEAKER & RECEIVER 2-in-1

AW87559 built-in speaker and receiver 2-in-1 application mode, through the register settings, class D-type 2-in-1 receiver mode gain can be adjusted through the I<sup>2</sup>C register 0x05, adjustable range of 0~10.5dB, the application is very flexible. The 2-in-1 receiver mode uses the signal path of the speaker, with ultra-low distortion and strong drive capability, and eliminates the need for additional peripheral components, saving system cost and PCB layout space.

In the typical application case of Figure 8, the input capacitance  $C_{in} = 68\text{nF}$ , the gain is 24dB in the speaker application mode, the input high-pass cutoff frequency is 260Hz; In 9dB gain class D-type 2-in-1 receiver application mode, the output noise is 19 $\mu\text{V}$ , the input high-pass cut-off frequency is 62Hz, which is very suitable for high-definition voice applications. AW87559 can achieve speaker and receiver's 2-in-1 application without changing any hardware in the case.

## RNS (RF TDD NOISE SUPPRESSION)

### TDD NOISE CAUSES

GSM cell phones use TDMA (Time Division Multiple Access) slot sharing technology. The time is divided into periodic frames in TDMA, and each frame is subdivided into a plurality of time slots. In order to transmit signals to the base station, the signals sent from the base stations to the plurality of mobile terminals are arranged in a predetermined time slot in the transmission. In this case, each TDMA frame contains 8 time slots, the entire frame is about 4.615ms long, and each slot time is 0.577ms.

With GSM handset, the RF power amplifier will transmit once every 4.615ms (217Hz), and the signal will produce intermittent Burst current and strong electromagnetic radiation. Intermittent Burst current will form a power fluctuation of 217 Hz; High frequency (900MHz and 1800MHz) RF signals form a 217Hz RF envelope signal. 217Hz power fluctuations will be conducted through the conduction to the audio signal path, 217Hz RF envelope signal will be coupled through the radiation into the audio signal path, if the protection is not good, it will produce an audible TDD Noise, which includes the 217Hz noise And a harmonic noise signal of 217 Hz.

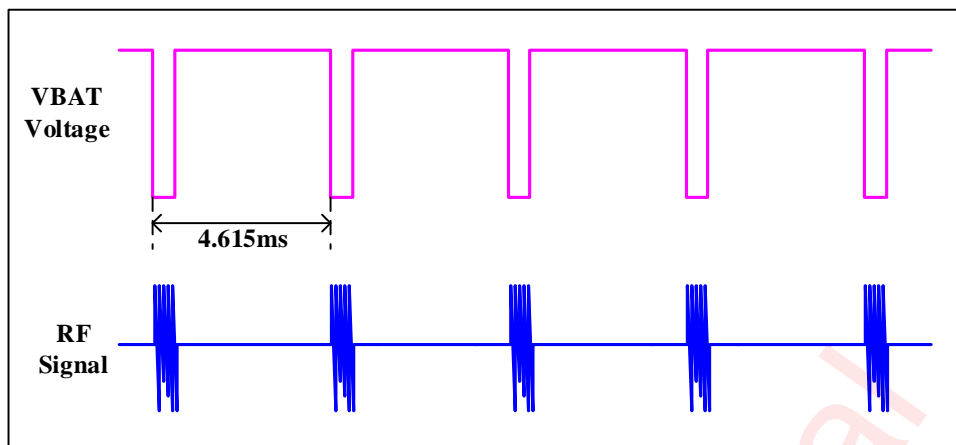

**Figure 15 Schematic Diagram of Power Supply Voltage and RF Signal during GSM RF Operation**

RNS fully inhibit the conduction and radiation interference by the AWINIC unique circuit architecture. Effectively improve the ability to suppress TDD Noise.

### **CONDUCTION NOISE SUPPRESSION**

When the RF power amplifier is operating, it will draw the current from the battery by 217Hz frequency, Power supply will be introduced to 217Hz power ripple since the battery has a certain internal resistance, it will be coupled to the speaker through the audio power amplifier. The ability to suppress power fluctuations depends on the PSRR of the audio power amplifier.

$$PSRR = 20\log\left(\frac{v_{ddac}}{v_{outac}}\right)$$

Due to the input and output of the fully differential amplifier is perfectly symmetrical, theoretically, the effect of the power supply fluctuation on the two outputs is exactly the same, and the differential output is completely unaffected by the power supply fluctuation. In practice, due to process bias and other factors, the amplifier will have a certain mismatch, PSRR is generally better than 60dB, it shows the output relative to the power fluctuations can be reduced by 1000 times, such as 500mVp power fluctuations, the differential output of 0.5 mV, which basically can meet the application requirements.

But in practical applications, the power amplifier may encounter conduction of TDD Noise problem even if its PSRR is 60dB or 80dB, why is this? Because we also need to consider the impact of peripheral power mismatches of audio power amplifiers.

For conventional audio power amplifiers, when the input resistor  $R_{in}$  and the input capacitor  $C_{in}$  mismatch, will greatly affect the audio power amplifier PSRR indicators, in the case of 24 times the gain, PSRR will be weakened to 46dB or so if the input resistance and Capacitor with 1% mismatch. PSRR will be weakened to 28dB or so if the input resistance and input capacitance mismatch with 10% mismatch, when the power fluctuations, it is easy to produce audible TDD Noise.

In order to enhance the audio power amplifier PSRR in the input resistance and input capacitance mismatch case, AW87559 features a unique conduction noise suppression circuit, making the power amplifier to maintain a high PSRR value even in the input resistance, the input capacitance deviation of 10% or more, this greatly inhibits the generation of conducted noise.

### **RADIATION NOISE SUPPRESSION**

Input traces, output traces, horn loops, and even power and ground loops are likely to be subject to RF radiation interference in the audio signal module, longer input traces and output traces similar to the antenna, especially vulnerable RF radiation effects.

The reasonable PCB layout can reduce the influence of RF radiation in the design, such as shorten the line length of input and output as much as possible; audio devices should be shielded and far away from the RF antenna, maintain the integrity of the device to audio signal pathway; to increase the small bypass capacitor

RF signals in the sensitive nodes. However, in practical applications, PCB layout is difficult to fully consider the influence of RF radiation on the audio signal path, and some RF energy will still be coupled to the audio signal path to form audible TDD Noise. Therefore, AW87559 features a unique RF radiation suppression circuit, a shielding layer inside the chip, effectively prevent high frequency energy into RF chip, to ensure that the drive single of the amplifier provided to the speaker will not be affected by the antenna RF radiation, thus avoiding the antenna RF Radiation caused by TDD Noise.

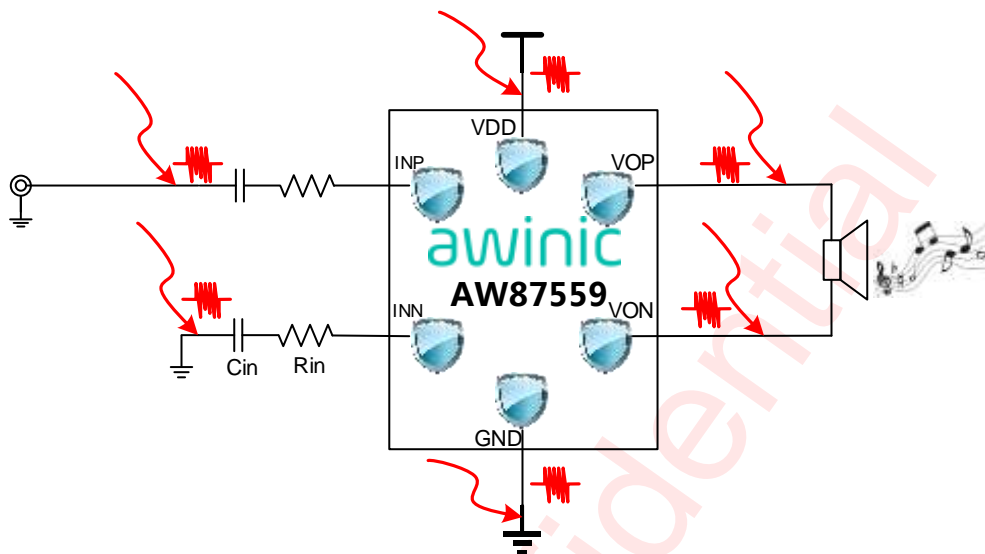

Figure 16 RF Radiation Coupling Graph

## CLASS D AMPLIFIER WITHOUT FILTER

When the traditional Class D amplifier is in idle state of no input signal, the output will have the inverse square wave, it will directly above the load of the speaker, will form a large current power switch on the speaker, therefore we need to increase the LC filter to restore the analog audio signal at the amplifier output. The LC filter increase the cost and PCB layout area, while increase the power consumption, reduce the performance of THD+N.

The AW87559 features a Class D amplifier without a filter, eliminating the need for an output LC filter. In the idle state of no input signal, the two outputs (VOP, VON) of the amplifier are in-phase square waves and not generate idle switching currents on the speaker load. When the input signal is added to the input terminal, the duty ratio of the output is changed. The duty cycle of the VOP becomes larger and the duty cycle of the VON becomes smaller, and the difference value of the output forms the differential amplified signal on the speaker.

## EEE

The AW87559 features a unique Enhanced Emission Elimination (EEE) technology, that controls fast transition on the output, greatly reduces EMI over the full bandwidth, fully meet FCC Class B specification requirements.

## POP-CLICK SUPPRESSION

The AW87559 features unique timing control circuit, that comprehensively suppresses pop-click noise, eliminates audible transients on shutdown, wakeup, and power-up/down.

## THERMAL AGC/OVER TEMPERATURE PROTECTION

The AW87559 features the thermal AGC patented technology, can according to the chip temperature, automatically adjust the gain of the system, reduce the power consumption of the chip, to prevent damage in case of excessive temperature.

The AW87559 has an automatic temperature detection mechanism, when the chip temperature exceeds the preset threshold of thermal AGC temperature (150°C), the chip will start the automatic gain control circuit to

decrease the gain of the system, thereby reducing the energy consumption of the chip, thus slow or stop chip temperature continues to rise. When the chip temperature is restored to normal operating range (below 130°C), the automatic gain control circuit will restore the system gain to the original state. When the chip operates in a fault condition, the chip temperature is too high, up to a preset temperature protection temperature threshold (160°C), the system starts overheating protection, the chip will be turned off, restarts to resume normal work when the chip temperature returns to normal operating range (less than 130°C).

## **AUTOMATIC RECOVERY OF OVERCURRENT PROTECTION**

AW87559 with automatic recovery of the output overcurrent protection function, when the overcurrent occurs, AW87559 internal protection circuit will chip off to ensure that the chip is not damaged, when the short-circuit fault is eliminated, the chip will automatically resume working without restarting.

awinic Confidential

## DEVICE ADDRESS

The I<sup>2</sup>C device address (7-bit) is decided by the connection of the AD pin. The connection of AD pin configures the two LSB bits of the following 7-bit binary address A6-A0 of 10110A1A0. The permitted I<sup>2</sup>C addresses are 0x58(7bit) through 0x5B (7-bit). The address information is as following table.

AD pin	A1	A0	I <sup>2</sup> C address (7-bit)
Connects to GND	0	0	0x58
Connects to SCL	0	1	0x59
Connects to SDA	1	0	0x5A
Connects to VDD	1	1	0x5B

Table 2 AW87559 Address selection

## I<sup>2</sup>C TIMING FEATURE

Parameter			MIN	TYP	MAX	UNIT
No.	Sym	Name				
1	f <sub>SCL</sub>	SCL Clock frequency			400	kHz
2	t <sub>LOW</sub>	SCL Low level Duration	1.3			μs
3	t <sub>HIGH</sub>	SCL High level Duration	0.6			μs
4	t <sub>RISE</sub>	SCL, SDA rise time			0.3	μs
5	t <sub>FALL</sub>	SCL, SDA fall time			0.3	μs
6	t <sub>SU:STA</sub>	Setup time SCL to START state	0.6			μs
7	t <sub>HD:STA</sub>	(Repeat-start) Start condition hold time	0.6			μs
8	t <sub>SU:STO</sub>	Stop condition setup time	0.6			μs
9	t <sub>BUF</sub>	the Bus idle time START state to STOP state	1.3			μs
10	t <sub>SU:DAT</sub>	SDA setup time	0.1			μs
11	t <sub>HD:DAT</sub>	SDA hold time	10			ns

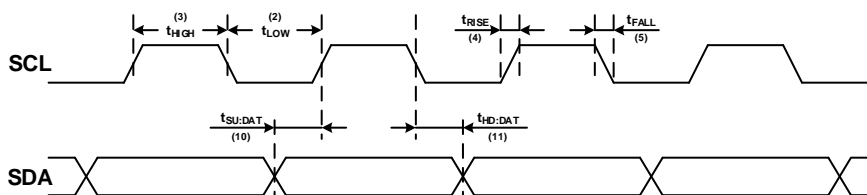

Figure 17 SCL and SDA timing relationships in the data transmission process

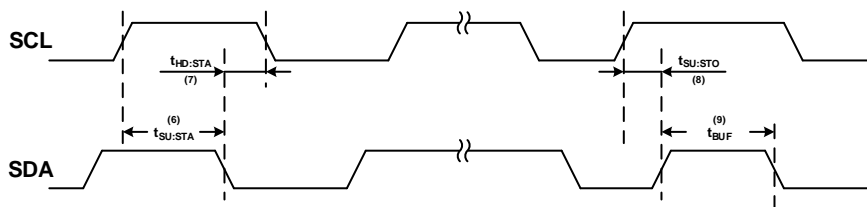

Figure 18 the Timing Relationship between START and STOP State

## GENERAL I<sup>2</sup>C OPERATION

The I<sup>2</sup>C bus employs two signals, SDA (data) and SCL (clock), to communicate between integrated circuits in a system. The device is addressed by a unique 7-bit address; the same device can send and receive data. In addition, Communications equipment has distinguish master from slave device: In the communication process, only the master device can initiate a transfer and terminate data and generate a corresponding clock signal. The devices using the address access during transmission can be seen as a slave device.

SDA and SCL connect to the power supply through the current source or pull-up resistor. SDA and SCL default is a high level. All data to start transmission and end of transmission requires the main device to issue START state and STOP status:

START state: The SCL maintain a high level, SDA from high to low level

STOP state: The SCL maintain a high level, SDA pulled low to high level

Start and Stop states can be only generated by the master device. In addition, if the device does not produce STOP state after the data transmission is completed, instead re-generate a START state (Repeated START, Sr), and it is believed that this bus is still in the process of data transmission. Functionally, Sr state and START state is the same. As shown in Figure 19.

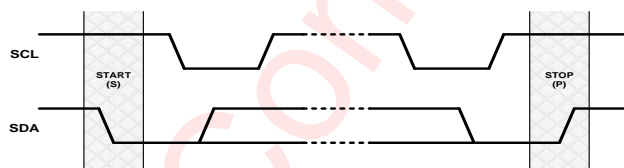

Figure 19 START and STOP State Generation Process

In the data transmission process, when the clock line SCL maintains a high level, the data line SDA must remain the same. Only when the SCL maintain a low level, the data line SDA can be changed, as shown in Figure 19. Each transmission of information on the SDA is 9 bits as a unit. The first eight bits are the data to be transmitted, and the first one is the most significant bit (Most Significant Bit, MSB), the ninth bit is an acknowledgment bit (Acknowledge, ACK or A), as shown in Figure 21. When the SDA transmits a low level in ninth clock pulse, it means the acknowledgment bit is 1, namely the current transmission of 8 bits data are confirmed, otherwise it means that the data transmission has not been confirmed. Any amount of data can be transferred between START and STOP state.

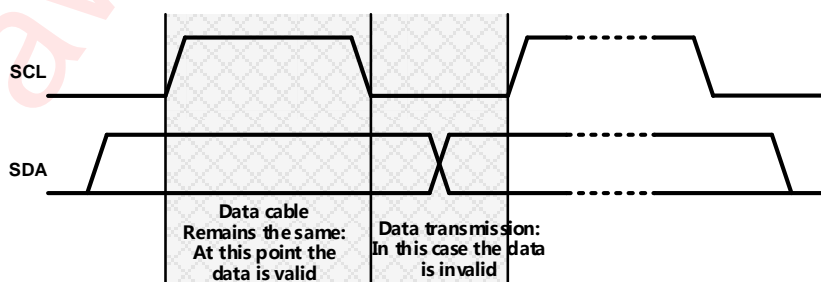

Figure 20 Data Transfer Rules on the I<sup>2</sup>C Bus

The whole process of actual data transmission is shown in Figure 21. When generating a START condition, the master device sends an 8-bit data, including a 7-bit slave addresses (Slave Address), and followed by a

"read / write" flag ( $R/\overline{W}$ ). The flag is used to specify the direction of transmission of subsequent data. The master device will produce the STOP state to end the process after the data transmission is completed. However, if the master device intends to continue data transmission, you can directly send a Repeated START state, without the need to use the STOP state to end transmission.

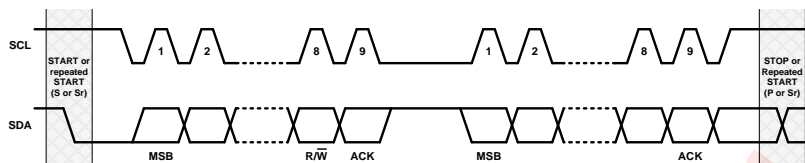

Figure 21 Data Transmission on the I<sup>2</sup>C Bus

## I<sup>2</sup>C READ/WRITE PROCESSES

The following describes two kinds of ways of the I<sup>2</sup>C bus data transmission:

### WRITE PROCESS

Writing process refers to the master device write data into the slave device. In this process, the transfer direction of the data is always unchanged from the master device to the slave device. All acknowledge bits are transferred by the slave device, in particular, AW87559 as the slave device, the transmission process in accordance with the following steps, as shown in Figure 22:

Master device generates START state. The START state is produced by pulling the data line SDA to a low level when the clock SCL signal is a high level.

Master device transmits the 7-bits device address of the slave device, followed by the "read / write" flag (flag  $R/\overline{W} = 0$ );

The slave device asserts an acknowledgment bit (ACK) to confirm whether the device address is correct;

The master device transmits the 8-bit AW87559 register address to which the first data byte will written;

The slave device asserts an acknowledgment (ACK) bit to confirm the register address is correct;

Master sends 8 bits of data to register which needs to be written;

The slave device asserts an acknowledgment bit (ACK) to confirm whether the data is sent successfully;

If the master device needs to continue transmitting data, it does not need further to send the register address for AW87559, within AW87559 each send confirmation bit(ACK) regret automatic accumulation register address then only need to repeat the sixth step and seven step:

The master device generates the STOP state to end the data transmission.

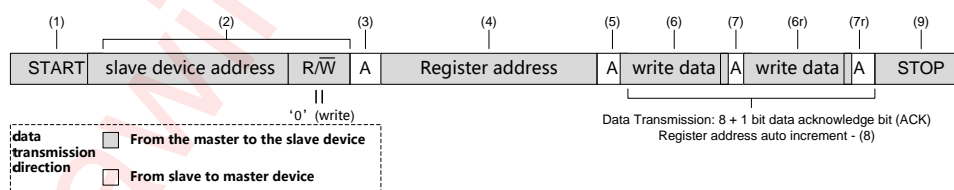

Figure 22 Writing Process (Data Transmission Direction Remains the Same)

### READ PROCESS

Reading process refers to the slave device reading data back to the master device. In this process, the direction of data transmission will change. Before and after the change, the master device sends START state and slave address twice, and sends the opposite "read/write" flag. In particular, AW87559 as the slave device, the transmission process carried out by following steps listed in Figure 23:

Master device asserts a start condition;

Master device transmits the 7 bits address of AW87559, and followed by a "read / write" flag ( $R/\bar{W}=0$ );  
 The slave device asserts an acknowledgment bit (ACK) to confirm whether the device address is correct;  
 The master device sends the 8bit address that the AW87559 register needs to read the data;  
 The slave device asserts an acknowledgment (ACK) bit to confirm whether the register address is correct or not;  
 The master device restarts the data transfer process by continuously generating STOP state and START state or a separate Repeated START.  
 Master sends 7-bits address of the slave device and followed by a read / write flag (flag  $R/\bar{W}=1$ ) again.  
 The slave device asserts an acknowledgment (ACK) bit to confirm whether the register address is correct or not.  
 The slave device transmits 8 bits of data to register which needs to be read;  
 The master device sends an acknowledgment bit (ACK) to confirm whether the data is sent successfully.  
 AW87559 automatically increment register address once after the slave sent each acknowledge bit (ACK).  
 The master device generates the STOP state to end the data transmission.

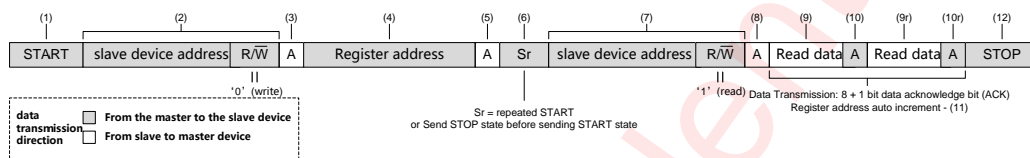

Figure 23 Reading Process (Data Transmission Direction Remains the Same)

## REGISTER LIST

ADDR	NAME	Bit7	Bit6	Bit5	Bit4	Bit3	Bit2	Bit1	Bit0	Default
0x00	ID	IDCODE								0x5A
0x01	SYCTRL	-	EN_SW	-	EN_BOOST	EN_PA	RCV_MODE	-	EN_HVBAT	0x78
0x02	BATSAFE	-	BAT_SFGD_DEGLITCH	BAT_SFGD_VTH		EN_BAT_SFGD	BAT_SFGD_LEVEL			0x09
0x03	BSTOVR	-			BST_VOUT					0x0A
0x04	-	-								0x02
0x05	BSTCPR2	-			BST_IPEAK					0x08
0x06	PAGR	-			PA_GAIN					0x10
0x07	PAGC3OPR	-			PD_AGC3	AGC3_OUTPUT_POWER				0x83
0x08	PAGC3PR	AGC3_REL_TIME			AGC3_ATT_TIME			-		0x4E
0x09	PAGC2OPR	-			AGC2_OUTPUT_POWER				0x03	
0x0A	PAGC2PR	-			AGC2_ATT_TIME			-		0x08
0x0B	PAGC1PR	-			AGC1_ATT_TIME		PD_AGC1			0x4A
0x0C	ADP MODE	-			AGC1_ATT_TIMEA	ADPBOOST_MODE			0x03	
0x0D	ADPBST TIME1	ADP_BST_TIME2			ADP_BST_TIME1				0x77	
0x0E	ADPBST TIME2	-								0x7A
0x0F	ADPBST VTH	ADP_LOW_STEP	SET_BOOST_VTH2			SET_BOOST_VTH1				0x23

Any register address which is more than 0x0A and all reserved bits are reserved for debugging and testing purposes. Changing their values may affect the normal function of the power amplifier; Reading them will get any possible values. AW87559's I<sup>2</sup>C address is 10110A2A1, as shown in Table 3, in order to avoid conflict with other I<sup>2</sup>C devices address, you can connect AD pin to GND, SCL, SDA, VDD to set the value of A2 and A1, respectively. The following lists specific information about all visible registers, including default values and programmable ranges.

Bit7	Bit6	Bit5	Bit4	Bit3	Bit2	Bit1	Bit0
1	0	1	1	0	A2	A1	R/W

Table3 AW87559 Address Byte

## CHIP ID REGISTER (ADDRESS: 0x00)

I <sup>2</sup> C Bit	Name	R/W	Default	Description
7:0	IDCODE	R	0x5A	Chip ID will be returned after reading.

## SYSTEM CONTROL (SYCTRL) REGISTER (ADDRESS: 0x01)

Bit	Symbol	R/W	Description	Default
7	Reserved	RW	Not used	0
6	EN_SW	RW	Chip software Enable	1
			0: Disable 1: Enable	
5	Reserved	RW	Reserved	1
4	EN_BOOST	RW	Boost Enable.	1
			0: Disable 1: Enable	
3	EN_PA	RW	PA Enable.	1
			0: Disable 1: Enable	
2	RCV_MODE	RW	Receiver mode	0
			0: Disable 1: Enable	

1	Reserved	RW	Reserved	0
0	EN_HVBAT	RW	Enable high voltage battery	0
			0: Disable	
			1: Enable	

**BATTERY SAFEGUARD (BATSAFE) REGISTER (ADDRESS: 0x02)**

Bit	Symbol	R/W	Description	Default
7	Reserved	RW	Not used	0
6:5	BAT_SFGD_DEGLITCH	RW	Battery safe guard deglitch time.	00
			00: 1ms	
			01: 500us	
			10: 200us	
			11: Disable	
4:3	BAT_SFGD_VTH	RW	Battery voltage when enter into battery safe_guard mode.	01
			00: 3.3V	
			01: 3.4V	
			10: 3.5V	
			11: 3.6V	
2	EN_BAT_SFGD	RW	Software control battery safeguard 0: Disable 1: Enable	0
1:0	BAT_SFGD_LEVEL	RW	Maxim output level when enter into battery safe_guard mode	01
			00: 5V	
			01: 5.5V	
			10: 6V	
			11: 6.5V	

**BOOST OUTPUT VOLTAGE (BSTVOUT) REGISTER (ADDRESS: 0x03)**

Bit	Symbol	R/W	Description	Default
7:5	Reserved	RW	Not used	000
4:0	BST_VOUT	RW	BOOST output voltage set	01010
			00000: 6.5V	
			00001: 6.75V	
			00010: 7.0V	
			00011: 7.25V	
			00100: 7.5V	
			00101: 7.75V	
			00110: 8.0V	
			00111: 8.25V	
			01000: 8.5V	
			01001: 8.75V	
			01010: 9.0V	

**BOOST PARAMETER REGISTER (ADDRESS: 0x04)**

Bit	Symbol	R/W	Description	Default
7:0	Reserved	RW	Not used	00000010

**BOOST CONTROL REGISTER (ADDRESS: 0x05)**

Bit	Symbol	R/W	Description	Default
7:6	Reserved	RW	Not used	00
5:4	Reserved	RW	Reserved	00
3:0	BST_IPEAK	RW	BOOST peak current limit	1000
			0010: 2A	
			0011: 2.25A	
			0100: 2.5A	

			0101: 2.75A	
			0110: 3A	
			0111: 3.25A	
			1000: 3.5A	
			1001: 3.75A	
			1010: 4A	
			1011: 4.25A	
			1100: 4.5A	

**CLASS D GAIN CONTROL REGISTER (ADDRESS: 0x06)**

Bit	Symbol	R/W	Description	Default
7:5	Reserved	RW	Not used	000
4:0	PA_GAIN	RW	PA Input Signal Gain when RCV_MODE=1, PA_GAIN must be set to 0000~00111 when RCV_MODE=0, PA_GAIN must be set to 01000~10010 00000:0dB 00001: 1.5dB 00010: 3dB 00011: 4.5dB 00100: 6dB 00101: 7.5dB 00110: 9dB 00111: 10.5dB 01000: 12dB 01001: 13.5dB 01010: 15dB 01011: 16.5dB 01100: 18dB 01101: 19.5dB 01110: 21dB 01111: 22.5dB 10000: 24dB 10001: 25.5dB 10010: 27dB	10000

**CLASS D AGC3 OUTPUT POWER (AGC3\_Po) REGISTER (ADDRESS: 0x07)**

Bit	Symbol	R/W	Description	Default
7:5	Reserved	RW	Reserved	100
4	PD_AGC3	RW	Disable AGC3 0: Enable 1: Disable	0
3:0	AGC3_OUTPUT_POWER	RW	Speaker Protection output Power Level 0000: 0.5W @8 ohm      0000: 0.67W @6 ohm 0001: 0.6W @8 ohm      0001: 0.8W @6 ohm 0010: 0.7W @8 ohm      0010: 0.93W @6 ohm 0011: 0.8W @8 ohm      0011: 1.07W @6 ohm 0100: 0.9W @8 ohm      0100: 1.20W @6 ohm 0101: 1.0W @8 ohm      0101: 1.33W @6 ohm 0110: 1.1W @8 ohm      0110: 1.47W @6 ohm 0111: 1.2W @8 ohm      0111: 1.6W @6 ohm 1000: 1.3W @8 ohm      1000: 1.73W @6 ohm 1001: 1.4W @8 ohm      1001: 1.87W @6 ohm 1010: 1.5W @8 ohm      1010: 2.0W @6 ohm 1011: 1.6W @8 ohm      1011: 2.13W @6 ohm	0011

			1100: 1.7W @8 ohm	1100: 2.27W @6 ohm	
			1101: 1.8W @8 ohm	1101: 2.4W @6 ohm	
			1110: 1.9W @8 ohm	1110: 2.53W @6 ohm	
			1111: 2.0W @8 ohm	1111: 2.67W @6 ohm	

**CLASS D AGC3 PARAMETER (AGC3) REGISTER (ADDRESS: 0x08)**

Bit	Symbol	R/W	Description	Default
7:5	AGC3_REL_TIME	RW	Total 13.5dB release time.	010
			000: 5.12ms/dB	
			001: 10.24ms/dB	
			010: 20.48ms/dB	
			011: 40.96ms/dB	
			100: 81.92ms/dB	
			101: 163.84ms/dB	
			110: 327.68ms/dB	
			111: 655.36ms/dB	
4:2	AGC3_ATT_TIME	RW	Total 13.5dB attack time.	011
			000: 1.28ms/dB	
			001: 2.56ms/dB	
			010: 10.24ms/dB	
			011: 40.96ms/dB	
			100: 82ms/dB	
			101: 164ms/dB	
			110: 328ms/dB	
111: 656ms/dB				
1:0	Reserved	RW	Not used	10

**CLASS D AGC2 OUTPUT POWER (AGC2\_Po) REGISTER (ADDRESS: 0x09)**

Bit	Symbol	R/W	Description	Default	
7:4	Reserved	RW	Not used	0000	
3:0	AGC2_OUTPUT_POWER	RW	AGC2 output Power Level.	0011	
			0000: 1.0W @8 ohm		0000: 1.33W @6 ohm
			0001: 1.2W @8 ohm		0001: 1.60W @6 ohm
			0010: 1.4W @8 ohm		0010: 1.87W @6 ohm
			0011: 1.6W @8 ohm		0011: 2.13W @6 ohm
			0100: 1.8W @8 ohm		0100: 2.4W @6 ohm
			0101: 2.0W @8 ohm		0101: 2.67W @6 ohm
			0110: 2.2W @8 ohm		0110: 2.93W @6 ohm
			0111: 2.4W @8 ohm		0111: 3.2W @6 ohm
			1000: 2.6W @8 ohm		1000: 3.47W @6 ohm
			1001: 2.8W @8 ohm		1001: 3.73W @6 ohm
			1010: 3.0W @8 ohm		1010: 4.0W @6 ohm
			1011: AGC2 OFF		1011: AGC2 OFF

**CLASS D AGC2 PARAMETER (AGC2) REGISTER (ADDRESS: 0x0A)**

Bit	Symbol	R/W	Description	Default
7:5	Reserved	RW	Not used	000
4:2	AGC2_ATT_TIME	RW	AGC2 total attack time.	010
			000: 0.16ms/dB	
			001: 0.32ms/dB	
			010: 0.64ms/dB	
			011: 2.56ms/dB	
			100: 10.24ms/dB	
			101: 40.96ms/dB	
			110: 82ms/dB	
111: 164ms/dB				

1:0	Reserved	RW	Not used	00
-----	----------	----	----------	----

**CLASS D AGC1 PARAMETER (AGC1) REGISTER (ADDRESS: 0x0B)**

Bit	Symbol	R/W	Description	Default
7:3	Reserved	RW	Not used	01001
2:1	AGC1_ATT_TIME	RW	Fastest Level AGC attack time control	01
			When AGC1_ATT_TIMEA=0	
			00: 0.04ms/dB	
			01: 0.08ms/dB	
			10: 0.16ms/dB	
			11: 0.32ms/dB	
			When AGC1_ATT_TIMEA=1	
			00: 0.02ms/dB	
0	PD_AGC1	RW	Disable fastest level AGC,	0
			0: Enable	
			1: Disable	

**ADP MODE PARAMETER REGISTER (ADDRESS: 0x0C)**

Bit	Symbol	R/W	Description	Default
7:4	Reserved	RW	Not used	0000
3	AGC1_ATT_TIMEA	RW	Fastest Level AGC attack time control, Refer to 0x0B register	0
2:0	ADPBOOST_MODE	RW	BOOST MODE	011
			000: Pass Through	
			001: Force BOOST	
			010: ADP BOOST MD1	
			011: ADP BOOST MD2	
	100~111: Reserved and Unused			

**ADP BOOST PARAMETER REGISTER (ADDRESS: 0x0D)**

Bit	Symbol	R/W	Description	Default
7:4	ADP_BST_TIME2	RW	Duration time Po less than Po2	0111
			0000~0100: Reserved and Unused	
			0101: 20ms	
			0110: 30ms	
			0111: 40ms	
			1000: 65ms	
			1001: 80ms	
			1010: 100ms	
			1011: 120ms	
			1100: 140ms	
			1101: 160ms	
			1110: 320ms	
			1111: 480ms	
3:0	ADP_BST_TIME1	RW	Duration time Po less than Po1	0111
			0000~0100: Reserved and Unused	
			0101: 20ms	
			0110: 30ms	
			0111: 40ms	
			1000: 65ms	
			1001: 80ms	
			1010: 100ms	
			1011: 120ms	

		1100: 140ms
		1101: 160ms
		1110: 320ms
		1111: 480ms

**ADP BOOST PARAMETER REGISTER (ADDRESS: 0x0E)**

Bit	Symbol	R/W	Description	Default
7:0	Reserved	RW	Not used	01111010

**ADP BOOST PARAMETER REGISTER REGISTER (ADDRESS: 0x0F)**

Bit	Symbol	R/W	Description	Default
7:6	ADP_LOW_STEP	RW	ADP BOOST mode2 first step set BOOST_OUT<4:0>	01
			00: 1st BST_OUT=6.5V	
			01: 1st BST_OUT=6.75V	
			10: 1st BST_OUT=7.0V	
			11: 1st BST_OUT=7.25V	
5:3	SET_BOOST_VTH2	RW	Boost threshold Po2	010
			000: 1.2W	
			001: 1.4W	
			010: 1.6W	
			011: 1.8W	
			100: 2.0W	
			101: 2.2W	
110~111: Reserved and Unused				
2:0	SET_BOOST_VTH1	RW	Boost threshold Po1	001
			000: 0.1W	
			001: 0.2W	
			010: 0.3W	
			011: 0.4W	
			100~111: Reserved and Unused	

## APPLICATION INFORMATION

### EXTERNAL COMPONENTS

#### BOOST INDUCTOR SELECTION

Selecting inductor needs to consider Inductance, size, magnetic shielding, saturation current and temperature current.

##### a) Inductance

Inductance value is limited by the boost converter's internal loop compensation. In order to ensure phase margin sufficient under all operating conditions, recommended 1μH inductor.

##### b) Size

For a certain value of inductor, the smaller the size, the greater the parasitic series resistance of the inductor DCR, the higher the loss, corresponds to the lower efficiency.

##### c) Magnetic shielding

Magnetic shielding can effectively prevent the inductance of the electromagnetic radiation interference. It is much better to choose inductance with magnetic shielding in the application of EMI sensitive environment.

##### d) Saturation current and temperature rise of current

Inductor saturation current and temperature rise current value are important basis for selecting the inductor. As the inductor current increases, on the one hand, since the magnetic core begins to saturate, inductance value will decline; on the other hand, the inductor's parasitic resistance inductance and magnetic core loss can lead to temperature rise. In general, the current value is defined as the saturation current  $I_{SAT}$  when the inductance value drops to 70%; the current value is defined as temperature rise current  $I_{RMS}$  when inductance temperature rise 40°C.

For particular applications, need to calculate the maximum  $I_{L\_PEAK}$  and  $I_{L\_RMS}$ , which is a basis of selecting the inductor. When  $V_{DD} = 4.2V$ ,  $V_{BST}=9V$ ,  $R_L = 8\Omega$ , amplifier  $R_{DSON} = 250m\Omega$ , when  $THD = 1\%$  (the maximum power without distortion), the output power is calculated as follows:

$$P_{OUT} = \frac{\left( V_{OUT} \times \frac{R_L}{R_L + R_{DSON}} \right)^2}{2 \times R_L} = \frac{\left( 9 \times \frac{8}{8 + 0.25} \right)^2}{2 \times 8} = 4.75W$$

In such a large output power, the overall efficiency of the power amplifier is typically 80%, in order to calculate the maximum average current  $I_{MAX\_AVG\_VDD}$  and maximum peak current  $I_{MAX\_PEAK\_VDD}$  drawn from VDD:

$$I_{MAX\_AVG\_VDD} = \frac{P_{OUT}}{V_{DD} \times \eta} = \frac{4.75}{4.2 \times 0.8} A = 1.41A$$

$$I_{MAX\_PEAK\_VDD} = 2 \times I_{MAX\_AVG\_VDD} = 2.82A$$

If inductor DCR is 50mΩ, the inductor power loss at this time is:

$$P_{DCR,LOSS} = 1.5 \cdot I_{MAX\_AVG\_VDD}^2 \cdot DCR = 1.5 \times 1.41^2 \times 0.05W = 149mW$$

Wherein the coefficient 1.5 is the square of the ratio of the sine wave current RMS value and average value (there is no consideration of the impact of the inductor ripple, the actual DCR loss will be even greater). If the loss which is resulting from DCR is less than 1% at maximum efficiency ( $P_{OUT} = 2.5W$ ,  $\eta = 80\%$ ), then:

$$I_{AVG\_VDD} = \frac{P_{OUT}}{V_{DD} \times \eta} = \frac{2.5}{4.2 \times 0.8} = 0.74A$$

$$DCR = \frac{P_{DCR,LOSS}}{1.5 \cdot I_{AVG\_VDD}^2} \leq 0.01 \times \frac{P_{OUT}}{1.5 \cdot I_{AVG\_VDD}^2 \cdot \eta} = \frac{0.01 \times 2.5}{1.5 \times 0.74^2 \times 0.8} \Omega = 38m\Omega$$

According to the working principle of the Boost, we can calculate the size of the inductor current ripple  $\Delta I_L$ :

$$\Delta I_L = \frac{V_{DD} \times (V_{OUT} - V_{DD})}{V_{OUT} \times f \times L} = \frac{4.2 \times (9 - 4.2)}{9 \times 1.6 \times 10^6 \times 1 \times 10^{-6}} A = 1.4A$$

Thus, the maximum peak inductor current  $I_{L\_PEAK}$  and maximum effective inductor current  $I_{L\_RMS}$  is:

$$I_{L\_PEAK} = I_{MAX\_PEAK\_VDD} + \frac{\Delta I_L}{2} = 2.82A + \frac{1.4}{2} A = 3.52A$$

$$I_{L\_RMS} = \sqrt{I_{MAX\_PEAK\_VDD}^2 + \frac{\Delta I_L^2}{12}} = \sqrt{2.82^2 + \frac{1.4^2}{12}} A = 2.85A$$

From the above calculation results:

- 1) For typical DCR about 38mΩ inductance, the efficiency loss caused by around 1.5%;
- 2) In practice, the maximum output power of the amplifier is likely to reach 4.75W in an instant, so the selected inductor saturation current  $I_{SAT}$  requires more than the maximum inductor peak current  $I_{L\_PEAK}$ ;
- 3) In some cases, if the  $I_{L\_PEAK}$  calculated according to the above method is greater than the set of input inductor current limit value  $I_{LIMIT}$ , shows the power amplifier is restricted by inductance input current limit, the actual maximum output power is less than the calculated value, the measured value shall prevail, and  $I_{SAT}$  need greater than the set current limiting value  $I_{LIMIT}$ , and cannot be less than 2.82A;
- 4) For example, under different conditions, the typical method of selecting  $I_{SAT}$  in the following table:

VDD(V)	VBST(V)	RL(Ω)	ILIMIT(A)	Efficiency(η) (%)	PO(W)	IL_PEAK(A)	Inductor saturation current ISAT minimum value (A)
4.2	9.0	8	4	80	4.75	3.52	4.0
4.2	9.0	6	4	75	5.55	4.2	4.5

- 5) As the result of the action of AGC, amplifier will not work long hours at maximum power without distortion, the actual average inductor current is far less than the maximum inductor current effective  $I_{L\_RMS}$ , so when selecting the inductor, the inductor temperature rise current is not usually a limiting factor;
- 6) Inductor Selection example: the inductor package size is 252012, inductance value is 1μH, DCR Typical value is 47mΩ, the typical saturation current  $I_{SAT}$  is 4.2A, the typical temperature rise current  $I_{RMS}$  is 3.0A, suitable for VDD=3.6V, VBST=9.0V, speaker impedance  $R_L=8\Omega$ , inductor input current limit  $I_{LIMIT}=4.2A$ . If you choose  $I_{SAT}$  or  $I_{RMS}$  of the inductance is too small, it is possible to cause the chip don't work properly, or the temperature of the inductance is too high.

Inductance value	size	DCR ( Ω )	ISAT ( A )	IRMS ( A )
1uH	2.5x2.0x1.2mm	0.047	4.2	3.0

## CAPACITOR SELECTION

### BOOST CAPACITOR SELECTION

The output capacitor of chargepump is usually within the range  $0.1\mu\text{F}$ – $47\mu\text{F}$ , It needs to use Class II type (EIA) multilayer ceramic capacitors (MLCC). Its internal dielectric is ferroelectric material (typically  $\text{BaTiO}_3$ ), a high the dielectric constant in order to achieve smaller size, but at the same Class II type (EIA) multilayer ceramic capacitors has poor temperature stability and voltage stability as compared to the Class I type (EIA) capacitance. Capacitor is selected based on the requirements of temperature stability and voltage stability, considering the capacitance material, capacitor voltage, and capacitor size and capacitance values.

#### a) temperature stability

Class II capacitance have different temperature stability in different materials, usually choose X5R type in order to ensure enough temperature stability, and X7R type capacitance has better properties, the price is relatively more expensive. X5R capacitance change within  $\pm 15\%$  in temperature range of  $55^\circ\text{C}$  to  $85^\circ\text{C}$ , X7R capacitance change within  $\pm 15\%$  in temperature range of  $-55^\circ\text{C}$ – $125^\circ\text{C}$ . The output capacitance of the AW87559's chargepump recommends X5R ceramic capacitors.

#### b) Voltage Stability

Class II type capacitor has poor voltage stability ——Capacitance values falling fast along with the DC bias voltage applied across the capacitor increasing. The rate of decline is related to capacitance material, capacitors rated voltage, capacitance volume. Take for TDK C series X5R for example, its pressure voltage value is 16V or 25V, the package size is 0805, 1206 or 0603, the capacitance value is  $10\mu\text{F}$ . The capacitor's voltage stability of different types of capacitor is as shown below:

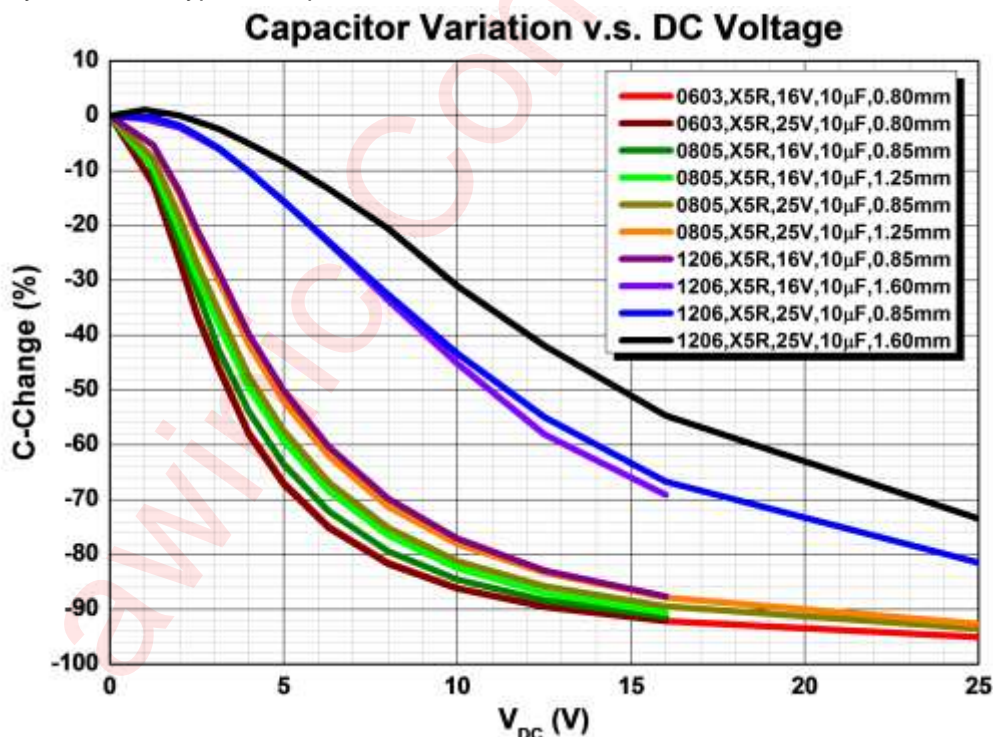

**Figure 24 Different Types of Capacitive Voltage Stability**

It can be found that the rate of capacitance capacity value descent becomes slow along with "large capacitor size, capacitance pressure voltage rise". The larger the package size, the better voltage stability. The higher the height, the better voltage stability with the same length and width of the capacitance. Voltage stability of smaller package size (0603) capacitor change affected by the pressure value is very small.

In AW87559 typical applications, it is necessary to ensure the output value of the VBST capacitor  $\geq 3.6\mu\text{F}$  when  $\text{VBST}=9.0\text{V}$ .

Take the following capacitances as the Boost of the output capacitor for example:

value	material	size (mm <sup>3</sup> )	rated voltage (V)	quantity	value@9.0V
10uF	X5R	1.60×0.80×0.80 (0603)	16	3	5.4uF
10uF	X5R	2.00×1.25×1.25 (0805)	25	2	5.4uF

As for the different manufacturers' capacitors, it's important to determine the type and quantity of the capacitors through the capacitor voltage stability data provided by the manufacturer.

### INPUT CAPACITOR- $C_{in}$ (INPUT HIGH-PASS CUTOFF FREQUENCY)

The input capacitors and input resistors form a high-pass filter to filter out the DC component of the input signal. The -3dB frequency points of the high pass filter is shown below:

$$f_H(-3\text{dB}) = \frac{1}{2\pi \times R_{\text{intotal}} \times C_{\text{in}}} \text{ (Hz)}$$

The selection of a smaller  $C_{in}$  capacitor in the application helps to filter out 217Hz noise, which comes from the input coupling, and the smaller capacitor is advantageous to reduce the pop-click noise when the power amplifier turn on. Better matching of the input capacitors improves performance of the circuit and also helps to suppress pop-click noise. A capacitor value deviation of 10% or better capacitance is recommended.

Take typical application as an example, the input high-pass cutoff frequency is calculated as below:

$$f_H(-3\text{dB}) = \frac{1}{2\pi \times R_{\text{intotal}} \times C_{\text{in}}} = \frac{1}{2\pi \times 9\text{k}\Omega \times 68\text{nF}} \text{ (Hz)} = 260\text{Hz}$$

Class D-type speaker & receiver 2-in-1 application (Gain=9dB), the input high pass frequency is as follows:

$$f_H(-3\text{dB}) = \frac{1}{2\pi \times R_{\text{intotal}} \times C_{\text{in}}} = \frac{1}{2\pi \times 38\text{k}\Omega \times 68\text{nF}} \text{ (Hz)} = 62\text{Hz}$$

### SUPPLY DECOUPLING CAPACITOR ( $C_s$ )

A good decoupling capacitor can improve the efficiency and the best performance of the power amplifier. At the same time, in order to get good high frequency transient performance, the ESR value of the capacitor should be as small as possible. In AW87559 applications, low ESR (equivalent-series-resistance) X7R or X5R ceramic capacitors are recommended. Generally, 10 $\mu\text{F}$  ceramic capacitors are used to bypass the VDD to the ground, and the decoupling capacitor should be placed as close to the VDD chip as possible in the layout. If you want to filter out low-frequency noise better, you need to add a 10 $\mu\text{F}$  or greater decoupling capacitor depending on your application. Meanwhile, a 33pF~0.1 $\mu\text{F}$  ceramic capacitor is placed on the pin of the power supply to filter the high frequency interference on the power supply. The capacitor should be placed as close as possible to the pin3 and inductor.

### OUTPUT BEADS, CAPACITORS, TVS

Using EEE technology, in the class K mode, the AW87559 can also meet the FCC CLASS B specification requirements. It is recommended to Use ferrite chip beads and capacitors if device near the EMI sensitive circuits, there are long leads from amplifier to speaker, placed as close as possible to the output pin.

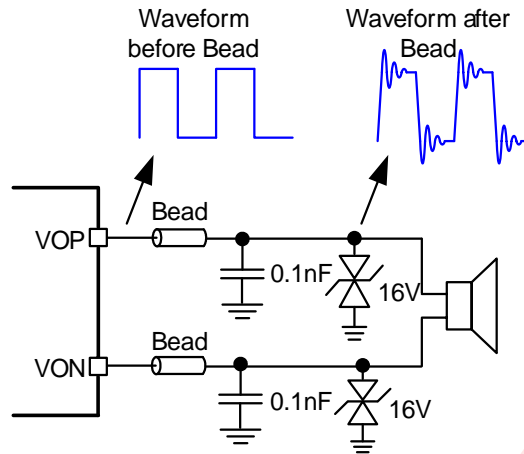

**Figure 25 Ferrite Chip Bead and Capacitor**

Amplifier output is a square wave signal. The voltage across the capacitor will be much larger than the VBST voltage after increasing the bead capacitor. It suggested the use of rated voltage above 16V capacitor. At the same time a square wave signal at the output capacitor switching current form, the static power consumption increases, so the output capacitance should not be too much which is recommended 0.1nF ceramic capacitor rated voltage of 16V. If you want to get better EMI suppression performance, can use 1nF, rated voltage 16V capacitor, but quiescent current will increase.

Power amplifier output PWM signals of high voltage to VBST voltage, voltage to 9.0 V, will produce some ringing after bead capacitor, resulting in higher peak voltage. Recommended choose the operating voltage of 16V TVS.

## PCB AND DEVICE LAYOUT CONSIDERATION

### EXTERNAL COMPONENTS PLACEMENT

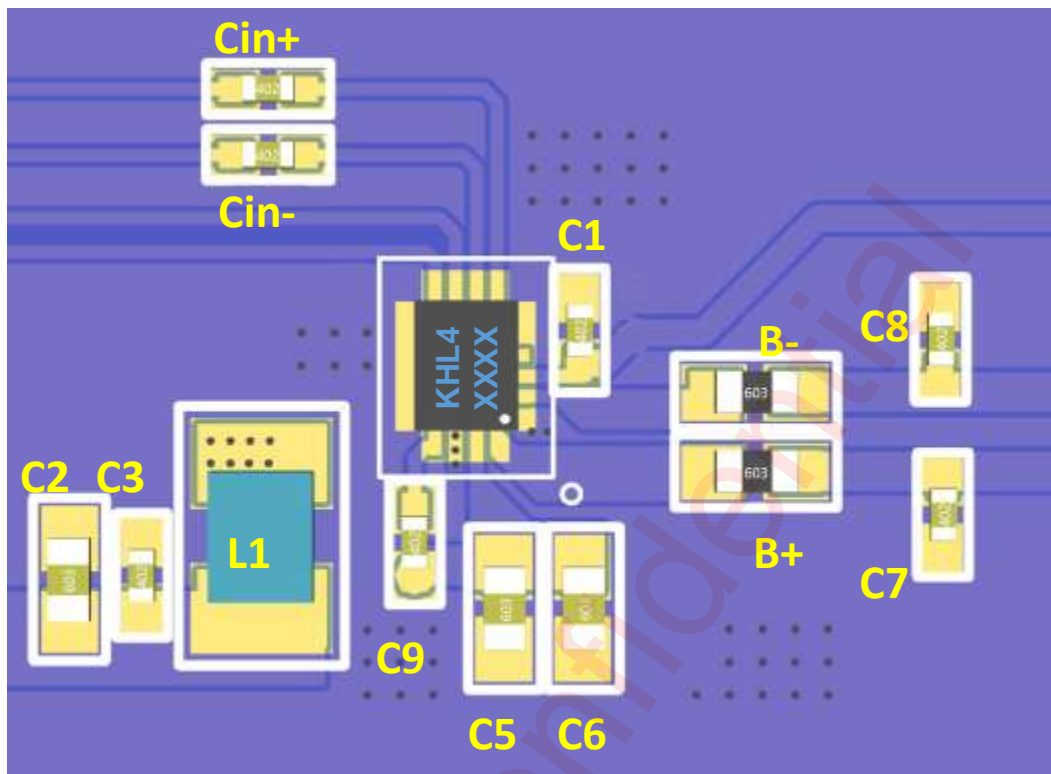

Figure 26 AW87559 External Components Placement

### LAYOUT CONSIDERATIONS

This device is a power amplifier chip. To obtain the optimal performance, PCB layout should be considered carefully.

In order to obtain excellent performance of AW87559, PCB layout must be carefully considered. The design consideration should follow the following principles:

1. In AW87559 peripheral device layout, you first need to guarantee the chargepump output capacitance close to VBST pin.
2. All the filter capacitors of the audio PA (including CVDD, CVBST and CVREG) should be placed close to the pins of the chip.
3. Please place the VREG capacitor close to the VBST capacitor. The parasitic inductance of the CVREG capacitor should be less than 3nH. Minimize inductance as much as possible.
4. Traces of SW pin should support currents up to device over-current limit (peak current 3.5A). VDD and SW traces are separated.
5. Try to provide a separate short and thick power line to AW87559, the copper width is recommended to be larger than 0.75mm. The decoupling capacitors should be placed as close as possible to boost power supply pin.
6. The input capacitors should be close to AW87559 INN and INP input pin, the input line should be parallel to suppress noise coupling.
7. The beads and capacitor should be placed near to AW87559 VON and VOP pin. The output line from AW87559 to speaker should be as short and thick as possible. The width is recommended to be larger than 0.5mm.

## TAPE & REEL DESCRIPTION

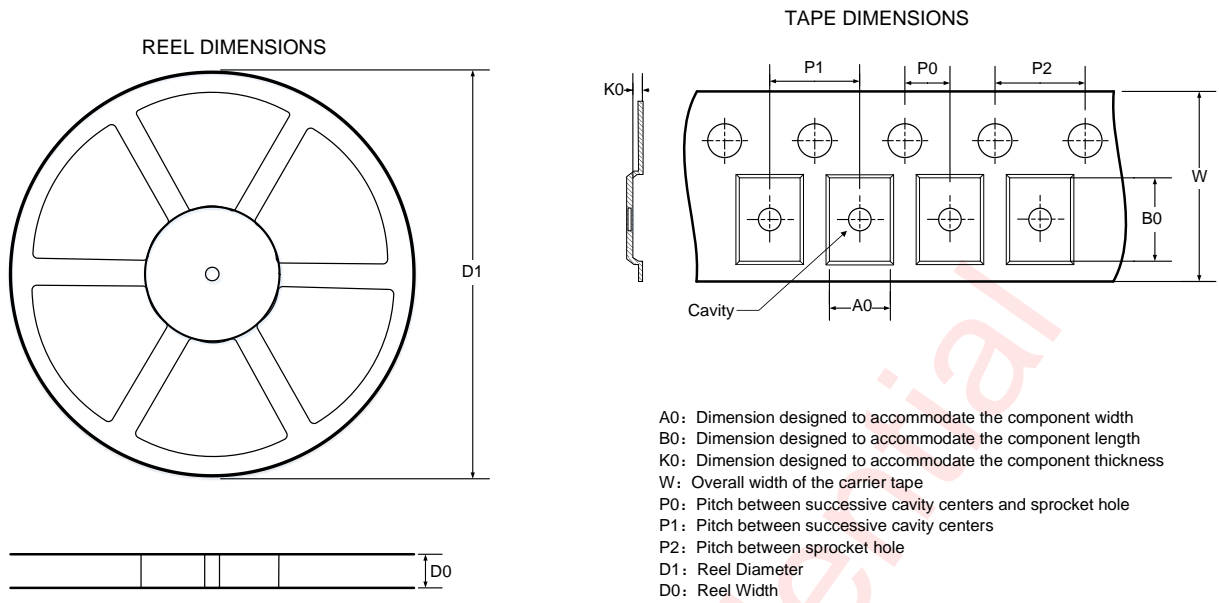

### QUADRANT ASSIGNMENTS FOR PIN 1 ORIENTATION IN TAPE

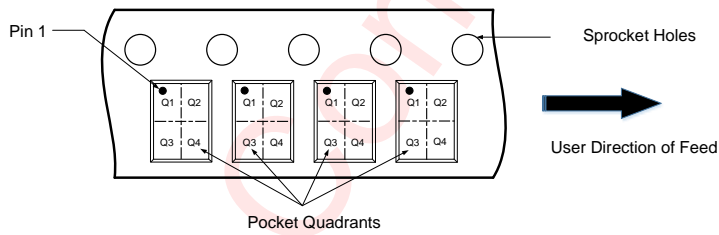

All Dimensions are nominal

D1 (mm)	D0 (mm)	A0 (mm)	B0 (mm)	K0 (mm)	P0 (mm)	P1 (mm)	P2 (mm)	W (mm)	Pin1 Quadrant
330	12.4	2.3	3.3	0.75	2	4	4	12	Q1

PACKAGE DESCRIPTION

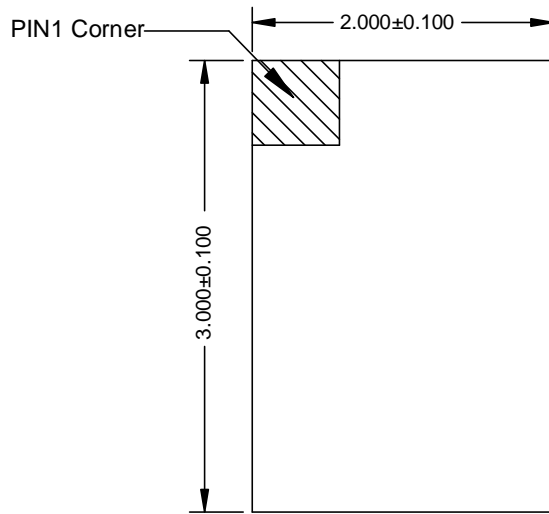

TOP VIEW

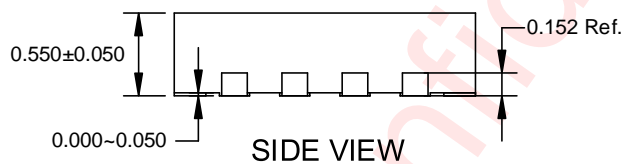

SIDE VIEW

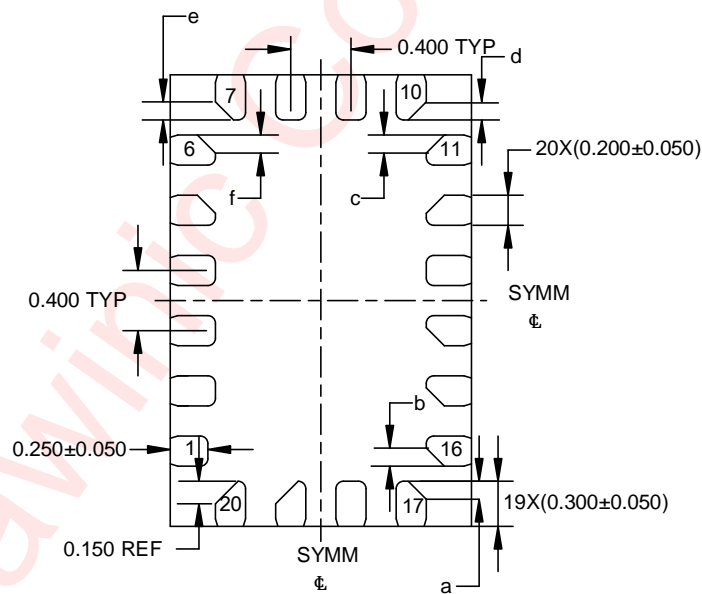

Note: a=b=c=d=e=f=0.120mm

BOTTOM VIEW

Unit : mm

LAND PATTERN

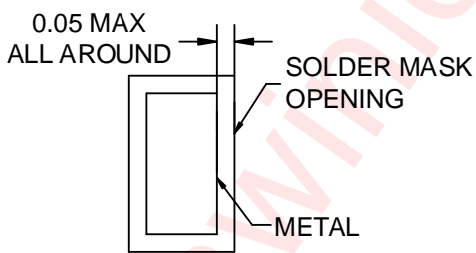
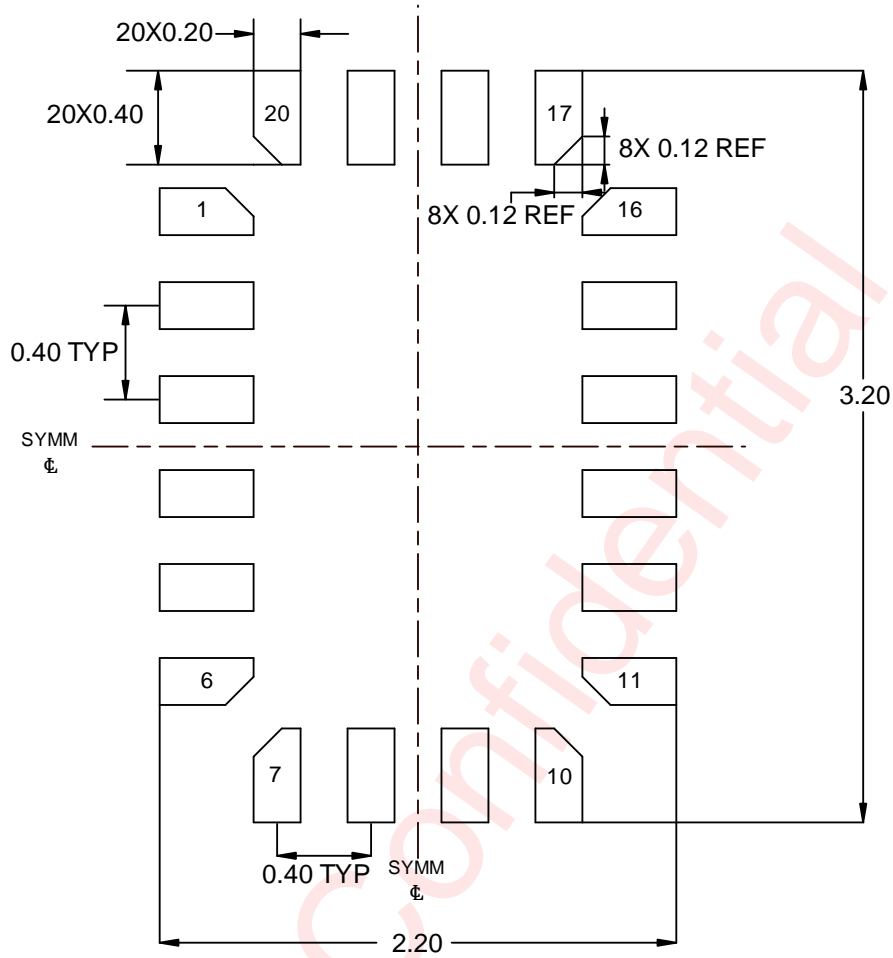

NON-SOLDER MASK DEFINED

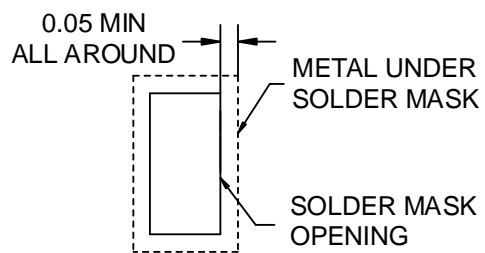

SOLDER MASK DEFINED

Unit : mm

## VERSION INFORMATION

Version	Date	Description
V1.0	2020-06-06	AW87559FCR datasheet V1.0
V1.1	2020-07-06	<ol style="list-style-type: none"><li>1. Modify PVDD voltage to VBST</li><li>2. Modify EXPVDD mode to EX-VBST mode</li><li>3. Modify CLASSD GAIN CONTROL REGISTER(0x06) Description</li><li>4. Modify Electrical characteristics of RCV 1% THD Po</li></ol>
V1.2	2021-03-31	<ol style="list-style-type: none"><li>1. Modify “The master device transmits 8 bits of data to register which needs to be read” to “The slave device transmits 8 bits of data to register which needs to be read”</li><li>2. Modify ADP register name</li><li>3. Modify VBST capacitor <math>\geq 4\mu\text{F}</math> to capacitor <math>\geq 3.6\mu\text{F}</math></li></ol>

## DISCLAIMER

Information in this document is believed to be accurate and reliable. However, Shanghai AWINIC Technology Co., Ltd (AWINIC Technology) does not give any representations or warranties, expressed or implied, as to the accuracy or completeness of such information and shall have no liability for the consequences of use of such information.

AWINIC Technology reserves the right to make changes to information published in this document, including without limitation specifications and product descriptions, at any time and without notice. Customers shall obtain the latest relevant information before placing orders and shall verify that such information is current and complete. This document supersedes and replaces all information supplied prior to the publication hereof.

AWINIC Technology products are not designed, authorized or warranted to be suitable for use in medical, military, aircraft, space or life support equipment, nor in applications where failure or malfunction of an AWINIC Technology product can reasonably be expected to result in personal injury, death or severe property or environmental damage. AWINIC Technology accepts no liability for inclusion and/or use of AWINIC Technology products in such equipment or applications and therefore such inclusion and/or use is at the customer's own risk.

Applications that are described herein for any of these products are for illustrative purposes only. AWINIC Technology makes no representation or warranty that such applications will be suitable for the specified use without further testing or modification.

All products are sold subject to the general terms and conditions of commercial sale supplied at the time of order acknowledgement.

Nothing in this document may be interpreted or construed as an offer to sell products that is open for acceptance or the grant, conveyance or implication of any license under any copyrights, patents or other industrial or intellectual property rights.

Reproduction of AWINIC information in AWINIC data books or data sheets is permissible only if reproduction is without alteration and is accompanied by all associated warranties, conditions, limitations, and notices. AWINIC is not responsible or liable for such altered documentation. Information of third parties may be subject to additional restrictions.

Resale of AWINIC components or services with statements different from or beyond the parameters stated by AWINIC for that component or service voids all express and any implied warranties for the associated AWINIC component or service and is an unfair and deceptive business practice. AWINIC is not responsible or liable for any such statements.